

5 Port Solenoid Valve

Series *SV1000/2000/3000/4000*

Rubber Seal

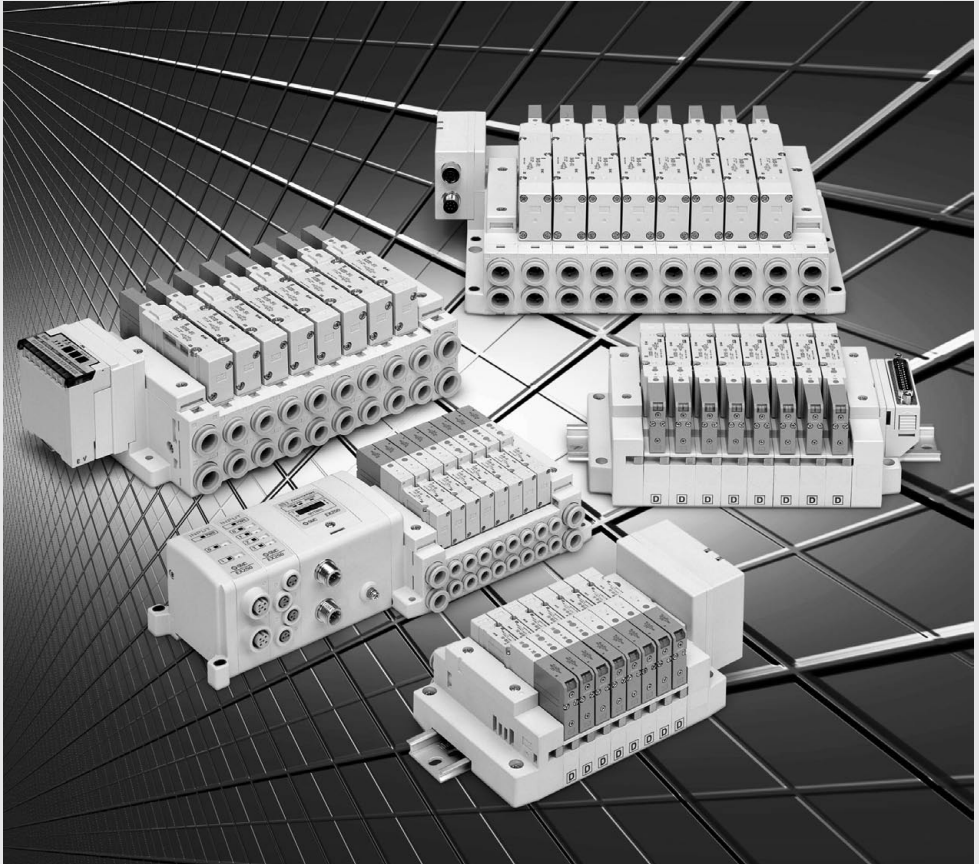

Connector Type Manifold

- SJ
- SY
- SY
- SV
- SYJ
- SZ
- VF
- VP4
- S0700
- VQ
- VQ4
- VQ5
- VQC
- VQC4
- VQZ
- SQ
- VFS
- VFR
- VQ7

Connector Type Manifold

Series SV1000/2000/3000/4000

- The use of multi-pin connectors to replace wiring inside manifold blocks provides flexibility when adding stations or changing manifold configuration.

Series SV employs a multi-connector instead of the conventional lead wires for internal. By connecting each block with a connector, changes to manifold stations are greatly simplified.

Connector wiring diagram

For both serial and parallel wiring, additional manifold blocks are sequentially assigned pins on the connector. This makes it completely unnecessary to disassemble the connector unit.

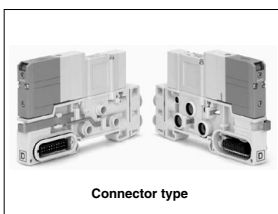
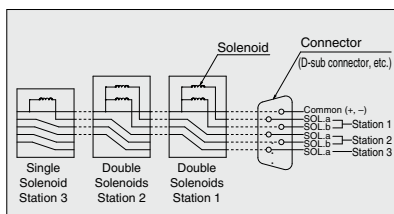

Service life of 50 million cycles or more
(Based on SMC life test conditions)

■ Cassette base type manifold (For SV1000/2000)

Cassette base type manifolds offer the ultimate in flexibility. Manifold sections can be added using a simple release mechanism.

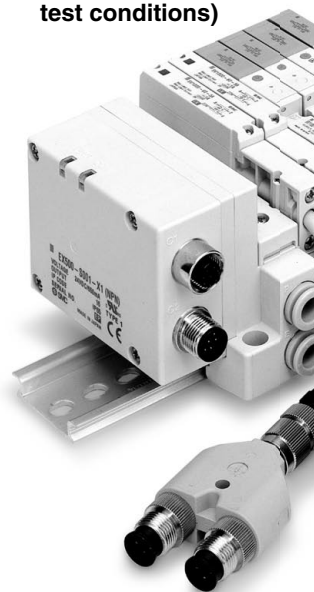
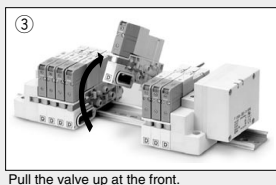
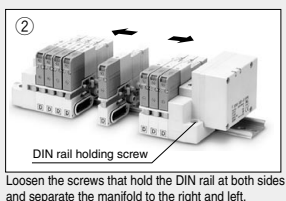
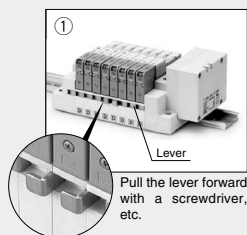

Power consumption: 0.6 W
(Current: 25 mA, 24 VDC)

■ Tie-rod base manifold (For SV1000/2000/3000/4000)

Conventional tie-rod base type manifolds are also available. 34 pins connector allows up to 16 stations with double solenoids. (Refer to the tie-rod base manifold exploded view on page 626.)

- A relay output module control of devices up to 110 VAC, 3 A.

■ The standard product is CE-compliant and UL-standard.

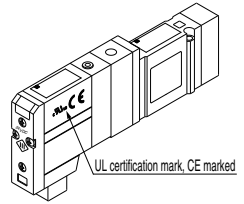

■ Series EX500: Gateway-type, serial transmission system

- IP67 compliant (Gateway unit and input manifold are compliant with IP65.)
- No. of input/output point: 128 points (Output 64 points, Input 64 points)
- Controls up to 4 branches with 32 I/O per branch
- A single cable from the gateway provides both signal and power for each branch, eliminating the need for separate power connections for each manifold.

■ Series EX250: Integrated-type (for I/O), serial transmission system

- IP67 compliant (compliant with IP40.)
- No. of input/output point: 64 points (Output 32 points, Input 32 points)
- Double solenoid allows up to 16 stations (up to 32 solenoids).

■ Interface regulator Series SV1000, 2000, 3000, 4000

- P port regulation, A port regulation and B port regulation are selectable, depending on an application. Able to set the pressure arbitrarily for each station of the manifold just by inserting between manifold base and valve.



■ Increased moisture and dust resistance.

- Enclosure against foreign matters and water is conforming to IP67*. Can be used in an atmosphere where the valve or manifold is exposed by water, etc. directly. (* Based on IEC60529) (Refer to the catalog contents for details, as some types of connectors do not meet these standards.)

■ 4 position dual 3 port valves available for Series SV1000/2000

- Two 3 port valves built into a single valve body.
- A and B ports can be individually controlled.
- Three combinations are available: [N.C./N.C.], [N.O./N.O.], and [N.C./N.O.].
- Mixed mounting with 5 port valves is also possible.
- Labels are attached to indicate A and B side functions, using the same color as the manual override.

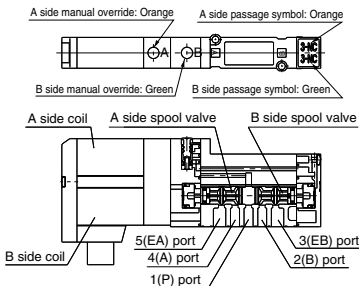

Model	A side	B side	Symbol	
			Series SV1000	Series SV2000
SV1A00	N.C. valve	N.C. valve		
SV1B00	N.O. valve	N.O. valve		
SV1C00	N.C. valve	N.O. valve		

* External pilot specifications is not available for 4 position dual 3 port valves.

- SJ
- SY
- SY
- SV
- SYJ
- SZ
- VF
- VP4
- S0700
- VQ
- VQ4
- VQ5
- VQC
- VQC4
- VQZ
- SQ
- VFS
- VFR
- VQ7

INDEX

Series SV Manifold Variations

Serial Wiring

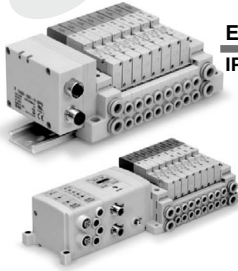

Valve Manifold Common Specifications P. 532

Manifold specifications

EX500 Gateway-type Serial Transmission System P. 535

IP67 compliant

Applicable series **Cassette base manifold**
SV1000/SV2000

Applicable series **Tie-rod base manifold**
SV1000/SV2000/SV3000/SV4000

- Number of output points: 16 points
- Connected to the EX500GW unit

EX250 Integrated-type (For I/O) Serial Transmission System P. 545

IP67 (partly IP40) compliant

Applicable series **Tie-rod base manifold**
SV1000/SV2000/SV3000

- Number of input/output points: Each 32 points

EX600 Integrated-type (For I/O) Serial Transmission System P. 551

IP67 compliant

Applicable series **Tie-rod base manifold**
SV1000/SV2000/SV3000

- Digital input/output: Max. 144 inputs/144 outputs
- Analog input: Max. 18 channels
- Valve output: 32 outputs

EX260 Integrated-type (For Output) Serial Transmission System P. 561

IP67 (partly IP40) compliant

Applicable series **Tie-rod base manifold**
SV1000/SV2000/SV3000

- Number of output points: 16 points

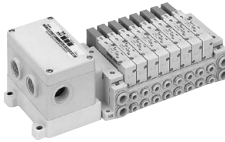

EX126 Integrated-type (For Output) Serial Transmission System P. 567

IP67 compliant

Applicable series **Tie-rod base manifold**
SV1000/SV2000/SV3000

- Number of output points: 16, 32 points

EX120 Integrated-type (For Output) Serial Transmission System P. 573

Applicable series **Cassette base manifold**
SV1000/SV2000

Applicable series **Tie-rod base manifold**
SV1000/SV2000/SV3000/SV4000

- Number of output points: 16 points

Parallel Wiring

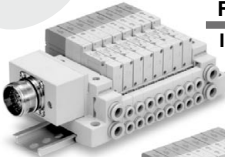

For Circular Connector

IP67 compliant

Applicable series **Cassette base manifold**
SV1000/SV2000

Applicable series **Tie-rod base manifold**
SV1000/SV2000/SV3000/SV4000

- Number of connectors: 26 pins

D-sub Connector

Applicable series **Cassette base manifold**
SV1000/SV2000

Applicable series **Tie-rod base manifold**
SV1000/SV2000/SV3000/SV4000

- Number of connectors: 25 pins
- MIL-C-24308 Conforming to JIS-X-5101

Flat Ribbon Cable Connector P. 603

Applicable series **Cassette base manifold**
SV1000/SV2000

Applicable series **Tie-rod base manifold**
SV1000/SV2000/SV3000/SV4000

- Number of connectors: 26, 20, 10 pins
- With strain relief Conforming to MIL-C-83503

Flat Ribbon Cable PC Wiring P. 606

Applicable series **Cassette base manifold**
SV1000/SV2000

Applicable series **Tie-rod base manifold**
SV1000/SV2000/SV3000/SV4000

- Number of connectors: 20 pins
- Conforming to MIL-C-83503

Manifold Exploded View/Manifold Options P. 622

Single Valve/Sub-plate [IP67 compliant] P. 638

IP67 compliant

Applicable series **SV1000/SV2000/SV3000/SV4000**

- With waterproof M12 connector

Made to Order Specifications P. 646



SJ
SY
SY
SV
SYJ
SZ
VF
VP4
S0700
VQ
VQ4
VQ5
VQC
VQC4
VQZ
SQ
VFS
VFR
VQ7

Valve Manifold Common Specifications Series SV



Cassette base manifold

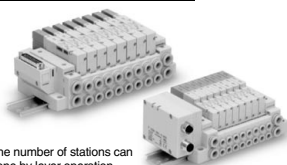

* Changing the number of stations can be easily done by lever operation.

Manifold Specifications

Applicable series		SV1000	SV2000
Manifold type		Stacking type cassette base manifold	
1 (P: SUP), 3/5 (E: EXH) type		Common SUP, EXH	
Valve stations (maximum)		18 stations	20 stations
Max. number of solenoids		18 points	26 points
Port size	1(P), 3/5(E) port	C8, N9	C10, N11
	4(A), 2(B) port	C3, C4, C6 N1, N3, N7	C4, C6, C8 N3, N7, N9

Flow Characteristics

Model	Port size		Flow characteristics					
	1, 5, 3 (P,EA,EB)	4, 2 (A,B)	1→4/2 (P→A/B)			4/2→3/5 (A/B→E)		
			C [dm ³ /(s·bar)]	b	Cv	C [dm ³ /(s·bar)]	b	Cv
SS5V1-16	C8	C6	0.89	0.22	0.22	0.98	0.21	0.23
SS5V2-16	C10	C8	2.3	0.28	0.50	2.7	0.18	0.56

Note) The value is for manifold base with 5 stations and individually operated 2 position type.

Tie-rod base manifold



* 34 pins connector allows up to 16 stations with double solenoids.

Manifold Specifications

Applicable series		SV1000	SV2000	SV3000	SV4000
Manifold type		Tie-rod base manifold			
1 (P: SUP), 3/5 (E: EXH) type		Common SUP, EXH			
Valve stations (maximum)		20 stations			
Max. number of solenoids		32 points			
Port size	1(P), 3/5(E) port	C8, N9	C10, N11	C12, N11	C12, N11,03
	4(A), 2(B) port	C3, C4, C6 N1, N3, N7	C4, C6, C8 N3, N7, N9	C6, C8, C10 N7, N9, N11	C8, C10, C12 N9, N11, 02, 03

Flow Characteristics

Model	Port size		Flow characteristics					
	1, 5, 3 (P,EA,EB)	4, 2 (A,B)	1→4/2 (P→A/B)			4/2→3/5 (A/B→E)		
			C [dm ³ /(s·bar)]	b	Cv	C [dm ³ /(s·bar)]	b	Cv
SS5V1-10	C8	C6	0.98	0.26	0.24	1.1	0.35	0.28
SS5V2-10	C10	C8	2.1	0.20	0.46	2.4	0.18	0.48
SS5V3-10	C12	C10	4.2	0.22	0.91	4.3	0.21	0.93
SS5V4-10	C12	C12	6.2	0.19	1.3	7.0	0.18	1.6

Note) The value is for manifold base with 5 stations and individually operated 2 position type.

Enclosure of Manifold Variations (Common for cassette base and tie-rod base)

Series	Enclosure (Based on IEC60529)
EX500 Gateway-type Serial Transmission System	IP67 *
EX250 Integrated-type (for I/O) Serial Transmission System	IP67 (partly IP40)
EX600 Integrated-type (for I/O) Serial Transmission System	IP67
EX260 Integrated-type (for Output) Serial Transmission System	IP67 (partly IP40)
EX126 Integrated-type (for Output) Serial Transmission System	IP67
EX120 Integrated-type (for Output) Serial Transmission System	IP20
Circular connector	IP67
D-sub connector	Dusttight (IP40)
Flat ribbon cable	Dusttight (IP40)

* Enclosure of a gateway unit and input manifold is IP65.

Series SV Solenoid Valve Specifications

 **Made to Order Specifications**
(For details, refer to page 646.)

Symbol

SV1000/2000/3000/4000

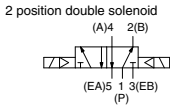
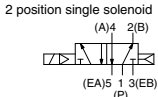

SV1000/2000/3000

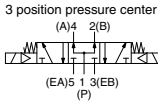
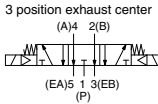
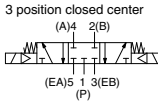

SV4000

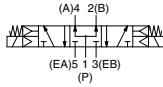
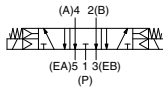
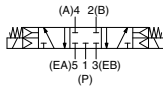

SV1000

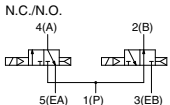
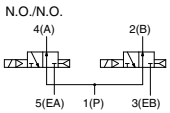
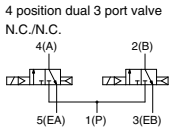

SV2000

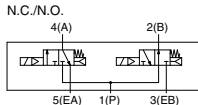
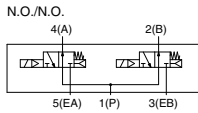
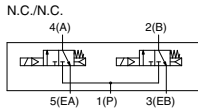

* SV3000 and 4000 are not available with 4 position dual 3 port valve.

Fluid		Air
Internal pilot	2 position single	0.15 to 0.7
Operating pressure range (MPa)	4 position dual 3 port valve	
External pilot	2 position double	0.1 to 0.7
	3 position	0.2 to 0.7
Operating pressure range (MPa)	2 position single, double	-100 kPa to 0.7
	3 position	0.25 to 0.7
Ambient and fluid temperature (°C)	-10 to 50 (No freezing. Refer to page 5.)	
Max. operating frequency (Hz)	2 position single, double	5
	4 position dual 3 port valve	
	3 position	3
Manual override	Non-locking push type	
	Push-turn locking slotted type	
Pilot exhaust method	Internal pilot	Common exhaust type for main and pilot valve
	External pilot	Pilot valve individual exhaust
Lubrication	Not required	
Mounting orientation	Unrestricted	
Impact/Vibration resistance (ms²)	150/30	
Enclosure	IP67 (Based on IEC60529)	
Coil rated voltage	24 VDC, 12 VDC	
Allowable voltage fluctuation	±10% of rated voltage	
Power consumption	0.6 (With indicator light: 0.65)	
Surge voltage suppressor	Zener diode	
Indicator light	LED	

Note) Impact resistance: No malfunction occurred when it is tested with a drop tester in the axial direction and at the right angles to the main valve and armature in both energized and de-energized states every once for each condition. (Values at the initial period)

Vibration resistance: No malfunction occurred in a one-sweep test between 45 and 2000 Hz. Test was performed at both energized and de-energized states in the axial direction and at the right angles to the main valve and armature. (Values at the initial period)

Response Time

Type of actuation	Response time (ms) (at the pressure of 0.5 MPa)			
	SV1000	SV2000	SV3000	SV4000
2 position single	11 or less	25 or less	28 or less	40 or less
2 position double	10 or less	17 or less	26 or less	40 or less
3 position	18 or less	29 or less	32 or less	82 or less
4 position dual 3 port valve	15 or less	33 or less	—	—

Note) Based on dynamic performance test, JIS B 8375-1981.
(Coil temperature: 20°C, at rated voltage)

Weight

Series	Type of actuation	Weight (g)
SV1000	Single solenoid	66
	Double solenoid	71
	3 position	73
	4 position dual 3 port	71
SV2000	Single solenoid	74
	Double solenoid	78
	3 position	83
	4 position dual 3 port	78
SV3000	Single solenoid	99
	Double solenoid	102
	3 position	110
SV4000	Single solenoid	186
	Double solenoid	190
	3 position	211

Note) Weight of solenoid valve only.

SV
SVJ
SZ
VF
VP4
S0700
VQ
VQ4
VQ5
VQC
VQC4
VQZ
SQ
VFS
VFR
VQ7

Gateway-type Serial Transmission System

Series EX500

IP67 compliant

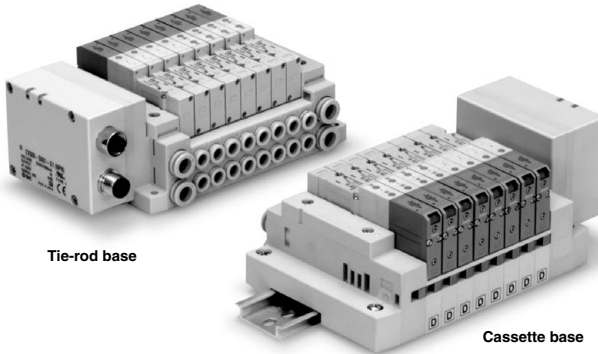

Tie-rod base

Cassette base

Applicable series

Cassette base manifold
SV1000/SV2000

Tie-rod base manifold
SV1000/SV2000/SV3000/SV4000

- Number of output points: 16 points
- Connected to the EX500GW unit

SJ
SY
SY
SV
SYJ
SZ
VF
VP4
S0700
VQ
VQ4
VQ5
VQC
VQC4
VQZ
SQ
VFS
VFR
VQ7

EX500 Gateway-type Serial Transmission System Series SV



How to Order Manifold

Series

1	SV1000
2	SV2000
3	SV3000
4	SV4000

● Tie-rod base
SS5V 1 - W 10S A2W D - 05 U

● Cassette base
SS5V 1 - W 16S A2W D - 05 U

Series

1	SV1000
2	SV2000

SI unit

0	Without SI unit
A2W	DeviceNet/PROFIBUS DP/CC-Link/EtherNet/IP

Enclosure IP67 specifications

● P, E port location

U	U side (2 to 10 stations)
D	D side (2 to 10 stations)
B	Both sides (2 to 16 stations)

● SUP/EXH block assembly specifications

Nil	Internal pilot
S ⁺	Internal pilot/Built-in silencer
R	External pilot
RS ⁺	External pilot/Built-in silencer

Note) When the built-in silencer type is used, keep the exhaust port from coming in direct contact with water or other liquids.

● A, B port size (metric)

Symbol	A, B port	P, E port	Applicable series
C3	One-touch fitting for ø3.2	One-touch fitting for ø8	SV1000
C4	One-touch fitting for ø4		
C6	One-touch fitting for ø6		
C4	One-touch fitting for ø4	One-touch fitting for ø10	SV2000
C6	One-touch fitting for ø6		
C8	One-touch fitting for ø8		
C6	One-touch fitting for ø6	One-touch fitting for ø12	SV3000
C8	One-touch fitting for ø8		
C10	One-touch fitting for ø10		
C10	One-touch fitting for ø10	One-touch fitting for ø12	SV4000
C12	One-touch fitting for ø12		
02	Rc 1/4		
03	Rc 3/8	Rc 3/8	SV4000
02F	G 1/4	G 3/8	
03F	G 3/8		
M	A, B ports mixed		

● A, B port size (inch)

Symbol	A, B port	P, E port	Applicable series
N1	One-touch fitting for ø1/8"	One-touch fitting for ø5/32"	SV1000
N3	One-touch fitting for ø5/32"		
N7	One-touch fitting for ø1/4"		
N3	One-touch fitting for ø5/32"	One-touch fitting for ø3/8"	SV2000
N7	One-touch fitting for ø1/4"		
N9	One-touch fitting for ø5/16"		
N7	One-touch fitting for ø1/4"	One-touch fitting for ø3/8"	SV3000
N9	One-touch fitting for ø5/16"		
N11	One-touch fitting for ø3/8"		
N9	One-touch fitting for ø5/16"	One-touch fitting for ø3/8"	SV4000
N11	One-touch fitting for ø3/8"		
02N	NPT 1/4		
03N	NPT 3/8	NPT 3/8	SV4000
02T	NPTF 1/4	NPTF 3/8	
03T	NPTF 3/8		
M	A, B ports mixed		

● Mounting

Nil	Direct mounting
D	DIN rail mounting (With DIN rail)
D0 ⁺	DIN rail mounting (Without DIN rail)
D3	For 3 stations
:	:
:	:
D16	For 16 stations

When a longer DIN rail is desired than the specified stations, (Specify a longer rail than the standard length.)

* In the case of D0, only DIN rail fittings are attached.

● DIN rail length specified

3	Standard length
Nil	For 3 stations
:	:
16	For 16 stations

Valve stations

Symbol	Stations	Note
02	2 stations	Double wiring specifications (1)
:	:	
08	8 stations	Specified layout (2) (up to 16 solenoids possible.)
02	2 stations	
:	:	
16	16 stations	

Note 1) Double wiring specifications: Single, double, 3 position and 4 position solenoid valves can be used on all manifold stations. Use of a single solenoid will result in an unused control signal. If this is not desired, order with a specified layout.

Note 2) Specified layout: Indicate wiring specifications on the manifold specification sheet. (Note that double, 3 position and 4 position valves cannot be used where single solenoid wiring has been specified.)

SI unit part no.

Symbol	Protocol type	SI unit
A2W	DeviceNet	EX500-S001
	PROFIBUS DP	
	CC-Link	
	EtherNet/IP	



How to Order Manifold Assembly

Ordering example (SV1000)

Manifold

SS5V1-W16SA2WD-06B-C6 (1 set)

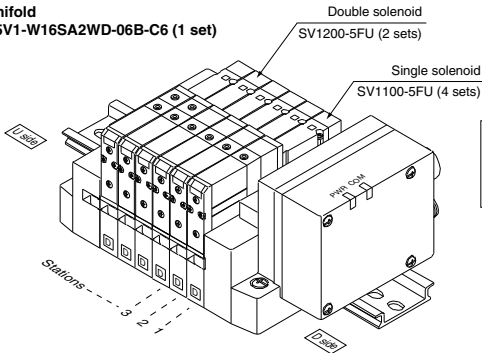

SS5V1-W16SA2WD-06B-C6.....1 set (Manifold part no.)
* SV1100-5FU.....4 sets (Single solenoid part no.)
* SV1200-5FU.....2 sets (Double solenoid part no.)

How to Order Valve

SV 1 1 0 0 - 5 F - - -

Series

1	SV1000
2	SV2000
3	SV3000
4	SV4000

Type of actuation

1	2 position single
2	2 position double
3	3 position closed center
4	3 position exhaust center
5	3 position pressure center
A	4 position dual 3 port valve: N.C./N.C.
B	4 position dual 3 port valve: N.O./N.O.
C	4 position dual 3 port valve: N.C./N.O.

* 4 position dual 3 port valves are applicable to Series SV1000 and SV2000 only.

Pilot type

Nil	Internal pilot
R	External pilot

* External pilot specifications is not available for 4 position dual 3 port valves.

Back pressure check valve

Nil	None
K	Built-in

* Built-in back pressure check valve type is applicable to series SV1000 only.

* Back pressure check valve is not available for 3 position valve.

Rated voltage

5	24 VDC
---	--------

Note) Available with manifold block for station additions. Refer to pages 625 and 631.

Made to Order

Nil	-
X90	Main valve fluororubber (Refer to page 646.)

Manual override

Nil: Non-locking push type

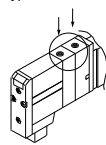

D: Push-turn locking slotted type

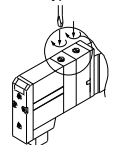

Light/Surge voltage suppressor

U	With light/surge voltage suppressor
R	With surge voltage suppressor

Note) Refer to Specific Product Precautions 2 on page 648.

- SV
- SVJ
- SZ
- VF
- VP4
- S0700
- VQ
- VQ4
- VQ5
- VQC
- VQC4
- VQZ
- SQ
- VFS
- VFR
- VQ7

Series SV

Dimensions: Series SV1000 for EX500 Gateway-type Serial Transmission System

● Cassette base manifold: SS5V1-W16SA2WD-^UStations₀(S, R, RS)^{C3, N1}_{C4, N3}^{C5, N7}

- When P, E port outlets are indicated on the U side or D side, the P, E ports on the opposite side are plugged.
- External pilot port positions and silencer discharge port positions are the same as P, E port outlet positions.

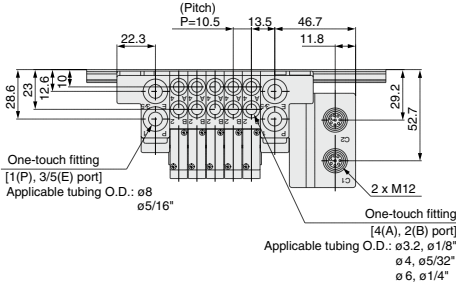

With External Pilot Specifications

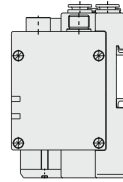
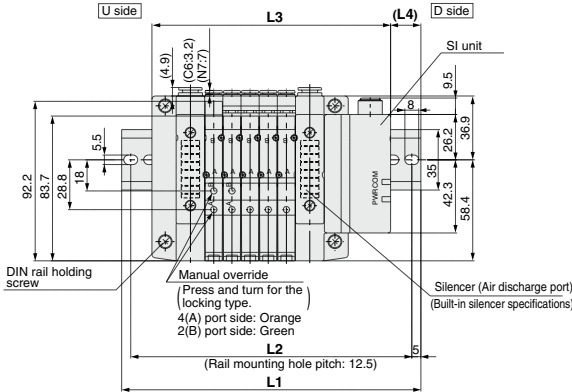
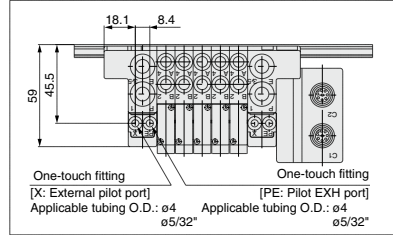

With option

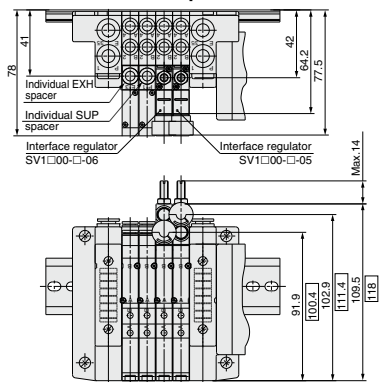

□ Dimensions are the ones for SV1300-□□□.

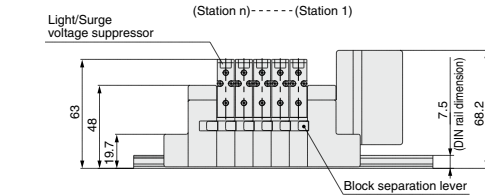

L Dimension

n	2	3	4	5	6	7	8	9	10	11	12	13	14	15	16
L1	135.5	148	160.5	173	173	185.5	198	210.5	223	235.5	248	260.5	273	285.5	
L2	125	137.5	150	162.5	162.5	175	187.5	200	212.5	225	225	237.5	250	262.5	275
L3	106.5	117	127.5	138	148.5	159	169.5	180	190.5	201	211.5	222	232.5	243	253.5
L4	14.5	15.5	16.5	17.5	12.5	13.5	14.5	15.5	16.5	17.5	12	13	14	15	16

n: Stations

Dimensions: Series SV2000 for EX500 Gateway-type Serial Transmission System

● **Cassette base manifold: SS5V2-W16SA2WD-** Stations $\frac{U}{D}$ (S, R, RS) $\frac{C4, N3}{C6, N7}$

- When P, E port outlets are indicated on the U side or D side, the P, E ports on the opposite side are plugged.
- External pilot port positions and silencer discharge port positions are the same as P, E port outlet positions.

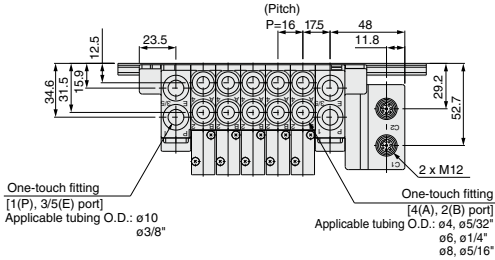

With External Pilot Specifications

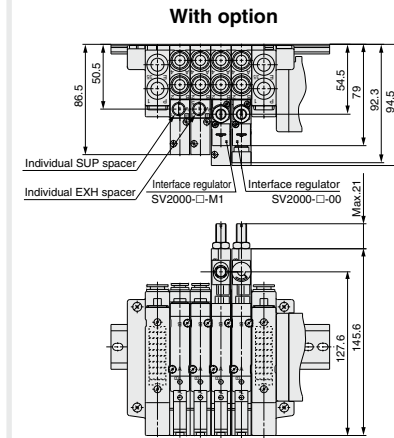
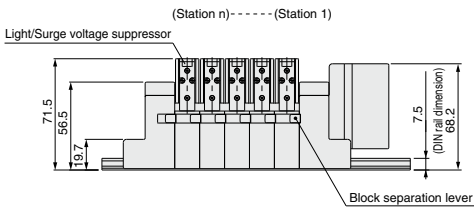
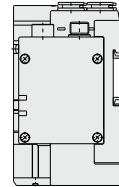
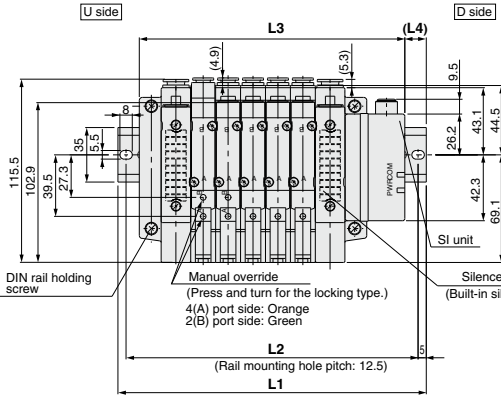
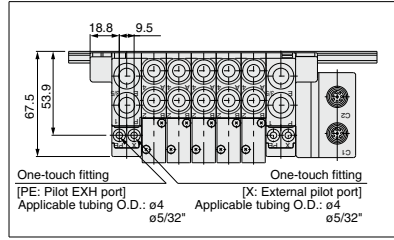

L Dimension

n: Stations

n	2	3	4	5	6	7	8	9	10	11	12	13	14	15	16
L1	148	173	185.5	198	210.5	235.5	248	260.5	285.5	298	310.5	323	348	360.5	373
L2	137.5	162.5	175	187.5	200	225	237.5	250	275	287.5	300	312.5	337.5	350	362.5
L3	122.5	138.5	154.5	170.5	186.5	202.5	218.5	234.5	250.5	266.5	282.5	298.5	314.5	330.5	346.5
L4	13	17.5	15.5	14	12	16.5	15	13	17.5	16	14	12.5	17	15	13.5

SJ
SY
SY
SV
SYJ
SZ
VF
VP4
S0700
VQ
VQ4
VQ5
VQC
VQC4
VQZ
SQ
VFS
VFR
VQ7

Series SV

Dimensions: Series SV1000 for EX500 Gateway-type Serial Transmission System

● Tie-rod base manifold: SS5V1-W10SA2WD-^UStations^L₁₀ (S, R, RS) ^{C3, N1}_{C4, N2} ^{C6, N3}_{C6, N3} (-D)

- When P, E port outlets are indicated on the U side or D side, the P, E ports on the opposite side are plugged.
- External pilot port positions and silencer discharge port positions are the same as P, E port outlet positions.

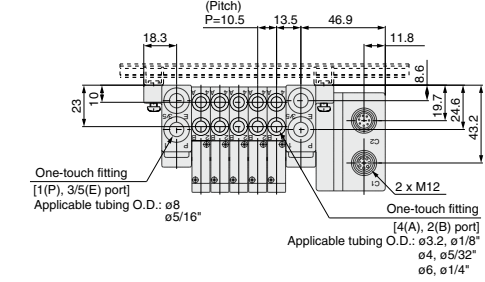

With External Pilot Specifications

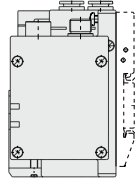
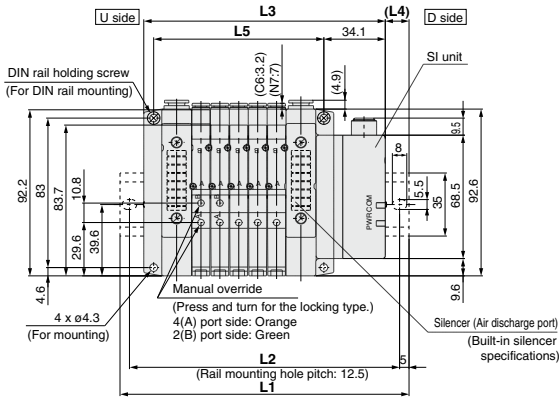
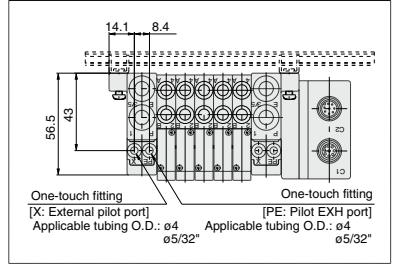

With option

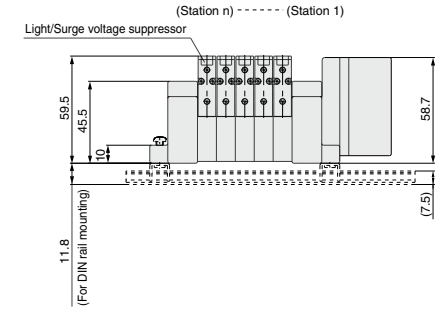
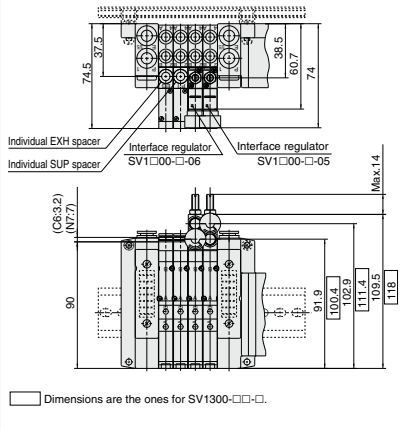

L Dimension

n	2	3	4	5	6	7	8	9	10	11	12	13	14	15	16
L1	135.5	148	148	160.5	173	185.5	198	210.5	210.5	223	235.5	248	260.5	273	273
L2	125	137.5	137.5	150	162.5	175	187.5	200	200	212.5	225	237.5	250	262.5	262.5
L3	102.6	113.1	123.6	134.1	144.6	155.1	165.6	176.1	186.6	197.1	207.6	218.1	228.6	239.1	249.6
L4	16.5	17.5	12	13	14	15	16	17	12	13	14	15	16	17	11.5
L5	63	73.5	84	94.5	105	115.5	126	136.5	147	157.5	168	178.5	189	199.5	210

Dimensions: Series SV2000 for EX500 Gateway-type Serial Transmission System

● Tie-rod base manifold: SS5V2-W10SA2WD-^UStations_D(S, R, RS)-^{C4, N3, C6, N7, C8, N6}(-D)

- When P, E port outlets are indicated on the U side or D side, the P, E ports on the opposite side are plugged.
- External pilot port positions and silencer discharge port positions are the same as P, E port outlet positions.

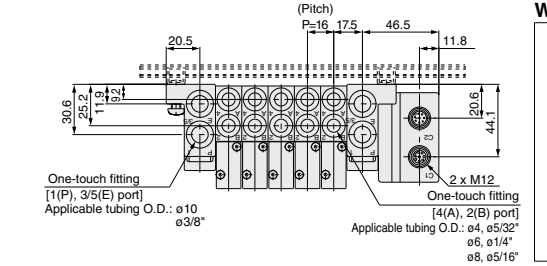

With External Pilot Specifications

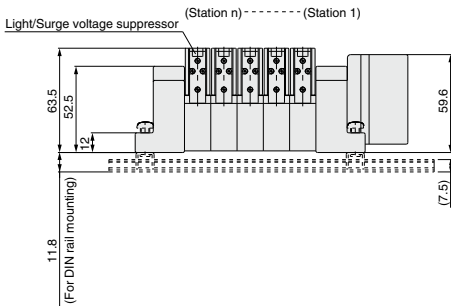
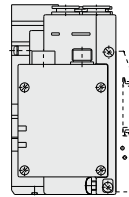
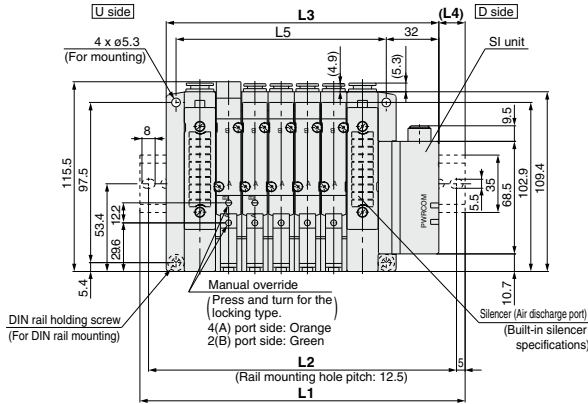
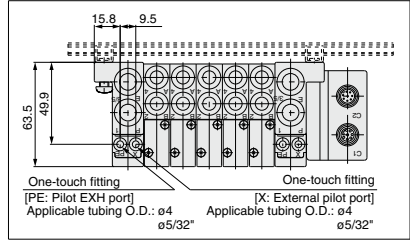

With option

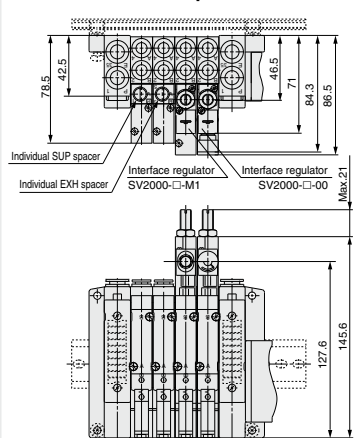

L Dimension

n: Stations

n	2	3	4	5	6	7	8	9	10	11	12	13	13	14	15	16
L1	148	160.5	185.5	198	210.5	223	248	260.5	273	285.5	310.5	323	335.5	360.5	373	
L2	137.5	150	175	187.5	200	212.5	237.5	250	262.5	275	300	312.5	325	350	362.5	
L3	118	134	150	166	182	198	214	230	246	262	278	294	310	326	342	
L4	15	13.5	18	16	14.5	12.5	17	15.5	13.5	12	16.5	14.5	13	17.5	15.5	
L5	80	96	112	128	144	160	176	192	208	224	240	256	272	288	304	

Series SV

Dimensions: Series SV3000 for EX500 Gateway-type Serial Transmission System

● Tie-rod base manifold: SS5V3-W10SA2WD- $\frac{U}{S}$ (S, R, RS) $\frac{C6, N7}{C8, N9}$ (-D)

- When P, E port outlets are indicated on the U side or D side, the P, E ports on the opposite side are plugged.
- External pilot port positions and silencer discharge port positions are the same as P, E port outlet positions.

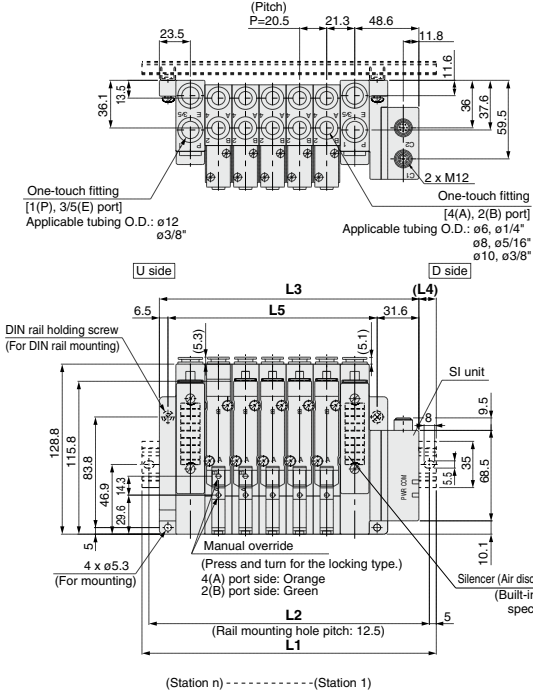

With External Pilot Specifications

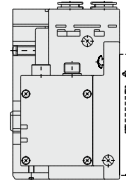
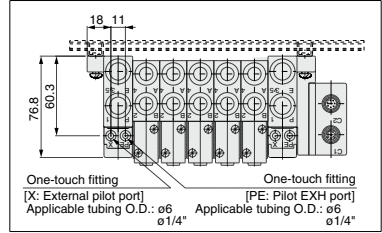

With option

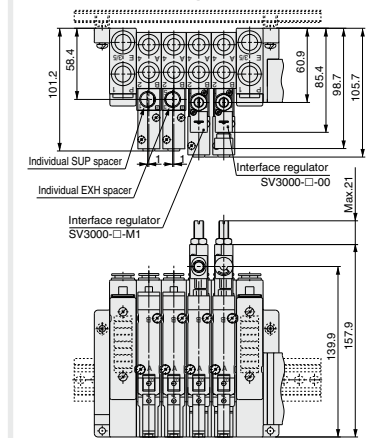

L Dimension

n	2	3	4	5	6	7	8	9	10	11	12	13	14	15	16
L1	160.5	185.5	210.5	223	248	273	285.5	310.5	323	348	373	385.5	410.5	435.5	448
L2	150	175	200	212.5	237.5	262.5	275	300	312.5	337.5	362.5	375	400	425	437.5
L3	135.1	155.6	176.1	196.6	217.1	237.6	258.1	278.6	299.1	319.6	340.1	360.6	381.1	401.6	422.1
L4	12.5	15	17	13	15.5	17.5	13.5	16	12	14	16.5	12.5	14.5	17	13
L5	97	117.5	138	158.5	179	199.5	220	240.5	261	281.5	302	322.5	343	363.5	384

Dimensions: Series SV4000 for EX500 Gateway-type Serial Transmission System

● Tie-rod base manifold: SS5V4-W10SA2WD-(Stations) (S, R, RS) (C₁, C₂, C₈, C₁₀, C₁₂, N₉, N₁₁)-(D)

- When P, E port outlets are indicated on the U side or D side, the P, E ports on the opposite side are plugged.
- External pilot port positions and silencer discharge port positions are the same as P, E port outlet positions.

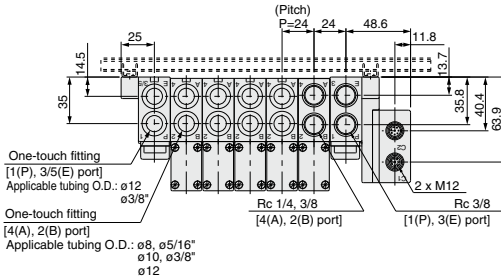

With External Pilot Specifications

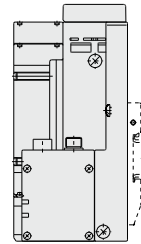
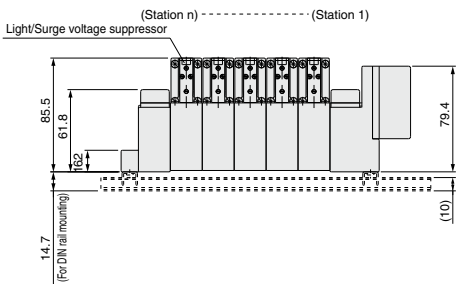
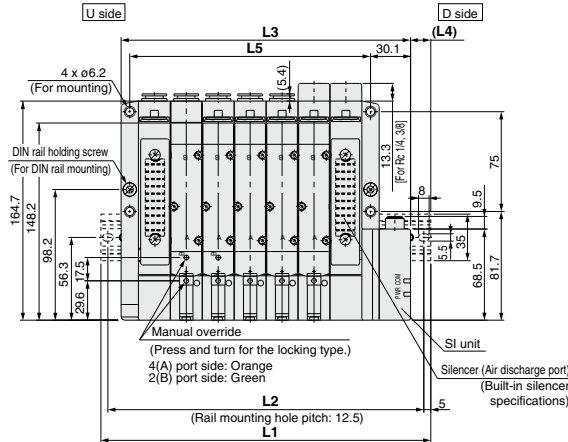
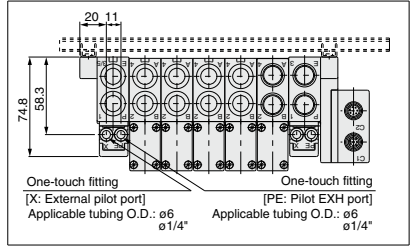

With option

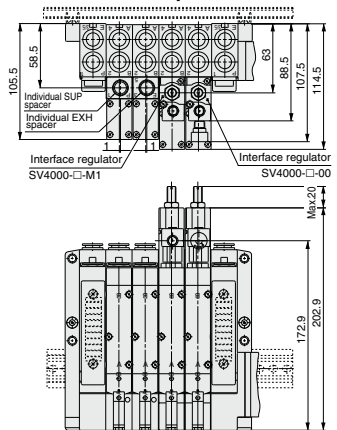

L Dimension

n	2	3	4	5	6	7	8	9	10	11	12	13	14	15	16
L1	173	198	223	248	273	298	323	348	373	385.5	410.5	435.5	460.5	485.5	510.5
L2	162.5	187.5	212.5	237.5	262.5	287.5	312.5	337.5	362.5	375	400	425	450	475	500
L3	145.6	169.6	193.6	217.6	241.6	265.6	289.6	313.6	337.6	361.6	385.6	409.6	433.6	457.6	481.6
L4	13.5	14	14.5	15	15.5	16	16.5	17	17.5	12	12.5	13	13.5	14	14.5
L5	109	133	157	181	205	229	253	277	301	325	349	373	397	421	445

- JS
- SY
- SY
- SV**
- SYJ
- SZ
- VF
- VP4
- S0700
- VQ
- VQ4
- VQ5
- VQC
- VQC4
- VQZ
- SQ
- VFS
- VFR
- VQ7

Integrated-type (For I/O) Serial Transmission System

Series EX250

IP67 (partly IP40) compliant

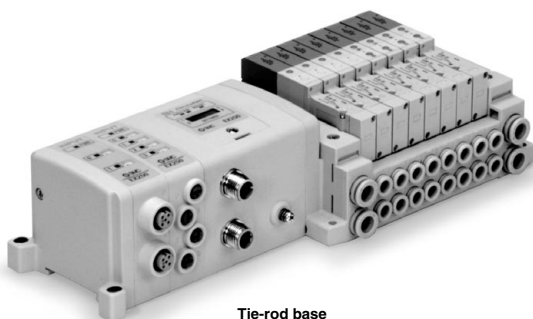

Tie-rod base

Applicable series **Tie-rod base manifold**
SV1000/SV2000/SV3000

- Number of inputs/outputs points: 32 points each

SJ
SY
SY
SV
SYJ
SZ
VF
VP4
S0700
VQ
VQ4
VQ5
VQC
VQC4
VQZ
SQ
VFS
VFR
VQ7

EX250 Integrated-type (For I/O) Serial Transmission System

Series SV



How to Order Manifold

● Tie-rod base

SS5V 1 - W10S1QW [] [] [] D - 05 U [] - [] - []

Series ●

1	SV1000
2	SV2000
3	SV3000

SI unit ●

Symbol	Protocol type
W10S10	Without SI unit
W10S1QW	DeviceNet
W10S1NW	PROFIBUS DP
W10S1VW	CC-Link
W10S1TAW	AS-Interface (8in/8out 31Slave Mode 2 power supply systems)
W10S1TBW	AS-Interface (4in/4out 31Slave Mode 2 power supply systems)
W10S1TCW (1)	AS-Interface (8in/8out 31Slave Mode 1 power supply systems)
W10S1TDW (1)	AS-Interface (4in/4out 31Slave Mode 1 power supply systems)
W10S1YW	CANopen
10S1ZCN (2)	ControlNet (IP40)
W10S1ZEN	EtherNet/IP

- *Input blocks cannot be mounted without SI unit.
- *When the DIN rail is included without an SI unit, the DIN rail length will accommodate an SI unit and one input block.
- Note 1) There is a limit to the supply current to the input block and valve from SI units that have AS-Interface-compliant 1 power supply systems. Refer to page 2077 for details.
- Note 2) When the SI unit is ControlNet compliant, it is also IP40-compliant. (All other SI units are IP67-compliant.)

Input block stations ●

Nil	None
1	1 station
⋮	⋮
8	8 stations

Note) Without SI unit, the symbol is nil.
When the SI unit is AS-Interface compliant, the maximum number of stations is limited.
Refer to page 2077 for details.

Input block type ●

Nil	Without input block	
1	M12: 2 inputs	EX250-IE1
2	M12: 4 inputs	EX250-IE2
3	M8: 4 inputs	EX250-IE3

Note) Without SI unit, the symbol is nil.

Input block specifications ●

Nil	PNP input (+COM) or without input block
N	NPN input (-COM)

SI Unit Part No.

Symbol	Protocol type	Solenoid part no.
W10S1QW	DeviceNet	EX250-SDN1
W10S1NW	PROFIBUS DP	EX250-SPR1
W10S1VW	CC-Link	EX250-SMJ2
W10S1TAW	AS-Interface (8in/8out 31Slave Mode 2 power supply systems)	EX250-SAS3
W10S1TBW	AS-Interface (4in/4out 31Slave Mode 2 power supply systems)	EX250-SAS5
W10S1TCW	AS-Interface (8in/8out 31Slave Mode 1 power supply systems)	EX250-SAS7
W10S1TDW	AS-Interface (4in/4out 31Slave Mode 1 power supply systems)	EX250-SAS9
W10S1YW	CANopen	EX250-SCA1A
10S1ZCN	ControlNet (IP40)	EX250-SCN1
W10S1ZEN	EtherNet/IP	EX250-SEN1

A, B port size (metric) ●

Symbol	A, B port	P, E port	Applicable series
C3	One-touch fitting for ø3.2	One-touch fitting for ø8	SV1000
C4	One-touch fitting for ø4		
C6	One-touch fitting for ø6	One-touch fitting for ø10	SV2000
C4	One-touch fitting for ø4		
C6	One-touch fitting for ø6	One-touch fitting for ø12	SV3000
C8	One-touch fitting for ø8		
C8	One-touch fitting for ø8	One-touch fitting for ø12	SV3000
C10	One-touch fitting for ø10		
M	A, B ports mixed		

- * In the case of mixed specifications (M), indicate separately on the manifold specification sheet.
- * Port sizes of X, PE port for external pilot specifications (R, RS) are ø4 (metric), ø5/32" (inch) for SV1000/2000 and ø6 (metric) and ø1/4" (inch) for SV3000.

A, B port size (inch) ●

Symbol	A, B port	P, E port	Applicable series
N1	One-touch fitting for ø1/8"	One-touch fitting for ø5/16"	SV1000
N3	One-touch fitting for ø5/32"		
N7	One-touch fitting for ø1/4"	One-touch fitting for ø3/8"	SV2000
N3	One-touch fitting for ø5/32"		
N7	One-touch fitting for ø1/4"	One-touch fitting for ø3/8"	SV3000
N9	One-touch fitting for ø5/16"		
N7	One-touch fitting for ø1/4"	One-touch fitting for ø3/8"	SV3000
N9	One-touch fitting for ø5/16"		
N11	One-touch fitting for ø3/8"		
M	A, B ports mixed		

Refer to page 2074 and the Operation Manual for the details of EX250 Integrated-type Serial Transmission System. Please download the Operation Manual via our website, <http://www.smcworld.com>.

How to Order Manifold Assembly

Ordering example (SV1000)

Manifold

SS5V1-W10S1QW11ND-05B-C6 (1 set)

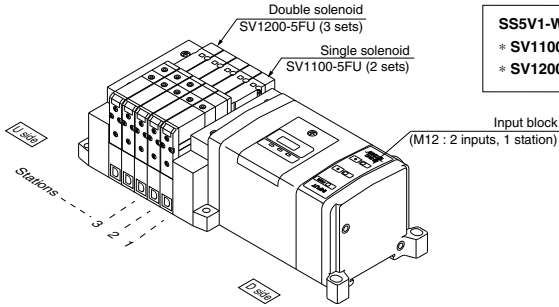

SS5V1-W10S1QW11ND-05B-C6...1 set (manifold part no.)
* SV1100-5FU.....2 sets (Single solenoid part no.)
* SV1200-5FU.....3 sets (Double solenoid part no.)

How to Order Valve

SV 1 1 0 0 - 5 F - - -

Series ●

1	SV1000
2	SV2000
3	SV3000

Type of actuation ●

1	2 position single
2	2 position double
3	3 position closed center
4	3 position exhaust center
5	3 position pressure center
A	4 position dual 3 port valve: N.C./N.C.
B	4 position dual 3 port valve: N.O./N.O.
C	4 position dual 3 port valve: N.C./N.O.

* 4 position dual 3 port valves are applicable to Series SV1000 and SV2000 only.

Pilot type ●

Nil	Internal pilot
R	External pilot

* External pilot specifications is not available for 4 position dual 3 port valves.

Back pressure check valve ●

Nil	None
K	Built-in

* Built-in back pressure check valve type is applicable to series SV1000 only.
* Back pressure check valve is not available for 3 position valve.

Note) Available with manifold block for station additions. Refer to page 631.

Made to Order ●

Nil	-
X90	Main valve fluororubber (Refer to page 646.)

● Manual override

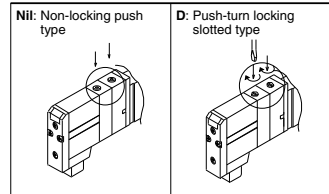

● Light/Surge voltage suppressor

U	With light/surge voltage suppressor
R	With surge voltage suppressor

● Rated voltage

5	24 VDC
---	--------

Note) Refer to Specific Product Precautions 2 on page 648.

- SJ
- SY
- SY
- SV
- SYJ
- SZ
- VF
- VP4
- S0700
- VQ
- VQ4
- VQ5
- VQC
- VQC4
- VQZ
- SQ
- VFS
- VFR
- VQ7

Series SV

Dimensions: Series SV1000 for EX250 Integrated-type (For I/O) Serial Transmission System

● Tie-rod base manifold: SS5V1-W10S1□□□□D- Stations $\begin{matrix} U \\ D \end{matrix}$ (S, R, RS)- $\begin{matrix} C3, N1 \\ C4, N3 \\ C6, N7 \end{matrix}$ (-D)

- When P, E port outlets are indicated on the U side or D side, the P, E ports on the opposite side are plugged.
- External pilot port positions and silencer discharge port positions are the same as P, E port outlet positions.

(With 2 input blocks)

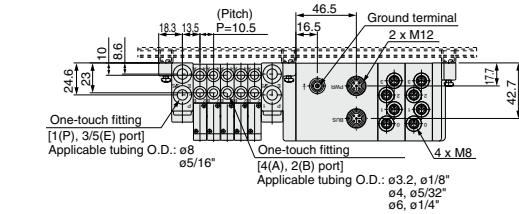

With External Pilot Specifications

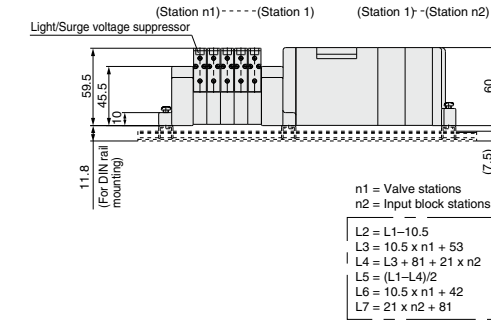
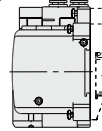
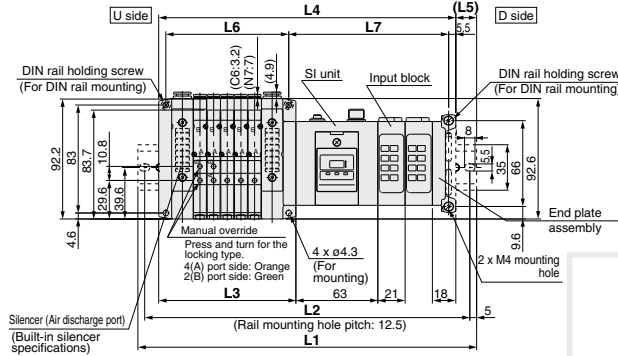
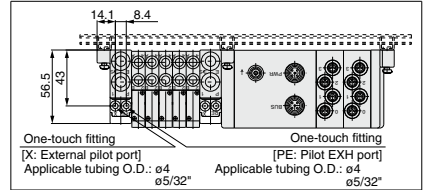

With option

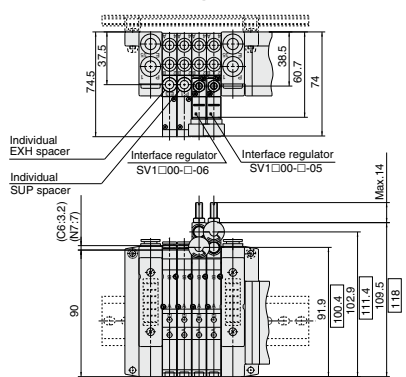

□ Dimensions are the ones for SV1300-□□-□.

L1: DIN Rail Overall Length

Valve stations (n1) Input block Stations (n2)	2	3	4	5	6	7	8	9	10	11	12	13	14	15	16	17	18	19	20
0	185.5	198	210.5	210.5	223	235.5	248	260.5	273	273	285.5	298	310.5	323	335.5	348	348	360.5	373
1	210.5	210.5	223	235.5	248	260.5	273	273	285.5	298	310.5	323	335.5	348	348	360.5	373	385.5	398
2	223	235.5	248	260.5	273	273	285.5	298	310.5	323	335.5	348	348	360.5	373	385.5	398	410.5	410.5
3	248	260.5	273	273	285.5	298	310.5	323	335.5	348	348	360.5	373	385.5	398	410.5	410.5	423	435.5
4	273	273	285.5	298	310.5	323	335.5	348	348	360.5	373	385.5	398	410.5	410.5	423	435.5	448	460.5
5	285.5	298	310.5	323	335.5	348	348	360.5	373	385.5	398	410.5	410.5	423	435.5	448	460.5	473	485.5
6	310.5	323	335.5	348	348	360.5	373	385.5	398	410.5	410.5	423	435.5	448	460.5	473	473	485.5	498
7	335.5	348	348	360.5	373	385.5	398	410.5	410.5	423	435.5	448	460.5	473	485.5	498	510.5	523	523
8	348	360.5	373	385.5	398	410.5	410.5	423	435.5	448	460.5	473	473	485.5	498	510.5	523	535.5	535.5

EX250 Integrated-type (For I/O) Serial Transmission System *Series SV*

Dimensions: Series SV2000 for EX250 Integrated-type (For I/O) Serial Transmission System

● Tie-rod base manifold: SS5V2-W10S1□□□□D-**Stations** $\frac{D}{B}$ (S, R, RS)- $\frac{C4, N3}{C8, N8}$ $\frac{C6, N6}{C8, N9}$ (-D)

(With 2 input blocks)

- When P, E port outlets are indicated on the U side or D side, the P, E ports on the opposite side are plugged.
- External pilot port positions and silencer discharge port positions are the same as P, E port outlet positions.

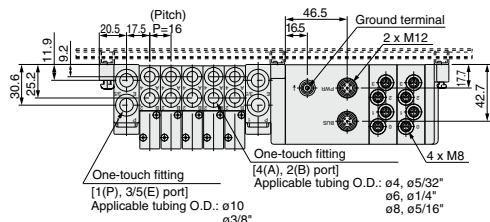

With External Pilot Specifications

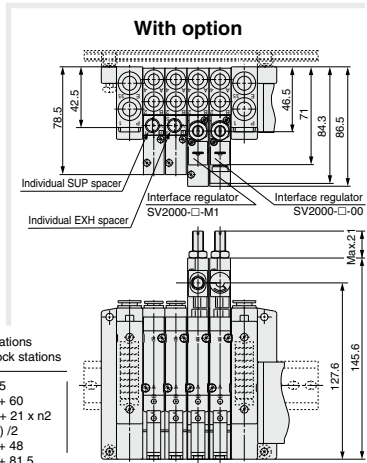
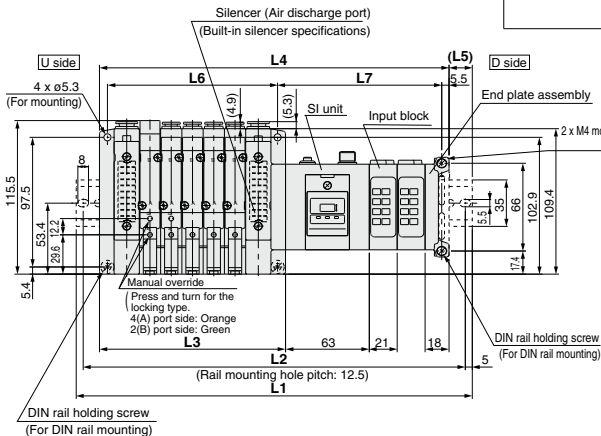
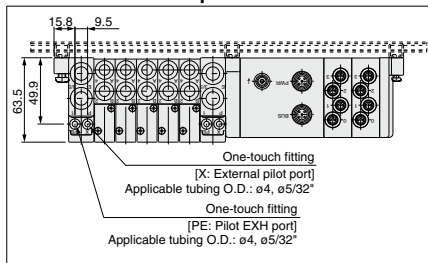

n1 = Valve stations
n2 = Input block stations

- L2 = L1 - 10.5
- L3 = 16 x n1 + 60
- L4 = L3 + 81 + 21 x n2
- L5 = (L1 - L4) / 2
- L6 = 16 x n1 + 48
- L7 = 21 x n2 + 81.5

L1: DIN Rail Overall Length

Valve stations (n1) Input block Stations (n2)	2	3	4	5	6	7	8	9	10	11	12	13	14	15	16	17	18	19	20
0	198	223	235.5	248	260.5	285.5	298	310.5	335.5	348	360.5	373	398	410.5	423	448	460.5	473	485.5
1	223	235.5	260.5	273	285.5	298	323	335.5	348	373	385.5	398	410.5	435.5	448	460.5	485.5	498	510.5
2	248	260.5	273	298	310.5	323	335.5	360.5	373	385.5	410.5	423	435.5	460.5	473	485.5	498	510.5	535.5
3	260.5	285.5	298	310.5	335.5	348	360.5	373	398	410.5	423	435.5	460.5	473	485.5	510.5	523	535.5	548
4	285.5	298	323	335.5	348	360.5	385.5	398	410.5	435.5	448	460.5	473	498	510.5	523	548	560.5	573
5	310.5	323	335.5	360.5	373	385.5	398	423	435.5	448	473	485.5	498	510.5	535.5	548	560.5	585.5	598
6	323	348	360.5	373	398	410.5	423	435.5	460.5	473	485.5	510.5	523	535.5	548	573	585.5	598	610.5
7	348	360.5	385.5	398	410.5	435.5	448	460.5	473	498	510.5	523	535.5	560.5	573	585.5	610.5	623	635.5
8	373	385.5	398	423	435.5	448	460.5	485.5	498	510.5	535.5	548	560.5	573	598	610.5	623	648	660.5

Series SV

Dimensions: Series SV3000 for EX250 Integrated-type (For I/O) Serial Transmission System

● Tie-rod base manifold: SS5V3-W10S1□□□□D-Stations $\frac{U}{D}$ (S, R, RS)- $\frac{C6, N7}{C8, N9}$ (-D)
 $\frac{C10, N11}{C10, N11}$ (-D)

(With 2 input blocks)

- When P, E port outlets are indicated on the U side or D side, the P, E ports on the opposite side are plugged.
- External pilot port positions and silencer discharge port positions are the same as P, E port outlet positions.

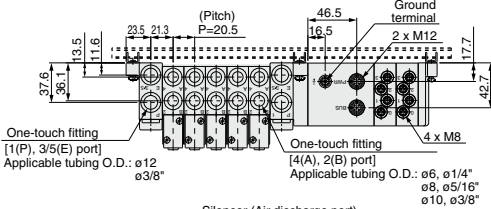

With External Pilot Specifications

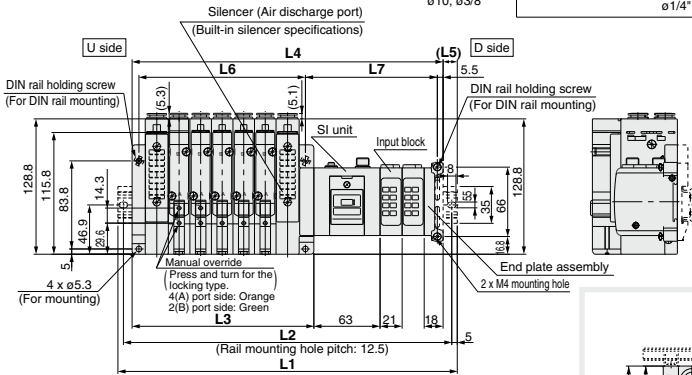
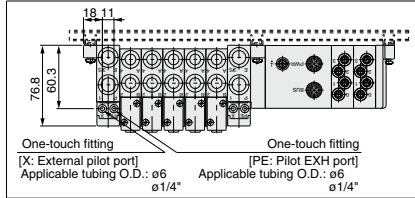

With option

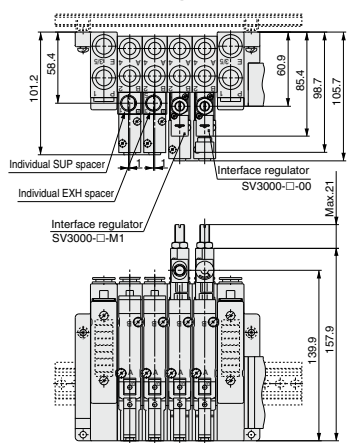

n1 = Valve stations
 n2 = Input block stations

- L2 = L1 - 10.5
- L3 = 20.5 x n1 + 70.5
- L4 = L3 + 81 + 21 x n2
- L5 = (L1 - L4) / 2
- L6 = 20.5 x n1 + 56
- L7 = 21 x n2 + 83.5

L1: DIN Rail Overall Length

Valve stations (n1) Input block Stations (n2)	2	3	4	5	6	7	8	9	10	11	12	13	14	15	16	17	18	19	20
0	223	248	260.5	285.5	298	323	348	360.5	385.5	410.5	423	448	473	485.5	510.5	535.5	548	573	585.5
1	248	260.5	285.5	310.5	323	348	360.5	385.5	410.5	423	448	473	485.5	510.5	535.5	548	573	585.5	610.5
2	260.5	285.5	310.5	323	348	360.5	385.5	410.5	423	448	473	485.5	510.5	535.5	548	573	598	610.5	635.5
3	285.5	310.5	323	348	373	385.5	410.5	423	448	473	485.5	510.5	535.5	548	573	598	610.5	635.5	648
4	310.5	323	348	373	385.5	410.5	423	448	473	485.5	510.5	535.5	548	573	598	610.5	635.5	660.5	673
5	323	348	373	385.5	410.5	435.5	448	473	485.5	510.5	535.5	548	573	598	610.5	635.5	660.5	673	698
6	348	373	385.5	410.5	435.5	448	473	485.5	510.5	535.5	548	573	598	610.5	635.5	660.5	673	698	723
7	373	385.5	410.5	435.5	448	473	498	510.5	535.5	548	573	598	610.5	635.5	660.5	673	698	723	735.5
8	385.5	410.5	435.5	448	473	498	510.5	535.5	548	573	598	610.5	635.5	660.5	673	698	723	735.5	760.5

Integrated-type (For I/O) Serial Transmission System

Series EX600

IP67 compliant



Tie-rod base

Applicable series **Tie-rod base manifold**
SV1000/SV2000/SV3000

- Digital input/output: Max. 144 inputs/144 outputs
- Analog input: Max. 18 channels
- Valve output: 32 outputs

SJ
SY
SY
SV
SYJ
SZ
VF
VP4
S0700
VQ
VQ4
VQ5
VQC
VQC4
VQZ
SQ
VFS
VFR
VQ7

Series EX600



Series SV1000/2000/3000

When I/O Unit EX600-D□□E or EX600-D□□F are selected, enclosure is IP40. Refer to page 652 for details.

Refer to page 2087 and the Operation Manual for the details of EX600 Integrated-type (For I/O) Serial Transmission System. Please download the Operation Manual via our website, <http://www.smcworld.com>

How to Order

● Tie-rod Base

SS5V 1 - W10S6 Q - - - - - D - 05 U - - - - - C6 - - - - -

Series

1	SV1000
2	SV2000
3	SV3000

Protection class IP67

SI Unit

0	Without SI Unit
Q	DeviceNet™ type
N	PROFIBUS DP type
V	CC-Link type

- I/O units cannot be chosen without SI Unit.
- Without SI Unit type does not include the Valve Plate to connect the valve manifold and SI Unit. Refer to Specific Product Precautions on page 2109 for mounting method.

End plate type

Nil	No end plate
2	M12 connector power supply (Max. supply current 2A)
3	7/8 inch connector power supply (Max. supply current 8A)

Note) Without SI Unit, the symbol is nil.

SI Unit COM.

Nil	Positive common
N	Negative common

Note) Without SI Unit, the symbol is nil.

I/O unit sta. number

Nil	None
1	1 sta.
:	:
9	9 sta.

Note 1) Without SI Unit, the symbol is nil.
 Note 2) SI Unit is not included in I/O unit station number.
 Note 3) When I/O unit is selected, it is shipped separately, and assembled by customer. Refer to the attached instruction manual for mounting method.

Mounting

Nil	Direct mounting
D	DIN rail mounting (With DIN rail)
D0 ^{Note 1)}	DIN rail mounting (Without DIN rail)
D3	For 3 sta. When a longer DIN rail is desired than the specified stations. (Specify a longer rail than the standard length.)
:	:
D20	For 20 sta.

Note 1) In the case of D0, only DIN rail mounting bracket is attached.
 Note 2) DIN rail is not attached (but shipped together) on the manifold in the case of with DIN rail. Refer to the SV series catalog for mounting method.
 Note 3) When DIN rail mounting (with DIN rail) is selected for the SV3000 series, and I/O unit station number is 9, and max. valve station number is 18, DIN rail mounting (with DIN rail) cannot be specified for 19 and 20 stations. (Refer to the DIN rail total length on pages 558 and 559.)
 Note 4) Without SI unit (S60), DIN rail (D) is not available.

SUP/EXH block assembly

Nil	Internal pilot
S ^{Note)}	Internal pilot, Built-in silencer
R	External pilot
RS ^{Note)}	External pilot, Built-in silencer

Note) When the built-in silencer type is used, keep the exhaust port from coming in direct contact with water or other liquids.

P, E port entry

U	U side (2 sta. to 10 sta.)
D	D side (2 sta. to 10 sta.)
B	B side (2 sta. to 20 sta.)

Valve stations

Symbol	Stations	Note
02	2 sta.	Double wiring specification ^{Note 1)}
:	:	
16	16 sta.	
02	2 sta.	Specified layout ^{Note 2)} (Up to 32 solenoids possible)
:	:	
20	20 sta.	

Note 1) Double wiring specifications: Single, double, 3 position and 4 position solenoid valves can be used at all of the manifold stations.
 When single solenoid is used, control signal which is not assigned to any number is made. If empty signal is not wanted, please order with signal layout specified.
 Note 2) Specified layout: Indicate wiring specifications with the manifold specification sheet. (Note that double, 3 position and 4 position valves cannot be used where single solenoid wiring has been specified.)

A, B port size (Metric)

Symbol	A, B port	P, E port	Applicable series
C3	ø3.2 One-touch fitting	ø8 One-touch fitting	SV1000
C4	ø4 One-touch fitting		
C6	ø6 One-touch fitting		
C4	ø4 One-touch fitting	ø10 One-touch fitting	SV2000
C6	ø6 One-touch fitting		
C8	ø8 One-touch fitting		
C6	ø6 One-touch fitting	ø12 One-touch fitting	SV3000
C8	ø8 One-touch fitting		
C10	ø10 One-touch fitting		
M	A, B port mixed		

A, B port size (Inch)

Symbol	A, B port	P, E port	Applicable series
N1	ø1/8" One-touch fitting	ø5/16" One-touch fitting	SV1000
N3	ø5/32" One-touch fitting		
N7	ø1/4" One-touch fitting		
N3	ø5/32" One-touch fitting	ø3/8" One-touch fitting	SV2000
N7	ø1/4" One-touch fitting		
N9	ø5/16" One-touch fitting		
N7	ø1/4" One-touch fitting	ø3/8" One-touch fitting	SV3000
N9	ø5/16" One-touch fitting		
N11	ø3/8" One-touch fitting		
M	A, B port mixed		

* In the case of Mixed specifications (M), indicate separately with the manifold specification sheet.

* Regarding the X and PE port size of External pilot type (R), and X port size of External pilot/Built-in silencer type (RS), ø4 (mm) and ø5/32" (inch) for the SV1000/2000 series, ø6 (mm) and, ø1/4" (inch) for the SV3000 series.

How to Order Manifold Assembly (Example)

Example (SS5V1)

Manifold
Power supply with
M12 connector

For the I/O unit part number
mounted, refer to page 2087.

- Digital Input Unit
- Digital Output Unit
- Digital Input/Output Unit
- Analog Input Unit
- Analog Output Unit
- Analog Input/Output Unit

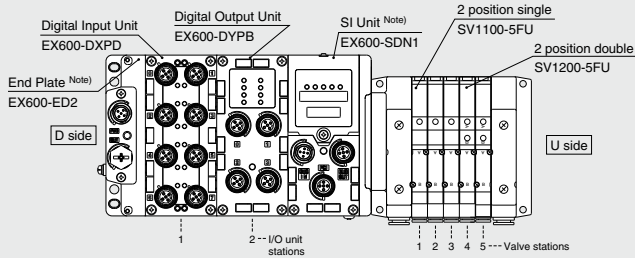

Serial transmission kit

- SS5V1-W10S6Q2N2D-05B-C6 1 set **Manifold base part number**
- * SV1100-5FU 3 sets **Valve part number (Stations 1 to 3)**
 - * SV1200-5FU 2 sets **Valve part number (Stations 4 to 5)**
 - * EX600-DXPD 1 set **I/O unit part number (Station 1)**
 - * EX600-DYPB 1 set **I/O unit part number (Station 2)**

The asterisk denotes the symbol for assembly.
Prefix it to the part nos. of the solenoid valve, etc.

Enter in order starting from the first station on the D side.
When entry of part numbers becomes complicated, indicate with the manifold specification sheet.

Enter in order starting from the first station on the D side.
When entry of part numbers becomes complicated, indicate with the manifold specification sheet.

Note) Do not enter the SI Unit part number and the End Plate part number together.

How to Order Valves

SV 1 1 00 [] [] - 5 F U [] - []

Series

1	SV1000
2	SV2000
3	SV3000

Type of actuation

1	2 position single solenoid
2	2 position double solenoid
3	3 position closed center
4	3 position exhaust center
5	3 position pressure center
A	4 position dual 3 port valve: N.C./N.C.
B	4 position dual 3 port valve: N.O./N.O.
C	4 position dual 3 port valve: N.C./N.O.

* 4 position dual 3 port valves are applicable to the SV1000/2000 series only.

Pilot specifications

NII	Internal pilot
R	External pilot

* External pilot specification is not available for 4 position dual 3 port valves.

Back pressure check valve

NII	None
K	Built-in

- * Built-in back pressure check valve type is applicable to the SV1000 series only.
- * The 3 position valve is not available with the back pressure check valve.

Made to Order

NII	—
X90	Fluororubber specification

Manual override

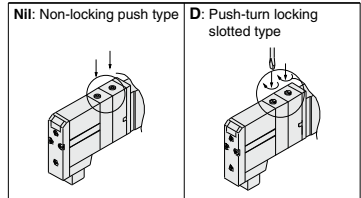

Light/Surge voltage suppressor

U	With light/surge voltage suppressor
R	With surge voltage suppressor

Coil voltage

5	24 VDC
---	--------

- SJ
- SY
- SY
- SV
- SYJ
- SZ
- VF
- VP4
- S0700
- VQ
- VQ4
- VQ5
- VQC
- VQC4
- VQZ
- SQ
- VFS
- VFR
- VQ7

Dimensions: Series SV1000

Power supply with M12 connector

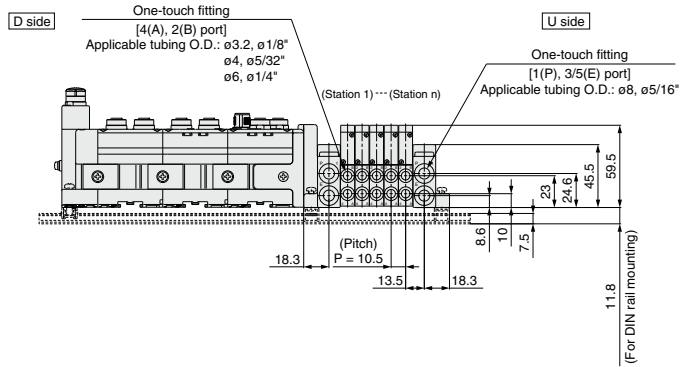
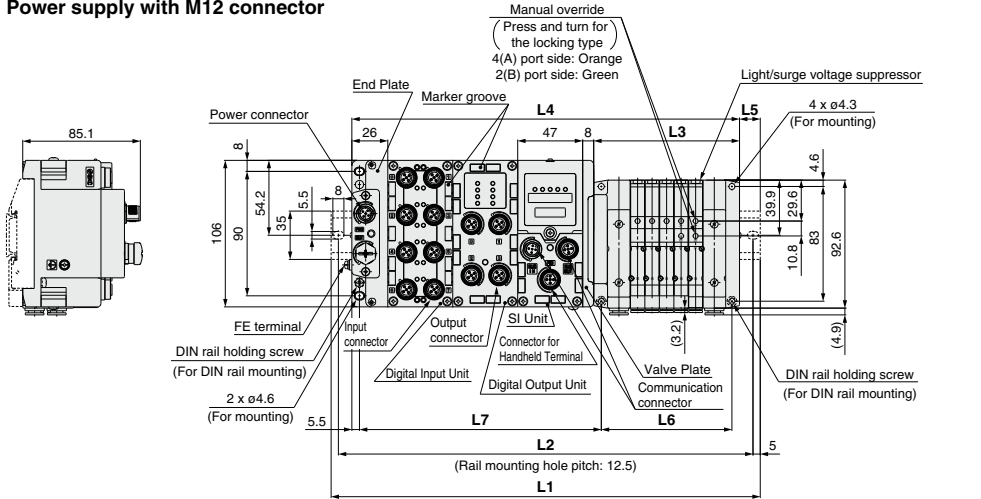

L2 = L1 - 10.5
L3 = 10.5 x n1 + 53
L4 = L3 + 81 + 47 x n2
L5 = (L1 - L4)/2
L6 = 10.5 x n1 + 42
L7 = 47 x n2 + 81

L1: DIN Rail Overall Length

I/O unit stations (n2) \ Valve stations (n1)	2	3	4	5	6	7	8	9	10	11	12	13	14	15	16	17	18	19	20
0	185.5	198	210.5	210.5	223	235.5	248	260.5	273	273	285.5	298	310.5	323	335.5	348	348	360.5	373
1	235.5	248	248	260.5	273	285.5	298	310.5	310.5	323	335.5	348	360.5	373	373	385.5	398	410.5	423
2	273	285.5	298	310.5	323	335.5	335.5	348	360.5	373	385.5	398	410.5	410.5	423	435.5	448	460.5	473
3	323	335.5	348	360.5	373	373	385.5	398	410.5	423	435.5	435.5	448	460.5	473	485.5	498	498	510.5
4	373	385.5	398	398	410.5	423	435.5	448	460.5	473	473	485.5	498	510.5	523	535.5	535.5	548	560.5
5	423	435.5	435.5	448	460.5	473	485.5	498	498	510.5	523	535.5	548	560.5	560.5	573	585.5	598	610.5
6	460.5	473	485.5	498	510.5	523	535.5	535.5	548	560.5	573	585.5	598	598	610.5	623	635.5	648	660.5
7	510.5	523	535.5	548	560.5	560.5	573	585.5	598	610.5	623	623	635.5	648	660.5	673	685.5	698	698
8	560.5	573	585.5	598	598	610.5	623	635.5	648	660.5	660.5	673	685.5	698	710.5	723	723	735.5	748
9	610.5	623	623	635.5	648	660.5	673	685.5	685.5	698	710.5	723	735.5	748	760.5	760.5	773	785.5	798

Dimensions: Series SV1000

Power supply with 7/8 inch connector

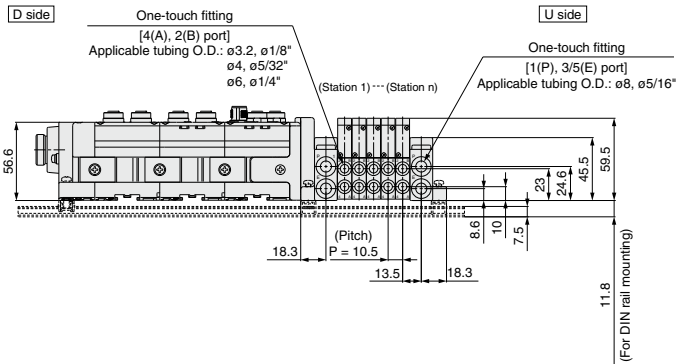
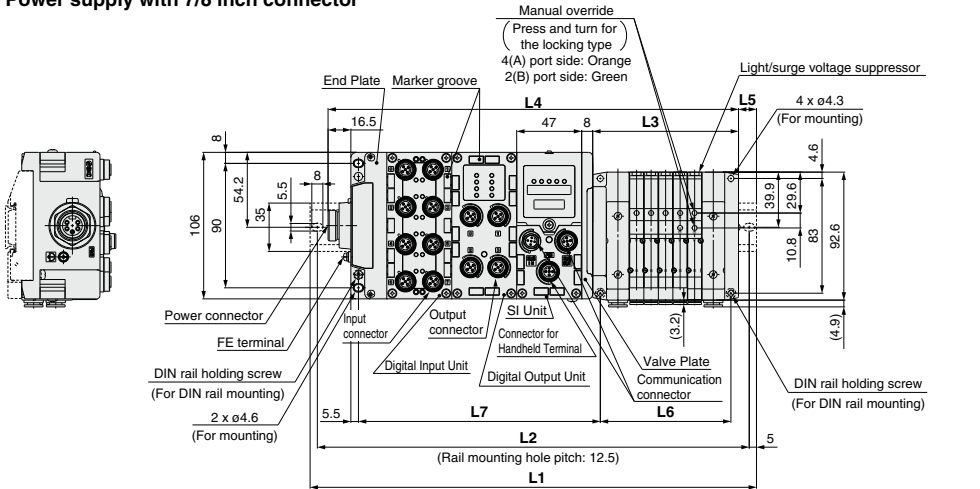

- L2 = L1 - 10.5
- L3 = 10.5 x n1 + 53
- L4 = L3 + 97.5 + 47 x n2
- L5 = (L1 - L4)/2
- L6 = 10.5 x n1 + 42
- L7 = 47 x n2 + 81

L1: DIN Rail Overall Length

I/O unit stations (n2) \ Valve stations (n1)	2	3	4	5	6	7	8	9	10	11	12	13	14	15	16	17	18	19	20
0	198	210.5	223	235.5	248	248	260.5	273	285.5	298	310.5	310.5	323	335.5	348	360.5	373	385.5	385.5
1	248	260.5	273	285.5	285.5	298	310.5	323	335.5	348	360.5	373	385.5	398	410.5	410.5	423	435.5	435.5
2	298	310.5	310.5	323	335.5	348	360.5	373	373	385.5	398	410.5	423	435.5	448	448	460.5	473	485.5
3	348	348	360.5	373	385.5	398	410.5	410.5	423	435.5	448	460.5	473	473	485.5	498	510.5	523	535.5
4	385.5	398	410.5	423	435.5	435.5	448	460.5	473	485.5	498	510.5	510.5	523	535.5	548	560.5	573	573
5	435.5	448	460.5	473	473	485.5	498	510.5	523	535.5	535.5	548	560.5	573	585.5	598	598	610.5	623
6	485.5	498	498	510.5	523	535.5	548	560.5	573	573	585.5	598	610.5	623	635.5	635.5	648	660.5	673
7	535.5	535.5	548	560.5	573	585.5	598	598	610.5	623	635.5	648	660.5	660.5	673	685.5	698	710.5	723
8	573	585.5	598	610.5	623	635.5	635.5	648	660.5	673	685.5	698	698	710.5	723	735.5	748	760.5	760.5
9	623	635.5	648	660.5	660.5	673	685.5	698	710.5	723	723	735.5	748	760.5	773	785.5	798	798	810.5

- SV
- SVJ
- SZ
- VF
- VP4
- S0700
- VQ
- VQ4
- VQ5
- VQC
- VQC4
- VQZ
- SQ
- VFS
- VFR
- VQ7

Dimensions: Series SV2000

Power supply with M12 connector

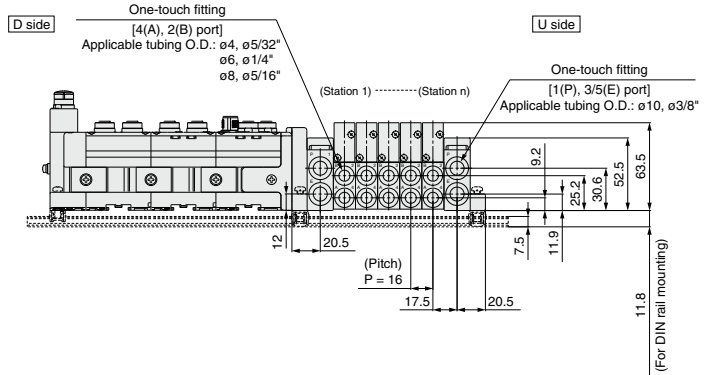
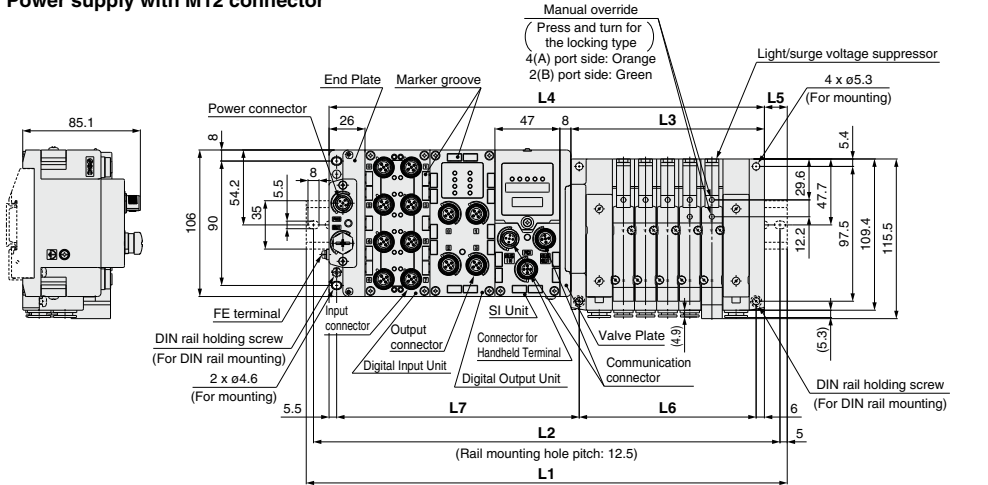

L2 = L1 - 10.5
L3 = 16 x n1 + 60
L4 = L3 + 81 + 47 x n2
L5 = (L1 - L4) / 2
L6 = 16 x n1 + 48
L7 = 47 x n2 + 81.5

L1: DIN Rail Overall Length

I/O unit stations (n2) \ Valve stations (n1)	2	3	4	5	6	7	8	9	10	11	12	13	14	15	16	17	18	19	20
0	198	223	235.5	248	260.5	285.5	298	310.5	335.5	348	360.5	373	398	410.5	423	448	460.5	473	485.5
1	248	260.5	285.5	298	310.5	335.5	348	360.5	373	398	410.5	423	435.5	460.5	473	485.5	510.5	523	535.5
2	298	310.5	323	348	360.5	373	398	410.5	423	435.5	460.5	473	485.5	510.5	523	535.5	548	573	585.5
3	348	360.5	373	385.5	410.5	423	435.5	460.5	473	485.5	498	523	535.5	548	573	585.5	598	610.5	635.5
4	385.5	410.5	423	435.5	460.5	473	485.5	498	523	535.5	548	560.5	585.5	598	610.5	635.5	648	660.5	673
5	435.5	448	473	485.5	498	523	535.5	548	560.5	585.5	598	610.5	635.5	648	660.5	673	698	710.5	723
6	485.5	498	510.5	535.5	548	560.5	585.5	598	610.5	623	648	660.5	673	698	710.5	723	735.5	760.5	773
7	535.5	548	560.5	585.5	598	610.5	623	648	660.5	673	685.5	710.5	723	735.5	760.5	773	785.5	798	823
8	573	598	610.5	623	648	660.5	673	685.5	710.5	723	735.5	760.5	773	785.5	798	823	835.5	848	860.5
9	623	635.5	660.5	673	685.5	710.5	723	735.5	748	773	785.5	798	823	835.5	848	860.5	885.5	898	910.5

Dimensions: Series SV2000

Power supply with 7/8 inch connector

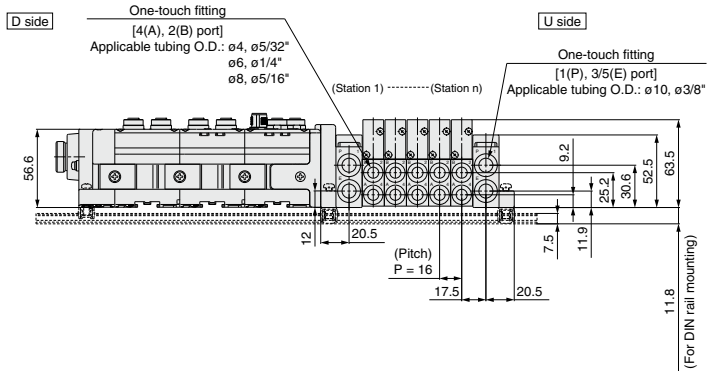
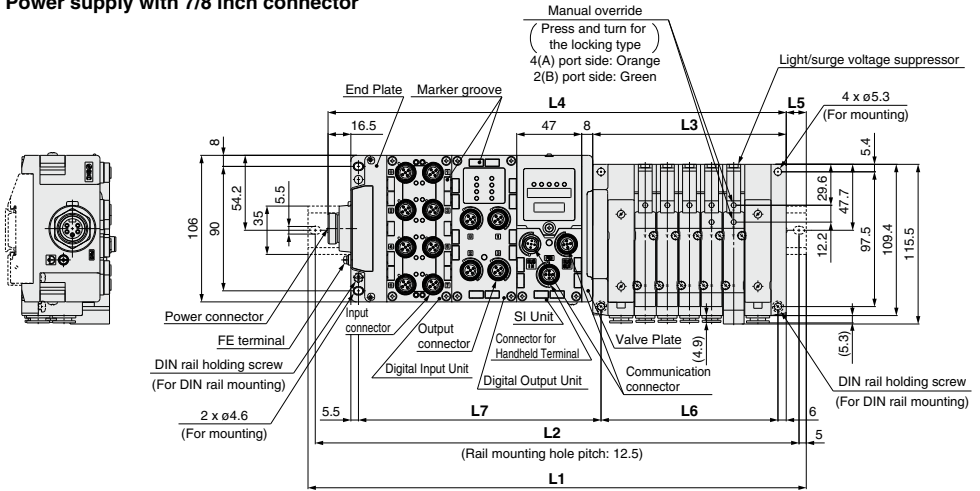

L2 = L1 - 10.5
L3 = 16 x n1 + 60
L4 = L3 + 97.5 + 47 x n2
L5 = (L1 - L4)/2
L6 = 16 x n1 + 48
L7 = 47 x n2 + 81.5

L1: DIN Rail Overall Length

I/O unit stations (n2) \ Valve stations (n1)	2	3	4	5	6	7	8	9	10	11	12	13	14	15	16	17	18	19	20
0	223	235.5	248	273	285.5	298	310.5	335.5	348	360.5	373	398	410.5	423	448	460.5	473	485.5	510.5
1	260.5	285.5	298	310.5	335.5	348	360.5	373	398	410.5	423	448	460.5	473	485.5	510.5	523	535.5	548
2	310.5	323	348	360.5	373	398	410.5	423	435.5	460.5	473	485.5	510.5	523	535.5	548	573	585.5	598
3	360.5	373	398	410.5	423	435.5	460.5	473	485.5	498	523	535.5	548	573	585.5	598	610.5	635.5	648
4	410.5	423	435.5	460.5	473	485.5	498	523	535.5	548	573	585.5	598	610.5	635.5	648	660.5	673	698
5	448	473	485.5	498	523	535.5	548	560.5	585.5	598	610.5	635.5	648	660.5	673	698	710.5	723	748
6	498	523	535.5	548	560.5	585.5	598	610.5	623	648	660.5	673	698	710.5	723	735.5	760.5	773	785.5
7	548	560.5	585.5	598	610.5	623	648	660.5	673	698	710.5	723	735.5	760.5	773	785.5	798	823	835.5
8	598	610.5	623	648	660.5	673	685.5	710.5	723	735.5	760.5	773	785.5	798	823	835.5	848	873	885.5
9	648	660.5	673	685.5	710.5	723	735.5	748	773	785.5	798	823	835.5	848	860.5	885.5	898	910.5	935.5

- SV
- SVJ
- SZ
- VF
- VP4
- S0700
- VQ
- VQ4
- VQ5
- VQC
- VQC4
- VQZ
- SQ
- VFS
- VFR
- VQ7

Series SV

Dimensions: Series SV3000

Power supply with M12 connector

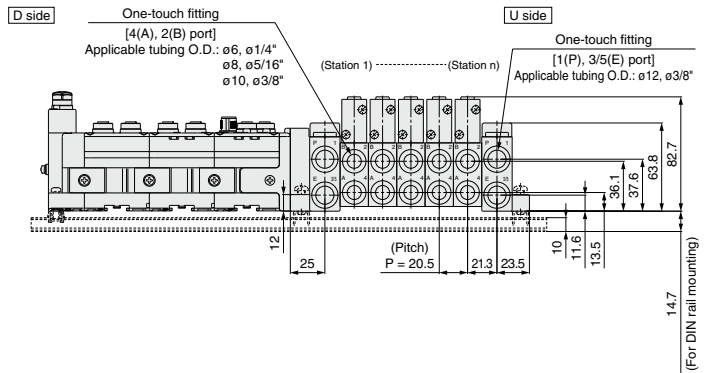
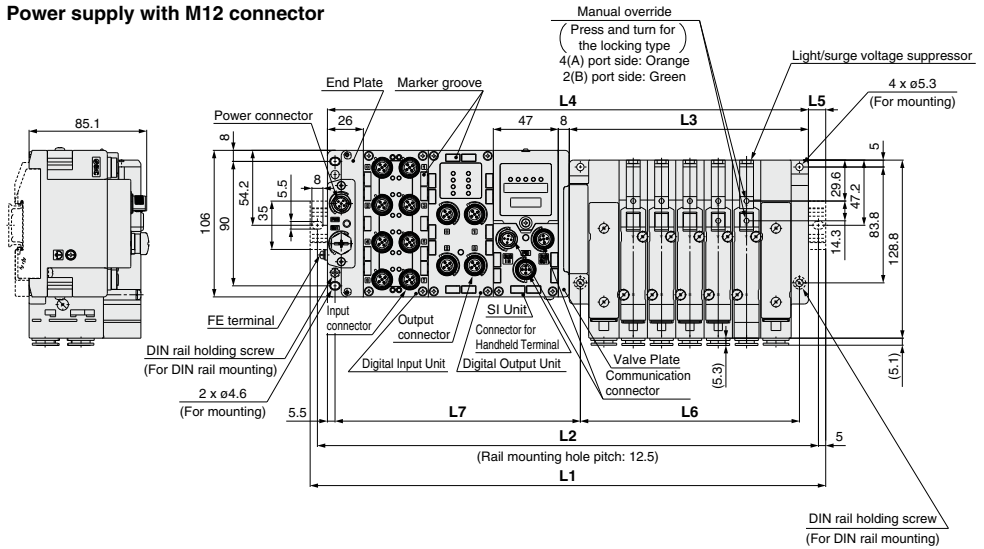

$L2 = L1 - 10.5$
 $L3 = 20.5 \times n1 + 70.5$
 $L4 = L3 + 81 + 47 \times n2$
 $L5 = (L1 - L4)/2$
 $L6 = 20.5 \times n1 + 56$
 $L7 = 47 \times n2 + 83.5$

L1: DIN Rail Overall Length

I/O unit stations (n2) \ Valve stations (n1)	2	3	4	5	6	7	8	9	10	11	12	13	14	15	16	17	18	19	20
0	223	248	260.5	285.5	298	323	348	360.5	385.5	410.5	423	448	473	485.5	510.5	535.5	548	573	585.5
1	273	285.5	310.5	335.5	348	373	398	410.5	435.5	448	473	498	510.5	535.5	560.5	573	598	623	635.5
2	310.5	335.5	360.5	373	398	423	435.5	460.5	485.5	498	523	535.5	560.5	585.5	598	623	648	660.5	685.5
3	360.5	385.5	398	423	448	460.5	485.5	510.5	523	548	573	585.5	610.5	635.5	648	673	685.5	710.5	735.5
4	410.5	435.5	448	473	498	510.5	535.5	548	573	598	610.5	635.5	660.5	673	698	723	735.5	760.5	773
5	460.5	473	498	523	535.5	560.5	585.5	598	623	635.5	660.5	685.5	698	723	748	760.5	785.5	810.5	823
6	498	523	548	560.5	585.5	610.5	623	648	673	685.5	710.5	735.5	748	773	785.5	810.5	835.5	848	873
7	548	573	598	610.5	635.5	648	673	698	710.5	735.5	760.5	773	798	823	835.5	860.5	873	898	923
8	598	623	635.5	660.5	685.5	698	723	735.5	760.5	785.5	798	823	848	860.5	885.5	910.5	923	948	973
9	648	660.5	685.5	710.5	723	748	773	785.5	810.5	835.5	848	873	885.5	910.5	935.5	948	973	—	—

Dimensions: Series SV3000

Power supply with 7/8 inch connector

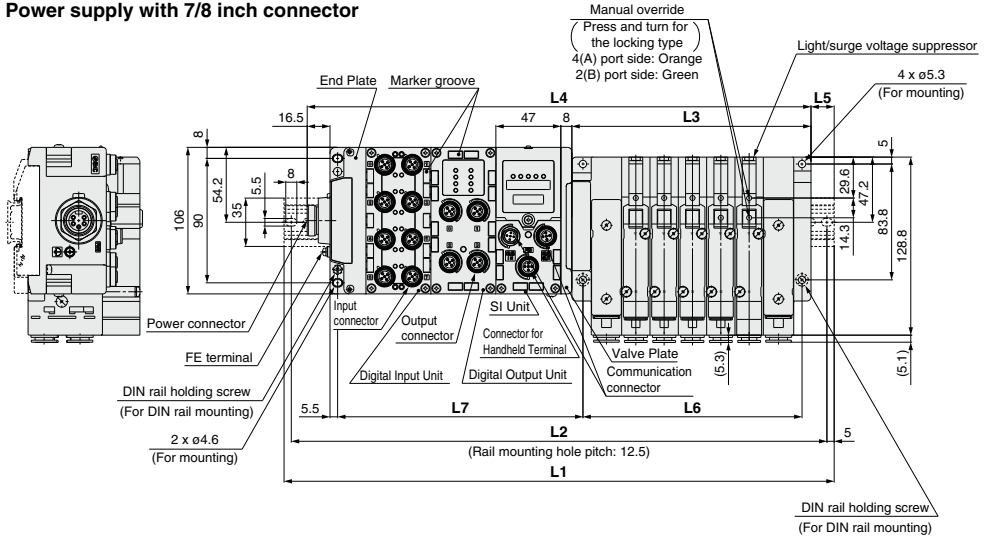

- L2 = L1 - 10.5
- L3 = 20.5 x n1 + 70.5
- L4 = L3 + 97.5 + 47 x n2
- L5 = (L1 - L4)/2
- L6 = 20.5 x n1 + 56
- L7 = 47 x n2 + 83.5

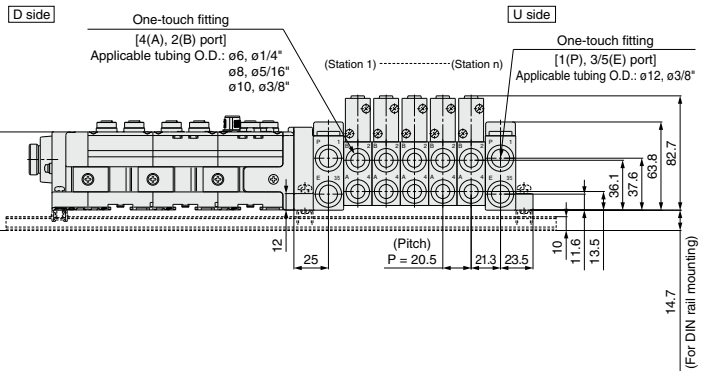

L1: DIN Rail Overall Length

I/O unit stations (n2) \ Valve stations (n1)	2	3	4	5	6	7	8	9	10	11	12	13	14	15	16	17	18	19	20
0	235.5	260.5	285.5	298	323	335.5	360.5	385.5	398	423	448	460.5	485.5	510.5	523	548	560.5	585.5	610.5
1	285.5	310.5	323	348	373	385.5	410.5	423	448	473	485.5	510.5	535.5	548	573	598	610.5	635.5	660.5
2	335.5	348	373	398	410.5	435.5	460.5	473	498	523	535.5	560.5	573	598	623	635.5	660.5	685.5	698
3	385.5	398	423	435.5	460.5	485.5	498	523	548	560.5	585.5	610.5	623	648	660.5	685.5	710.5	723	748
4	423	448	473	485.5	510.5	523	548	573	585.5	610.5	635.5	648	673	698	710.5	735.5	760.5	773	798
5	473	498	510.5	535.5	560.5	573	598	623	635.5	660.5	673	698	723	735.5	760.5	785.5	798	823	848
6	523	535.5	560.5	585.5	598	623	648	660.5	685.5	710.5	723	748	760.5	785.5	810.5	823	848	873	885.5
7	573	585.5	610.5	623	648	673	685.5	710.5	735.5	748	773	798	810.5	835.5	860.5	873	898	910.5	935.5
8	610.5	635.5	660.5	673	698	723	735.5	760.5	773	798	823	835.5	860.5	885.5	898	923	948	960.5	985.5
9	660.5	685.5	698	723	748	760.5	785.5	810.5	823	848	860.5	885.5	910.5	923	948	973	985.5	—	—

Integrated-type (For Output) Serial Transmission System

Series EX260

IP67 (partly IP40) compliant

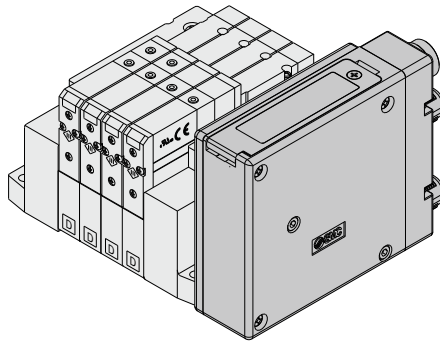

Tie-rod base

Applicable series **Tie-rod base manifold**
SV1000/SV2000/SV3000

• Number of outputs points: 16, 32 points each

SJ
SY
SY
SV
SYJ
SZ
VF
VP4
S0700
VQ
VQ4
VQ5
VQC
VQC4
VQZ
SQ
VFS
VFR
VQ7

Tie-rod Base: EX260 Integrated-type (For Output) Serial Transmission System

Series SV



How to Order Manifold

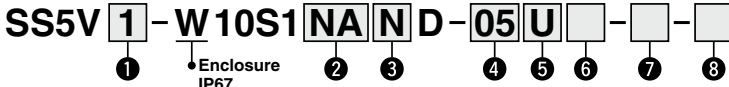

① Series

1	SV1000
2	SV2000
3	SV3000

② SI unit specifications

Symbol	Protocol	Number of outputs	Communication connector
QA	DeviceNet™	32	M12
QB		16	
NA		32	
NB		16	
NC	PROFIBUS DP	32	M12
ND		16	
VA	CC-Link	32	M12
VB		16	
DA	EtherCAT	32	M12
DB		16	
FA	PROFINET	32	M12
FB		16	
EA	EtherNet/IP™	32	M12
EB		16	

Note 1) IP40 for the D-sub applicable communication connector specification. (The manifold part number is "SS5V□-10S1NC/ND□".)

Note 2) For SI unit part number, refer to the table below.

③ SI unit output polarity

Nii	Positive common
N	Negative common

Note) Without SI unit, the symbol is nil.

⑦ A, B port size (Metric size)

Symbol	A, B port	P, E port	Applicable series
C3	ø3.2 One-touch fitting	ø8 One-touch fitting	SV1000
C4	ø4 One-touch fitting		
C6	ø6 One-touch fitting	ø10 One-touch fitting	SV2000
C4	ø4 One-touch fitting		
C6	ø6 One-touch fitting		
C8	ø8 One-touch fitting		
C6	ø6 One-touch fitting	ø12 One-touch fitting	SV3000
C8	ø8 One-touch fitting		
M10	ø10 One-touch fitting		

A, B ports mixed

* In the case of mixed specifications (M), indicate separately on the manifold specification sheet.

* The port sizes of X, PE ports for external pilot specifications (R, Rs) are ø4 (millimeters) or ø5/32" (inches) for the Series SV1000/2000, and ø6 (millimeters) or ø1/4" (inches) for the Series SV3000.

EX260 SI unit part no.

Symbol	Protocol	Number of outputs	Communication connector	SI unit part no.	
				+COM.	-COM.
QA	DeviceNet™	32	M12	EX260-SDN2	EX260-SDN1
QB		16		EX260-SDN4	EX260-SDN3
NA		32		EX260-SPR2	EX260-SPR1
NB		16		EX260-SPR4	EX260-SPR3
NC	PROFIBUS DP	32	M12	EX260-SPR6	EX260-SPR5
ND		16		EX260-SPR8	EX260-SPR7
VA	CC-Link	32	M12	EX260-SMJ2	EX260-SMJ1
VB		16		EX260-SMJ4	EX260-SMJ3

④ Valve stations

In case of the 32 Outputs SI unit

Symbol	Stations	Note
02	2 stations	Note
⋮	⋮	⋮
16	16 stations	Double wiring Note 1)
⋮	⋮	⋮
02	2 stations	Specified layout Note 2)
⋮	⋮	⋮
20	20 stations	(Available up to 32 solenoids)

In case of the 16 Outputs SI unit

Symbol	Stations	Note
02	2 stations	Note
⋮	⋮	⋮
08	8 stations	Double wiring Note 1)
⋮	⋮	⋮
02	2 stations	Specified layout Note 2)
⋮	⋮	⋮
16	16 stations	(Available up to 16 solenoids)

Note 1) Double wiring: single, double, 3-position and 4-position solenoid valves can be used on all manifold stations. Use of a single solenoid will result in an unused control signal. If this is not desired, order with a specified layout.

Note 2) Specified layout: Indicate the wiring specifications with the manifold specification sheet. (Note that double, 3-position and 4-position valves cannot be used where single solenoid wiring has been specified.)

⑤ P, E port location

U	U side (2 to 10 stations)
D	D side (2 to 10 stations)
B	Both sides (2 to 20 stations)

⑥ SUP/EXH block assembly specifications

Nii	Internal pilot
S Note)	Internal pilot/Built-in silencer
R	External pilot
RS Note)	External pilot/Built-in silencer

Note) When the built-in silencer type is used, keep the air outlet from coming in direct contact with water or other liquids.

⑧ Mounting

Nii	Direct mounting
D	DIN rail mounting (With DIN rail)
D0	DIN rail mounting (Without DIN rail)
D3	For 3 stations
⋮	⋮
D20	For 20 stations

When a longer DIN rail is desired than the specified stations. (Specify a longer rail than the standard length.)

A, B port size (Inch size)

Symbol	A, B port	P, E port	Applicable series
N1	ø1/8" One-touch fitting	ø5/16" One-touch fitting	SV1000
N3	ø5/32" One-touch fitting		
N7	ø1/4" One-touch fitting		
N3	ø5/32" One-touch fitting	ø3/8" One-touch fitting	SV2000
N7	ø1/4" One-touch fitting		
N9	ø5/16" One-touch fitting		
N7	ø1/4" One-touch fitting		
N9	ø5/16" One-touch fitting	ø3/8" One-touch fitting	SV3000
M11	ø3/8" One-touch fitting		

A, B ports mixed

EX260 SI unit part no.

Symbol	Protocol	Number of outputs	Communication connector	SI unit part no.	
				+COM.	-COM.
DA	EtherCAT	32	M12	EX260-SEC2	EX260-SEC1
DB		16		EX260-SEC4	EX260-SEC3
FA	PROFINET	32	M12	EX260-SPN2	EX260-SPN1
FB		16		EX260-SPN4	EX260-SPN3
EA	EtherNet/IP™	32	M12	EX260-SEN2	EX260-SEN1
EB		16		EX260-SEN4	EX260-SEN3

How to Order Manifold Assembly

Example (SV1000)

Manifold
 SS5V1-W10S1NAND-04B-C6 (1 set)

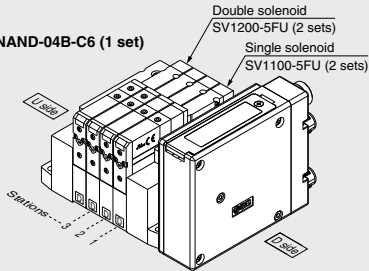

SS5V1-W10S1NAND-04B-C6 1 set (Manifold part no.)
 *SV1100-5FU 2 sets (Single solenoid part no.)
 *SV1200-5FU 2 sets (Double solenoid part no.)

How to Order Valves

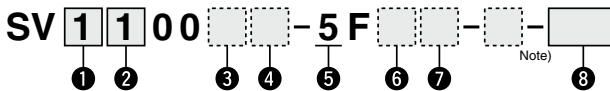

1 Series

1	SV1000
2	SV2000
3	SV3000

2 Type of actuation

1	2-position single
2	2-position double
3	3-position closed center
4	3-position exhaust center
5	3-position pressure center
A	4-position dual 3-port valve: N.C./N.C.
B	4-position dual 3-port valve: N.O./N.O.
C	4-position dual 3-port valve: N.C./N.O.

* 4-position dual 3-port valves are applicable to the Series SV1000 and SV2000 only.

3 Pilot type

NII	Internal pilot
R	External pilot

* External pilot specifications is not available for 4-position dual 3-port valves.

4 Back pressure check valve

NII	None
K	Built-in

* Built-in back pressure check valve type is applicable to the Series SV1000 only.
 * Back pressure check valve is not available for 3-position valve.

Note) Refer to Specific Product Precautions 2 on page 648.

5 Rated voltage

5	24 VDC
---	--------

6 Light/Surge voltage suppressor

U	With light/surge voltage suppressor
R	With surge voltage suppressor

7 Manual override

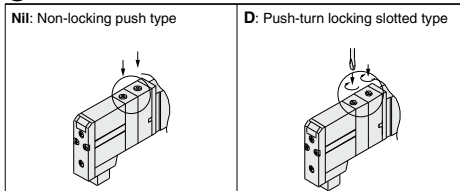

Note) Available with manifold block for station additions. Refer to page 631.

8 Made to Order

NII	—
X90	Main valve fluororubber (Refer to page 646.)

• Refer to page 2068 for the dimensions of single SI unit.
 • Refer to the technical operation manual for details of SI unit.

- SV
- SVJ
- SZ
- VF
- VP4
- S0700
- VQ
- VQ4
- VQ5
- VQC
- VQC4
- VQZ
- SQ
- VFS
- VFR
- VQ7

Series SV

Dimensions: Series SV1000 for EX260 Integrated-type (For Output) Serial Transmission System

● Tie-rod base manifold: SS5V1-W10S1□□D-**Stations** $\frac{U}{D}$ (S, R, RS)- $\frac{C3, N1}{C4, N3}$ (-D)
 $\frac{C6, N7}{C6, N7}$

- When P, E port outlets are indicated on the U side or D side, the P, E ports on the opposite side are plugged.
- External pilot port positions and silencer discharge port positions are the same as P, E port outlet positions.

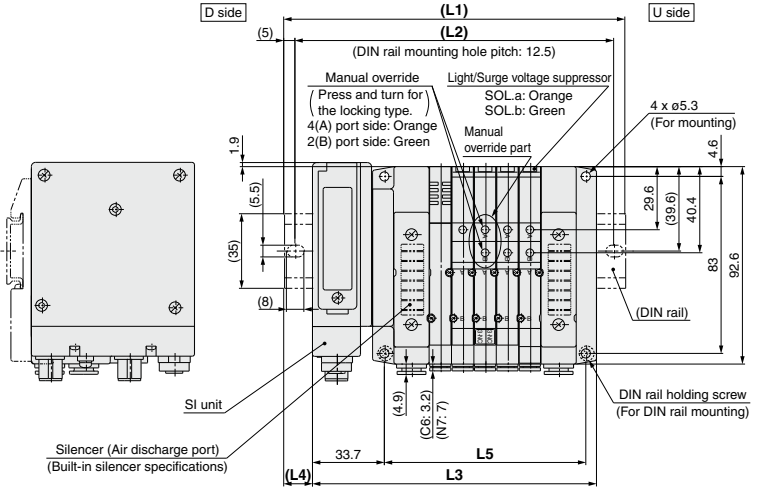

[Communication connector D-sub]

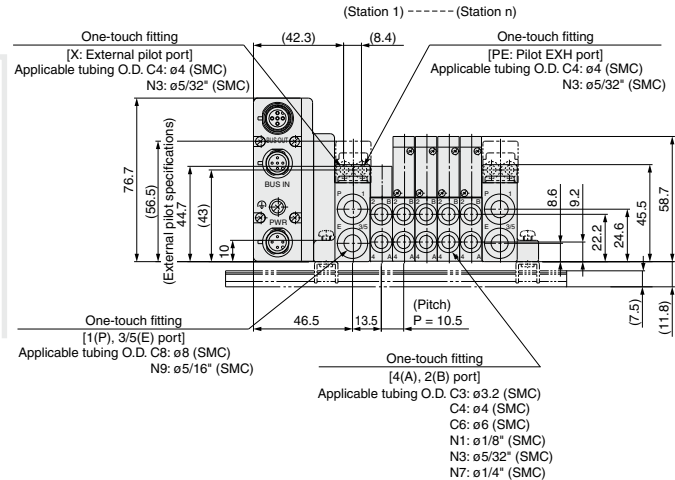
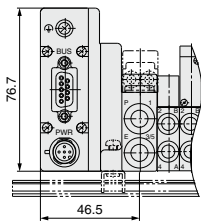

L: DIN Rail Overall Length

n: Stations

L	n	2	3	4	5	6	7	8	9	10	11	12	13	14	15	16	17	18	19	20
L1		135.5	148	148	160.5	173	185.5	198	210.5	210.5	223	235.5	248	260.5	273	273	285.5	298	310.5	323
L2		125	137.5	137.5	150	162.5	175	187.5	200	200	212.5	225	237.5	250	262.5	262.5	275	287.5	300	312.5
L3		102.2	112.7	123.2	133.7	144.2	154.7	165.2	175.7	186.2	196.7	207.2	217.7	228.2	238.7	249.2	259.7	270.2	280.7	291.2
L4		16.5	17.5	12.5	13.5	14.5	15.5	16.5	17.5	12	13	14	15	16	17	12	13	14	15	16
L5		63	73.5	84	94.5	105	115.5	126	136.5	147	157.5	168	178.5	189	199.5	210	220.5	231	241.5	252

Tie-rod Base: EX260 Integrated-type (For Output) Serial Transmission System *Series SV*

Dimensions: Series SV2000 for EX260 Integrated-type (For Output) Serial Transmission System

● Tie-rod base manifold: SS5V2-W10S1□□D-**Stations** $\frac{U}{D}$ (S, R, RS)- $\frac{C3, N3}{C6, N6}$ (-D)

- When P, E port outlets are indicated on the U side or D side, the P, E ports on the opposite side are plugged.
- External pilot port positions and silencer discharge port positions are the same as P, E port outlet positions.

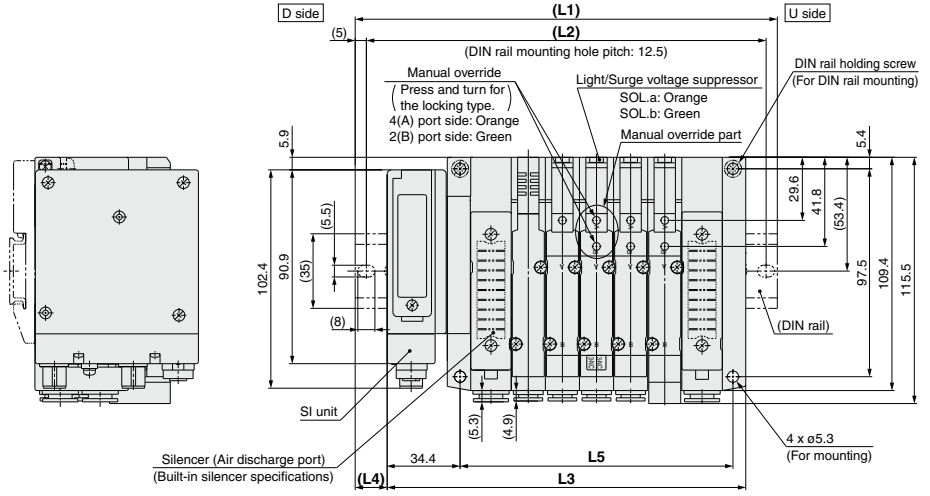

[Communication connector D-sub]

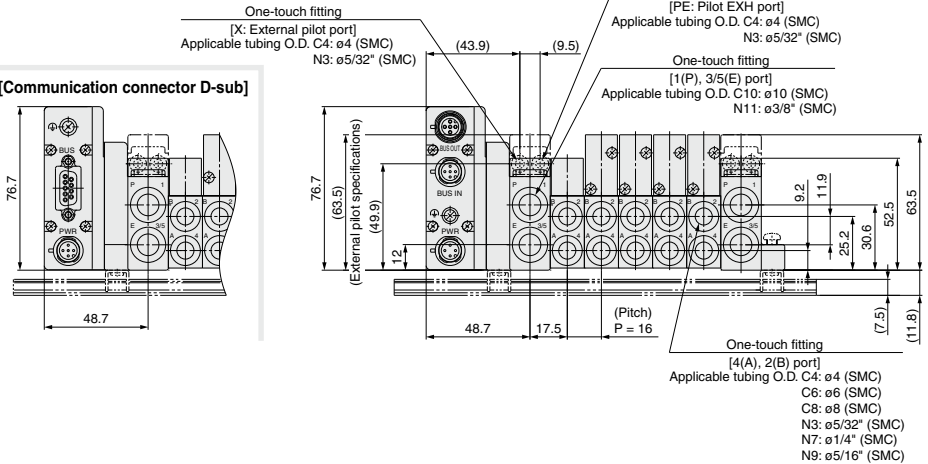

L: DIN Rail Overall Length

L	n: Stations																			
	2	3	4	5	6	7	8	9	10	11	12	13	14	15	16	17	18	19	20	
L1	148	160.5	185.5	198	210.5	235.5	248	260.5	273	298	310.5	323	335.5	360.5	373	385.5	410.5	423	435.5	
L2	137.5	150	175	187.5	200	225	237.5	250	262.5	287.5	300	312.5	325	350	362.5	375	400	412.5	425	
L3	120.2	136.2	152.2	168.2	184.2	200.2	216.2	232.2	248.2	264.2	280.2	296.2	312.2	328.2	344.2	360.2	376.2	392.2	408.2	
L4	14	12	16.5	15	13	17.5	16	14	12.5	17	15	13.5	11.5	16	14.5	12.5	17	15.5	13.5	
L5	80	96	112	128	144	160	176	192	208	224	240	256	272	288	304	320	336	352	368	

- SJ
- SY
- SY
- SV
- SYJ
- SZ
- VF
- VP4
- S0700
- VQ
- VQ4
- VQ5
- VQC
- VQC4
- VQZ
- SQ
- VFS
- VFR
- VQ7

Dimensions: Series SV3000 for EX260 Integrated-type (For Output) Serial Transmission System

● Tie-rod base manifold: SS5V3-W10S1□□□D- $\frac{U}{D}$ Stations (S, R, RS)- $\frac{C6, N7}{C8, N9}$ $\frac{C10, N11}{C12}$ (-D)

- When P, E port outlets are indicated on the U side or D side, the P, E ports on the opposite side are plugged.
- External pilot port positions and silencer discharge port positions are the same as P, E port outlet positions.

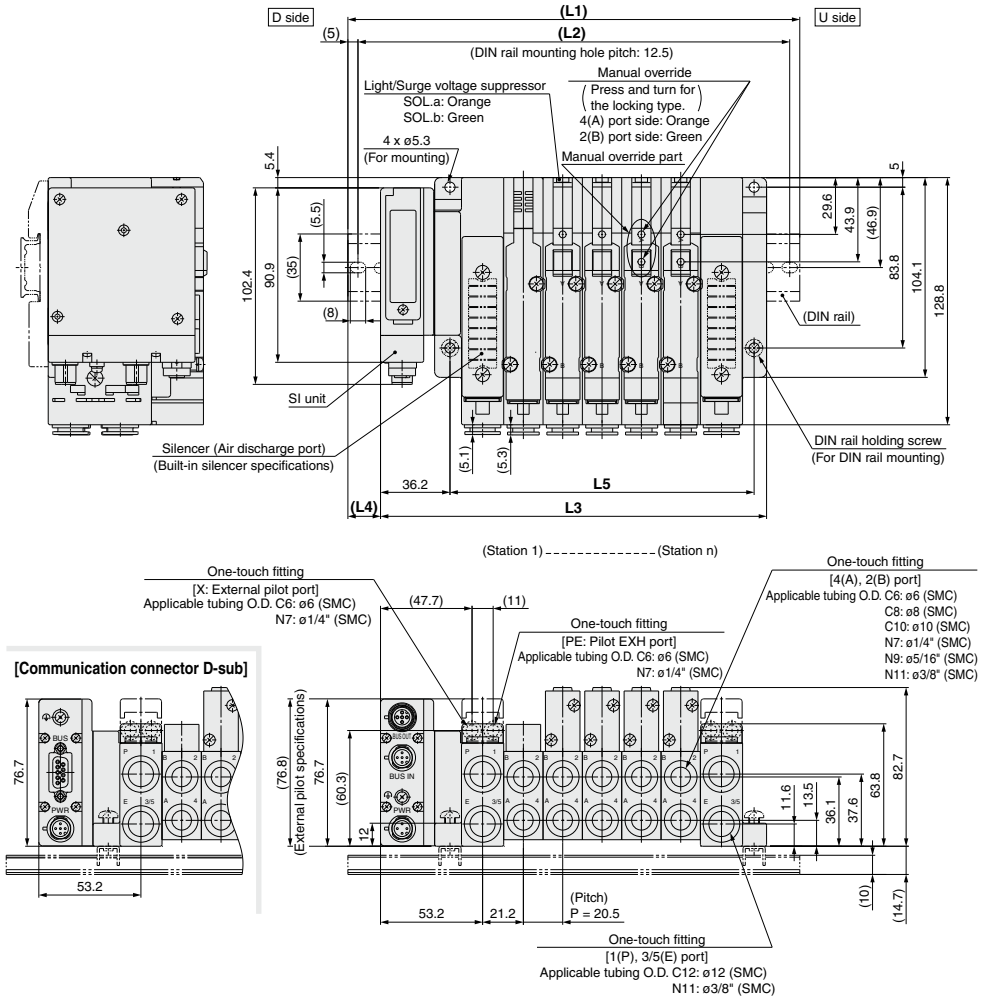

L: DIN Rail Overall Length

L	n: Stations																			
	2	3	4	5	6	7	8	9	10	11	12	13	14	15	16	17	18	19	20	
L1	173	185.5	210.5	235.5	248	273	298	310.5	335.5	348	373	398	410.5	435.5	460.5	473	498	523	535.5	
L2	162.5	175	200	225	237.5	262.5	287.5	300	325	337.5	362.5	387.5	400	425	450	462.5	487.5	512.5	525	
L3	139.7	160.2	180.7	201.2	221.7	242.2	262.7	283.2	303.7	324.2	344.7	365.2	385.7	406.2	426.7	447.2	467.7	488.2	508.7	
L4	16.5	12.5	15	17	13	15.5	17.5	13.5	16	12	14	16.5	12.5	14.5	17	13	15	17.5	13.5	
L5	97	117.5	138	158.5	179	199.5	220	240.5	261	281.5	302	322.5	343	363.5	384	404.5	425	445.5	466	

Integrated-type (For Output) Serial Transmission System

Series EX126

IP67 compliant

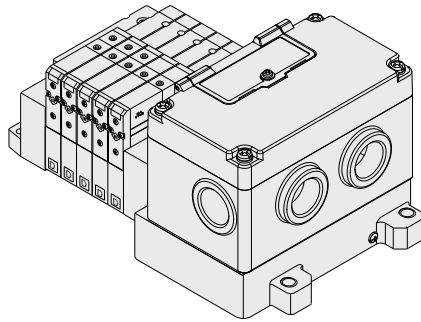

Applicable series **Tie-rod base manifold**
SV1000/SV2000/SV3000

• Number of outputs points: 16 points

SJ
SY
SY
SV
SYJ
SZ
VF
VP4
S0700
VQ
VQ4
VQ5
VQC
VQC4
VQZ
SQ
VFS
VFR
VQ7

EX126 Integrated-type (For Output) Serial Transmission System

Series SV



How to Order

● Tie-rod base

SS5V **1** - W 10S4 D-05 U - -

Series

1	SV1000
2	SV2000
3	SV3000

Enclosure
IP67 specifications

SI unit

0	Without SI unit and end plate
VW	CC-Link

● When the SI unit is not included, only the terminal block plate is included.

● Mounting

Nil	Direct mounting
D	DIN rail mounting (With DIN rail)
D0*	DIN rail mounting (Without DIN rail)
D3	For 3 stations
:	:
:	:
D16	For 16 stations

* In the case of D0, only DIN rail fittings are attached.

● Valve stations

Symbol	Stations	Note
02	2 stations	Double wiring specifications (1)
:	:	
:	:	
08	8 stations	Specified layout (2) (up to 16 solenoids possible.)
02	2 stations	
:	:	
16	16 stations	

Note 1) Double wiring specifications: Single, double, 3 position and 4 position solenoid valves can be used on all manifold stations. Use of a single solenoid will result in an unused control signal. If this is not desired, order with a specified layout.

Note 2) Specified layout: Indicate wiring specifications on a manifold specificationsheet. (Note that double, 3 and 4 position valves cannot be used where single solenoid wiring has been specified.)

● SUP/EXH block assembly specifications

Nil	Internal pilot
S*	Internal pilot/Built-in silencer
R	External pilot
RS*	External pilot/Built-in silencer

Note) When the built-in silencer type is used, keep the exhaust port from coming in direct contact with water or other liquids.

SI Unit Part No.

Symbol	Protocol type	SI unit part no.
VW	CC-Link	EX126D-SMJ1

Refer to page 2055 and the Operation Manual for the details of the EX126 Integrated-type (For Output) Serial Transmission System. Please download the Operation Manual via our website, <http://www.smwworld.com>.

● P, E port location

U	U side (2 to 10 stations)
D	D side (2 to 10 stations)
B	Both sides (2 to 16 stations)

A, B port size (Metric)

Symbol	A, B port	P, E port	Applicable series
C3	One-touch fitting for ø3.2	One-touch fitting for ø4	SV1000
C4	One-touch fitting for ø4		
C6	One-touch fitting for ø6	One-touch fitting for ø8	SV2000
C4	One-touch fitting for ø4		
C6	One-touch fitting for ø6	One-touch fitting for ø10	SV3000
C8	One-touch fitting for ø8		
C6	One-touch fitting for ø6	One-touch fitting for ø12	SV3000
C8	One-touch fitting for ø8		
C10	One-touch fitting for ø10		
M	A, B ports mixed		

A, B port size (Inch)

Symbol	A, B port	P, E port	Applicable series
N1	One-touch fitting for ø1/8"	One-touch fitting for ø5/16"	SV1000
N3	One-touch fitting for ø5/32"		
N7	One-touch fitting for ø1/4"	One-touch fitting for ø3/8"	SV2000
N3	One-touch fitting for ø5/32"		
N7	One-touch fitting for ø1/4"	One-touch fitting for ø3/8"	SV3000
N9	One-touch fitting for ø5/16"		
N7	One-touch fitting for ø1/4"	One-touch fitting for ø3/8"	SV3000
N9	One-touch fitting for ø5/16"		
N11	One-touch fitting for ø3/8"		
M	A, B ports mixed		

* In the case of mixed specifications (M), indicate separately on the manifold specification sheet.

* Port sizes of X, PE port for external pilot specification (R, RS) are ø4 (metric), ø5/32" (inch) for SV1000/2000 and ø6 (metric) and ø1/4" (inch) for SV3000.

How to Order Manifold Assembly

Ordering example (SV1000)

Manifold

SS5V1-W10S4VVD-05B-C6 (1 set)

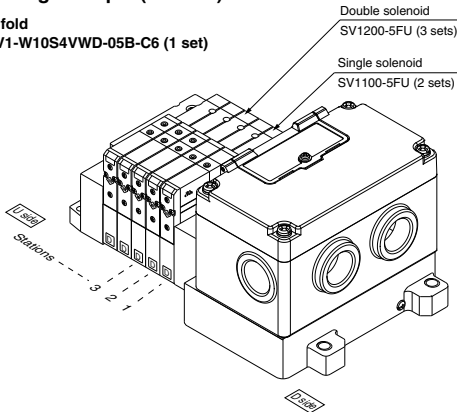

SS5V1-W10S4VVD-05B-C6 1 set (manifold part no.)
 * SV1100-5FU 2 sets (manifold part no.)
 * SV1200-5FU 3 sets (manifold part no.)

How to Order Valve

SV 1 1 0 0 - 5 F - - -

Series

1	SV1000
2	SV2000
3	SV3000

Type of actuation

1	2 position single
2	2 position double
3	3 position closed center
4	3 position exhaust center
5	3 position pressure center
A	4 position dual 3 port valve: N.C./N.C.
B	4 position dual 3 port valve: N.O./N.O.
C	4 position dual 3 port valve: N.C./N.O.

* 4 position dual 3 port valves are applicable to Series SV1000 and SV2000 only.

Pilot type

Nil	Internal pilot
R	External pilot

* External pilot specifications is not available for 4 position dual 3 port valves.

Back pressure check valve

Nil	None
K	Built-in

- * Built-in back pressure check valve type is applicable to series SV1000 only.
- * Back pressure check valve is not available for 3 position valve.

Rated voltage

5	24 VDC
---	--------

Note) Available with manifold block for station additions. Refer to page 631.

Made to Order

Nil	-
X90	Main valve fluororubber (Refer to page 646.)

Manual override

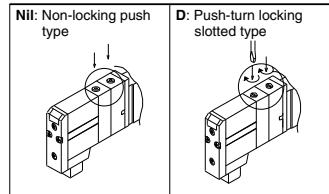

Light/Surge voltage suppressor

U	With light/surge voltage suppressor
R	With surge voltage suppressor

Note) Refer to Specific Product Precautions 2 on page 648.

SV
SVJ
SZ
VF
VP4
S0700
VQ
VQ4
VQ5
VQC
VQC4
VQZ
SQ
VFS
VFR
VQ7

Series SV

Dimensions: Series SV1000 for EX126 Integrated-type (For Output) Serial Transmission System

● Tie-rod base manifold : SS5V1-W10S4 □ D-^UStations₀(S, R, RS)-^{C3, N1, C4, N3, C6, N7}(-D)

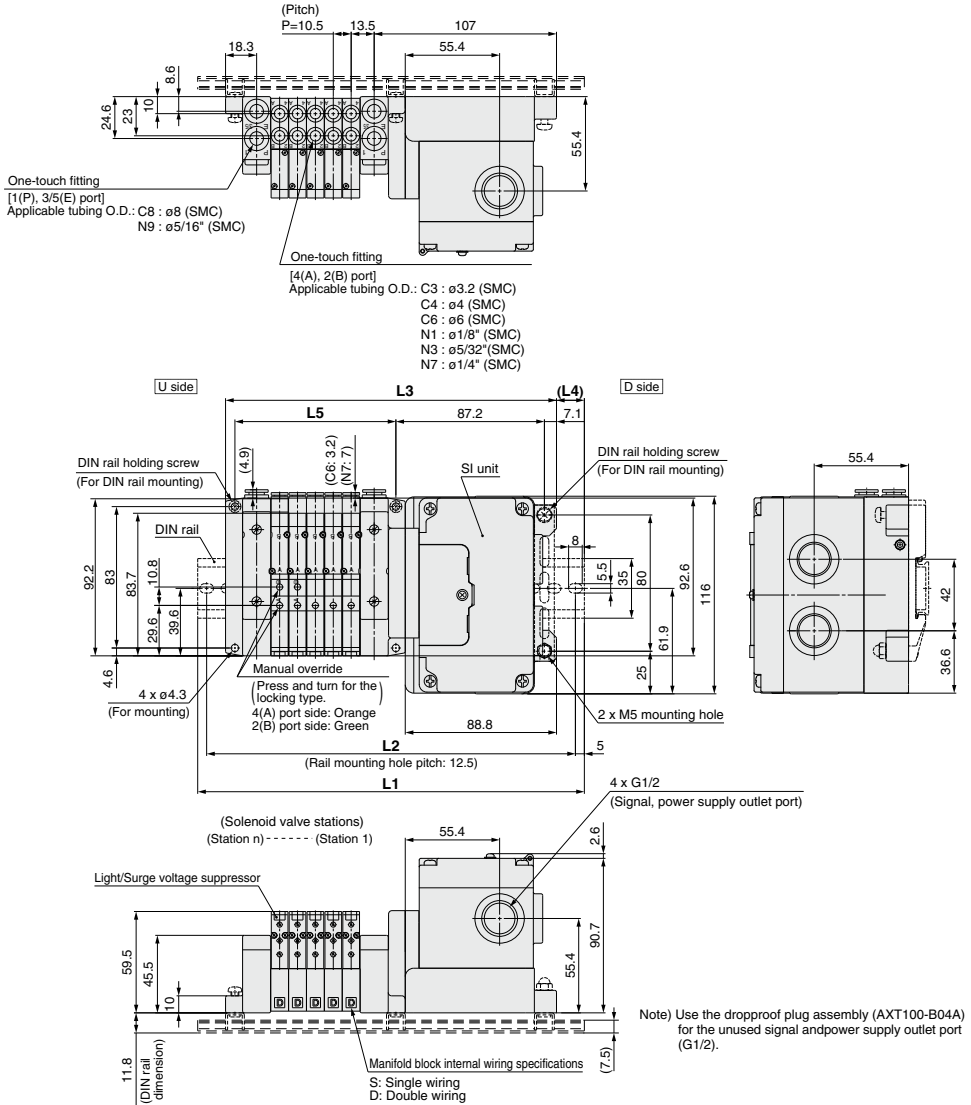

L Dimension

n: Stations

n	2	3	4	5	6	7	8	9	10	11	12	13	14	15	16
L1	198	198	210.5	223	235.5	248	260.5	260.5	273	285.5	298	310.5	323	323	335.5
L2	187.5	187.5	200	212.5	225	237.5	250	250	262.5	275	287.5	300	312.5	312.5	325
L3	162.8	173.3	183.8	194.3	204.8	215.3	225.8	236.3	246.8	257.3	267.8	278.3	288.8	299.3	309.8
L4	17.5	12.5	13.5	14.5	15.5	16.5	17.5	12	13	14	15	16	17	12	13
L5	63	73.5	84	94.5	105	115.5	126	136.5	147	157.5	168	178.5	189	199.5	210

Dimensions: Series SV2000 for EX126 Integrated-type (For Output) Serial Transmission System

● Tie-rod base manifold : SS5V2-W10S4 □ D- Stations $\frac{U}{D}$ (S, R, RS) $\frac{C4, N6}{C6, N7}$ (N7, N9) (-D)

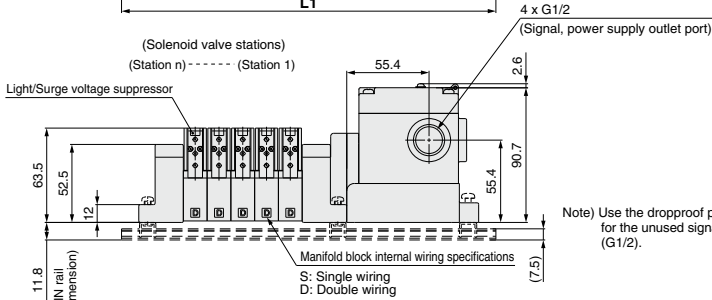
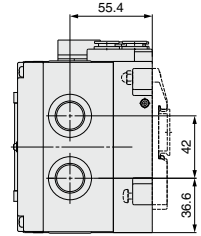
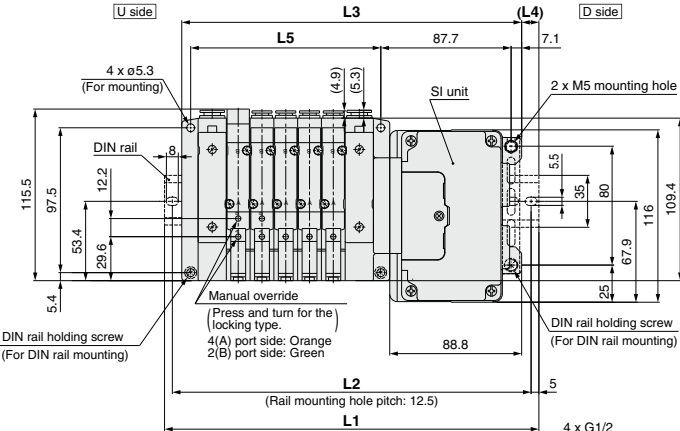
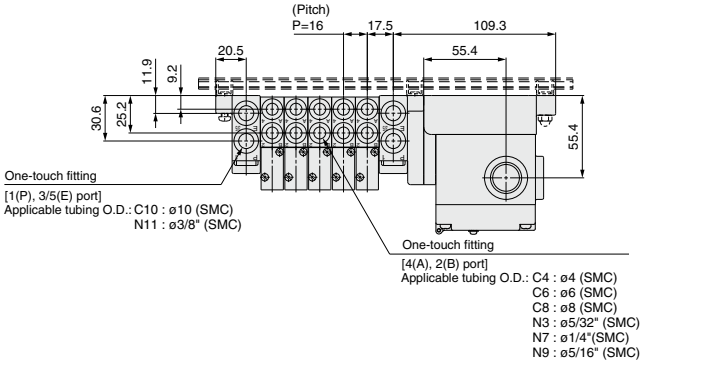

Note) Use the dropproof plug assembly (AXT100-B04A) for the unused signal and power supply outlet port (G1/2).

L Dimension

n : Stations

n	2	3	4	5	6	7	8	9	10	11	12	13	14	15	16
L1	210.5	223	248	260.5	273	285.5	310.5	323	335.5	348	373	385.5	398	423	435.5
L2	200	212.5	237.5	250	262.5	275	300	312.5	325	337.5	362.5	375	387.5	412.5	425
L3	180.8	196.8	212.8	228.8	244.8	260.8	276.8	292.8	308.8	324.8	340.8	356.8	372.8	388.8	404.8
L4	15	13	17.5	16	14	12.5	17	15	13.5	11.5	16	14.5	12.5	17	15.5
L5	80	96	112	128	144	160	176	192	208	224	240	256	272	288	304

SV
SVJ
SZ
VF
VP4
S0700
VQ
VQ4
VQ5
VQC
VQC4
VQZ
SQ
VFS
VFR
VQ7

Dimensions: Series SV3000 for EX126 Integrated-type (For Output) Serial Transmission System

● Tie-rod base manifold : SS5V3-W10S4 □ D- $\frac{U}{B}$ -(Stations) $\frac{C6, N7}{C8, N9}$ (S, R, RS)- $\frac{C10, N11}{C10, N11}$ (-D)

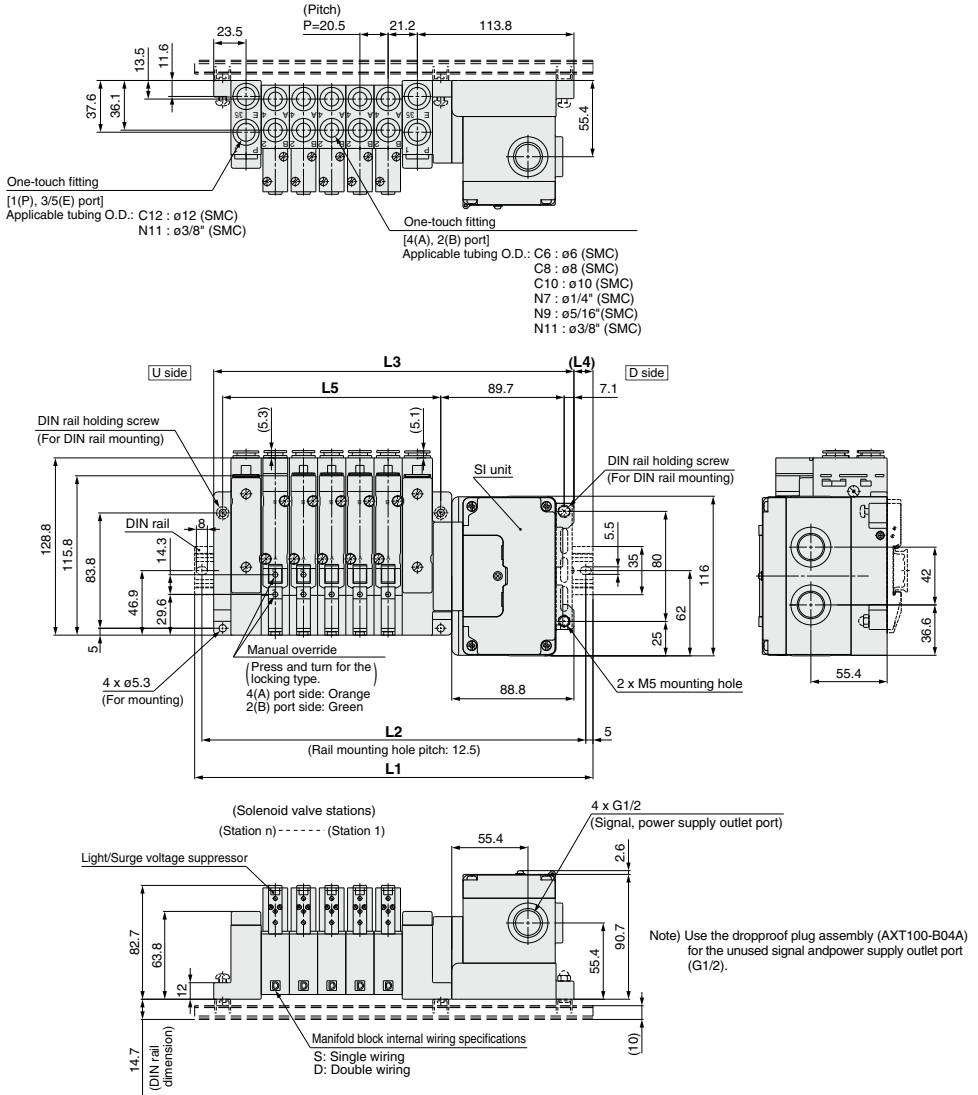

L Dimension

n	2	3	4	5	6	7	8	9	10	11	12	13	14	15	16
L1	235.5	248	273	285.5	310.5	335.5	348	373	398	410.5	435.5	460.5	473	498	510.5
L2	225	237.5	262.5	275	300	325	337.5	362.5	387.5	400	425	450	462.5	487.5	500
L3	200.3	220.8	241.3	261.8	282.3	302.8	323.3	343.8	364.3	384.8	405.3	425.8	446.3	466.8	487.3
L4	17.5	13.5	16	12	14	16.5	12.5	14.5	17	13	15	17.5	13.5	15.5	11.5
L5	97	117.5	138	158.5	179	199.5	220	240.5	261	281.5	302	322.5	343	363.5	384

Integrated-type (For Output) Serial Transmission System

Series EX120

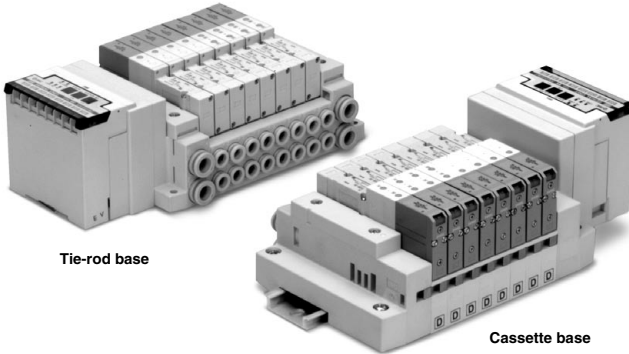

Tie-rod base

Cassette base

Applicable series

Cassette base manifold
SV1000/SV2000

Tie-rod base manifold
SV1000/SV2000/SV3000/SV4000

• Number of outputs points: 16 points

SJ
SY
SY
SV
SYJ
SZ
VF
VP4
S0700
VQ
VQ4
VQ5
VQC
VQC4
VQZ
SQ
VFS
VFR
VQ7

EX120 Integrated-type (For Output) Serial Transmission System Series SV



Note) Refer to "SI Unit Part No." when ordering the CE-compliant SI unit.

How to Order Manifold

Series

1	SV1000
2	SV2000
3	SV3000
4	SV4000

Series

1	SV1000
2	SV2000

SI Unit

Symbol	Specifications
0	Without SI unit
F1	NKE Corp.: Fieldbus System
H	NKE Corp.: Fieldbus H System
J1	Parasonic Industrial Devices SUNX Co., Ltd.: S-LINK (16 output points)
J2	Parasonic Industrial Devices SUNX Co., Ltd.: S-LINK (8 output points)
Q	DeviceNet
R1	OMRON Corp.: CompoBus/S (16 output points)
R2	OMRON Corp.: CompoBus/S (8 output points)
V	CC-LINK
ZB	CompoNet™ (Positive common)
ZBN	CompoNet™ (Negative common)

Valve stations

Symbol	Stations	Note
02	2 stations	Double wiring specifications (1)
∴	∴	
08	8 stations	
02	2 stations	Specified layout (2)
∴	∴	
16	16 stations	

Note 1) Double wiring specifications: Single, double, 3 position and 4 position solenoid valves can be used on all manifold stations. Use of a single solenoid will result in an unused control signal. If this is not desired, order with a specified layout.
Note 2) Specified layout: Indicate wiring specifications on a manifold specificationsheet. (Note that double, 3 and 4 position valves cannot be used where single solenoid wiring has been specified.)

Mounting

Nil	Direct mounting
D	DIN rail mounting (With DIN rail)
D0	DIN rail mounting (Without DIN rail)
D3	For 3 stations (When a longer DIN rail is desired than the specified stations. (Specify a longer rail than the standard length.)
∴	∴
D16	For 16 stations (Specify a longer rail than the standard length.)

* In the case of D0, only DIN rail fittings are attached.

DIN rail length specified

Nil	Standard length
3	For 3 stations (Specify a longer rail length.)
∴	∴
16	For 16 stations (Specify a longer rail length.)

SUP/EXH block assembly specifications

Nil	Internal pilot
S	Internal pilot/Built-in silencer
R	External pilot
RS	External pilot/Built-in silencer

P, E port location

U	U side (2 to 10 stations)
D	D side (2 to 10 stations)
B	Both sides (2 to 16 stations)

Tie-rod base

Cassette base

SI Unit Part No.				A, B port size (Metric)				A, B port size (Inch)			
Symbol	Protocol type	SI unit part no.	∴compt	Symbol	A, B port	P, E port	Applicable series	Symbol	A, B port	P, E port	Applicable series
F1	NKE Corp.: Fieldbus System	EX120-SUW1	—	C3	One-touch fitting for ø3.2	One-touch fitting for ø8	SV1000	N1	One-touch fitting for ø1/8"	One-touch fitting for ø5/16"	SV1000
H	NKE Corp.: Fieldbus H System	EX120-SUH1	—	C4	One-touch fitting for ø4	One-touch fitting for ø8	SV1000	N3	One-touch fitting for ø5/32"	One-touch fitting for ø5/16"	SV1000
J1	Parasonic Industrial Devices SUNX Co., Ltd.: S-LINK (16 output points)	EX120-SSL1	—	C6	One-touch fitting for ø6	One-touch fitting for ø10	SV2000	N7	One-touch fitting for ø1/4"	One-touch fitting for ø3/8"	SV2000
J2	Parasonic Industrial Devices SUNX Co., Ltd.: S-LINK (8 output points)	EX120-SSL2	—	C4	One-touch fitting for ø4	One-touch fitting for ø10	SV2000	N3	One-touch fitting for ø5/32"	One-touch fitting for ø3/8"	SV2000
Q	DeviceNet	EX120-SDN1	●	C6	One-touch fitting for ø6	One-touch fitting for ø12	SV3000	N7	One-touch fitting for ø1/4"	One-touch fitting for ø3/8"	SV3000
R1	OMRON Corp.: CompoBus/S (16 output points)	EX120-SCS1	●	C8	One-touch fitting for ø8	One-touch fitting for ø12	SV3000	N9	One-touch fitting for ø5/16"	One-touch fitting for ø3/8"	SV3000
R2	OMRON Corp.: CompoBus/S (8 output points)	EX120-SCS2	●	C6	One-touch fitting for ø6	One-touch fitting for ø12	SV3000	N7	One-touch fitting for ø1/4"	One-touch fitting for ø3/8"	SV3000
V	CC-LINK	EX120-SMJ1	●	C8	One-touch fitting for ø8	One-touch fitting for ø12	SV3000	N9	One-touch fitting for ø5/16"	One-touch fitting for ø3/8"	SV3000
ZB	CompoNet™ (Positive common)	EX120-SCM1	●	C10	One-touch fitting for ø10	One-touch fitting for ø12	SV4000	N11	One-touch fitting for ø3/8"	One-touch fitting for ø3/8"	SV4000
ZBN	CompoNet™ (Negative common)	EX120-SCM3	●	C12	One-touch fitting for ø12	One-touch fitting for ø12	SV4000	N11	One-touch fitting for ø3/8"	One-touch fitting for ø3/8"	SV4000
Refer to page 2051 and the Operation Manual for the details of EX120 Integrated-type (For Output) Serial Transmission System. Please download the Operation Manual via our website, http://www.smcworld.com.				02	Rc 1/4	Rc 3/8	SV4000	02N	NPT 1/4	NPT 3/8	SV4000
				03	Rc 3/8	Rc 3/8	SV4000	03N	NPT 3/8	NPT 3/8	SV4000
				02F	G 1/4	G 3/8	SV4000	02T	NPTF 1/4	NPTF 3/8	SV4000
				03F	G 3/8	G 3/8	SV4000	03T	NPTF 3/8	NPTF 3/8	SV4000
				M	A, B ports mixed			M	A, B ports mixed		

In the case of mixed specifications (M), indicate separately on the manifold specification sheet.
* Port sizes of X, P, E port for external pilot specification (R, RS) are ø4 (metric), ø5/32" (inch) for SV1000/2000 and ø6 (metric) and ø1/4" (inch) for SV3000/4000.



How to Order Manifold Assembly

Ordering example (SV1000)

Manifold

SS5V1-16S3AD-06B-C6 (1 set)

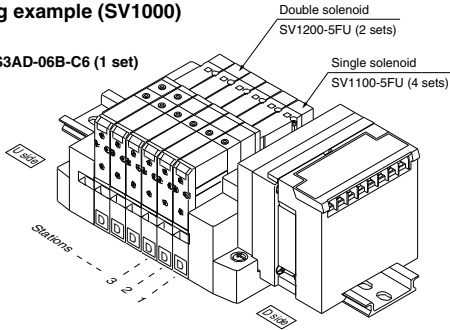

SS5V1-16S3CD-06B-C6 1 set (manifold part no.)
 * SV1100-5FU 4 sets (Single solenoid part no.)
 * SV1200-5FU 2 sets (Double solenoid part no.)

How to Order Solenoid Valves

SV 1 1 0 0 - 5 F - [] [] [] [] [] [] [] [] [] []

Series

1	SV1000
2	SV2000
3	SV3000
4	SV4000

Type of actuation

1	2 position single
2	2 position double
3	3 position closed center
4	3 position exhaust center
5	3 position pressure center
A	4 position dual 3 port valve: N.C./N.C.
B	4 position dual 3 port valve: N.O./N.O.
C	4 position dual 3 port valve: N.C./N.O.

* 4 position dual 3 port valves are applicable to Series SV1000 and SV2000 only.

Pilot type

Nil	Internal pilot
R	External pilot

* External pilot specifications is not available for 4 position dual 3 port valves.

Rated voltage

5	24 VDC
---	--------

Back pressure check valve

Nil	None
K	Built-in

* Built-in back pressure check valve type is applicable to Series SV1000 only.
 * Back pressure check valve is not available for 3 position Valve.

Note) Available with manifold block for station additions. Refer to pages 625 and 631.

Made to Order

Nil	—
X90	Main valve fluoro rubber (Refer to page 646.)

Manual override

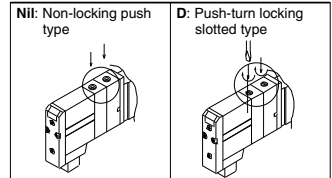

Light/Surge voltage suppressor

U	With light/surge voltage suppressor
R	With surge voltage suppressor

Note) Refer to Specific Product Precautions 2 on page 648.

SJ
SY
SY
SV
SYJ
SZ
VF
VP4
S0700
VQ
VQ4
VQ5
VQC
VQC4
VQZ
SQ
VFS
VFR
VQ7

Series SV

Dimensions: Series SV1000 for EX120 Integrated-type (For Output) Serial Transmission System

● Cassette base manifold : SS5V1-16S3 □ D- Stations $\frac{U}{D}$ (S, R, RS) C3, N1
C4, N3
C6, N7

- When P, E port outlets are indicated on the U side or D side, the P, E ports on the opposite side are plugged.
- External pilot port positions and silencer discharge port positions are the same as P, E port outlet positions.

With External Pilot Specifications

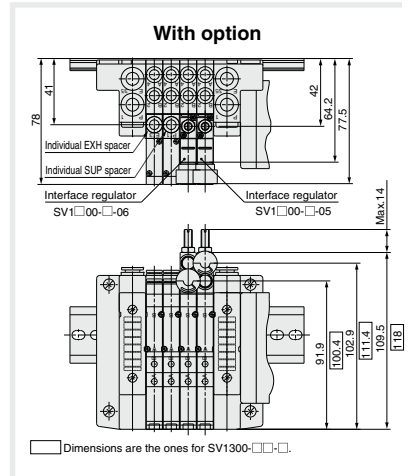
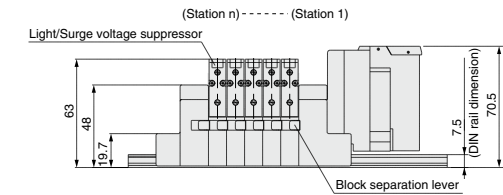
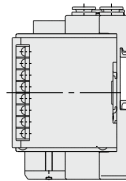
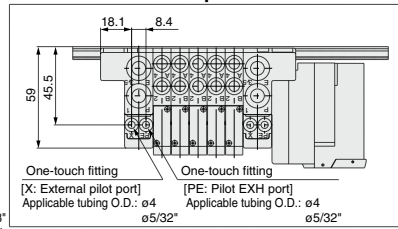
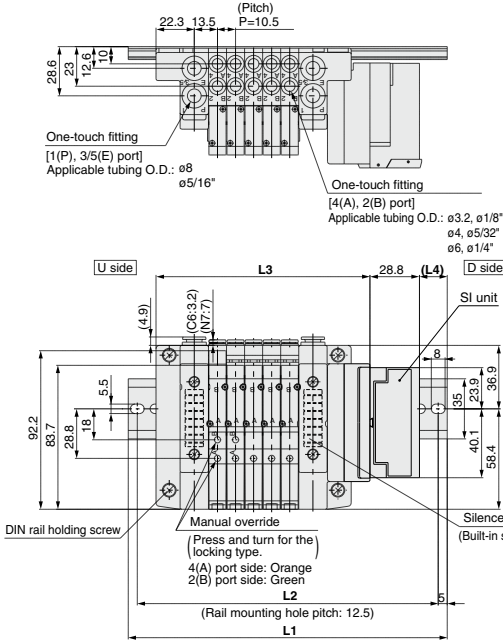

L Dimension

$\frac{L}{n}$	2	3	4	5	6	7	8	9	10	11	12	13	14	15	16
L1	148	160.5	173	185.5	198	198	210.5	223	235.5	248	260.5	260.5	273	285.5	298
L2	137.5	150	162.5	175	187.5	187.5	200	212.5	225	237.5	250	250	262.5	275	287.5
L3	92.9	103.4	113.9	124.4	134.9	145.4	155.9	166.4	176.9	187.4	197.9	208.4	218.9	229.4	239.9
L4	13	14	15	16	17	12	13	14	15	16	17	11.5	12.5	13.5	14.5

n : Stations

Dimensions: Series SV2000 for EX120 Integrated-type (For Output) Serial Transmission System

● Cassette base manifold : SS5V2-16S3 □ D- Stations $\frac{U}{D}$ (S, R, RS) $\frac{C4, N3}{C6, N7}$ $\frac{C8, N9}{C8, N9}$

- When P, E port outlets are indicated on the U side or D side, the P, E ports on the opposite side are plugged.
- External pilot port positions and silencer discharge port positions are the same as P, E port outlet positions.

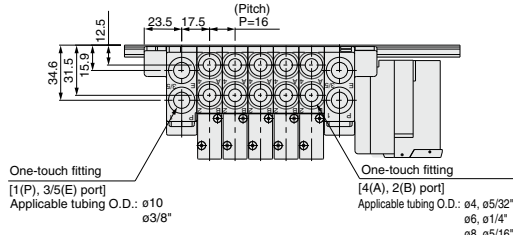

With External Pilot Specifications

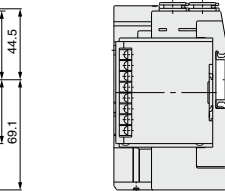
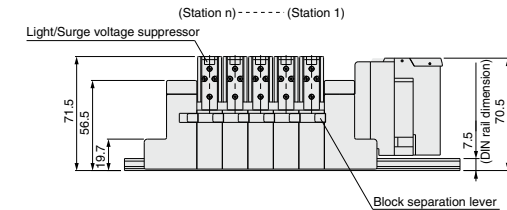
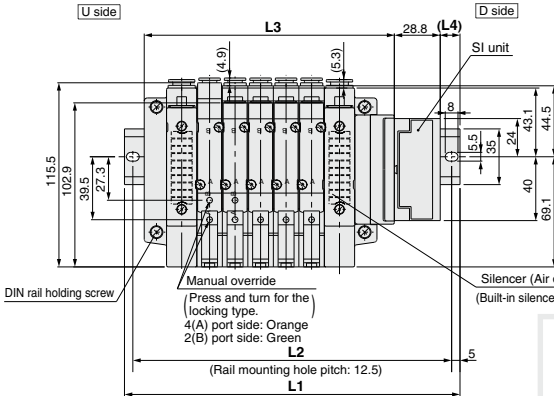
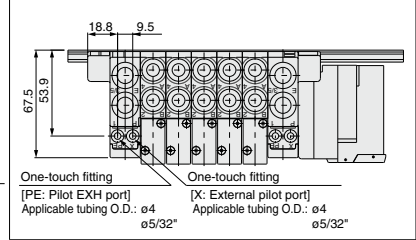

With option

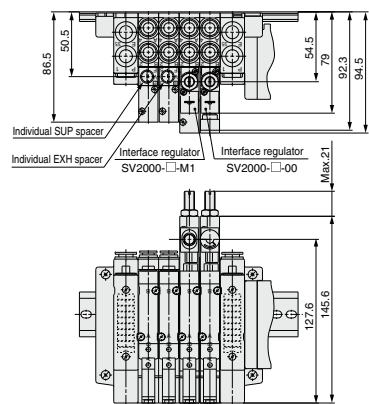

L Dimension

n : Stations

n	2	3	4	5	6	7	8	9	10	11	12	13	14	15	16
L1	173	185.5	198	210.5	235.5	248	260.5	273	298	310.5	323	348	360.5	373	385.5
L2	162.5	175	187.5	200	225	237.5	250	262.5	287.5	300	312.5	337.5	350	362.5	375
L3	108.9	124.9	140.9	156.9	172.9	188.9	204.9	220.9	236.9	252.9	268.9	284.9	300.9	316.9	332.9
L4	17.5	16	14	12.5	17	15	13.5	11.5	16	14.5	12.5	17	15.5	13.5	12

SJ
SY
SY
SV
SYJ
SZ
VF
VP4
S0700
VQ
VQ4
VQ5
VQC
VQC4
VQZ
SQ
VFS
VFR
VQ7

Dimensions: Series SV1000 for EX120 Integrated-type (For Output) Serial Transmission System

● Tie-rod base manifold : SS5V1-10S3 □ D- Stations $\frac{U}{D}$ (S, R, RS) $\frac{C3, N1}{C6, N7}$ (D)

- When P, E port outlets are indicated on the U side or D side, the P, E ports on the opposite side are plugged.
- External pilot port positions and silencer discharge port positions are the same as P, E port outlet positions.

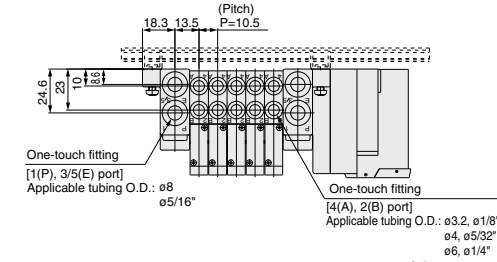

With External Pilot Specifications

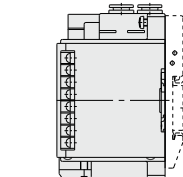
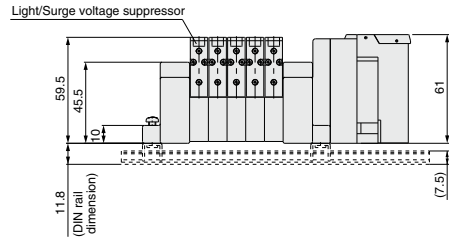
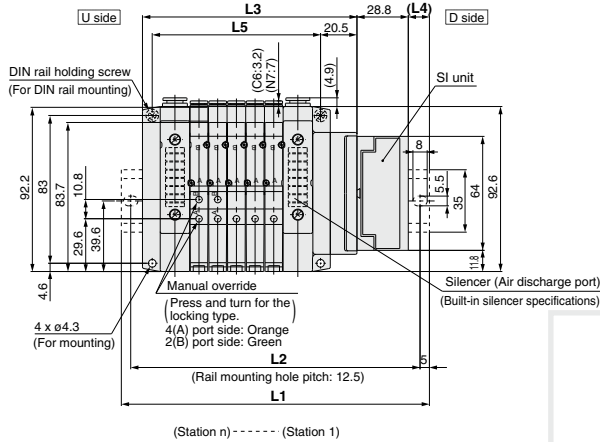
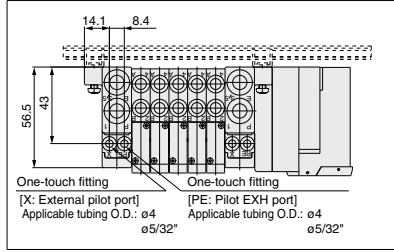

With option

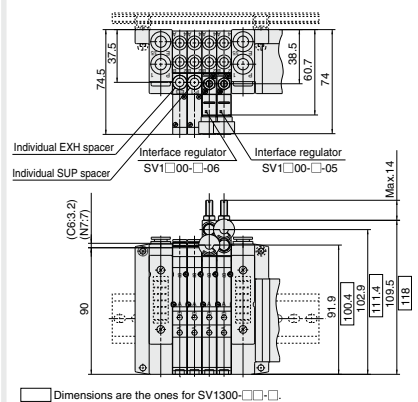

L Dimension

n : Stations

L \ n	2	3	4	5	6	7	8	9	10	11	12	13	14	15	16
L1	148	160.5	173	173	185.5	198	210.5	223	235.5	235.5	248	260.5	273	285.5	298
L2	137.5	150	162.5	162.5	175	187.5	200	212.5	225	225	237.5	250	262.5	275	287.5
L3	89	99.5	110	120.5	131	141.5	152	162.5	173	183.5	194	204.5	215	225.5	236
L4	15	16	17	12	13	14	15	16	17	11.5	12.5	13.5	14.5	15.5	16.5
L5	63	73.5	84	94.5	105	115.5	126	136.5	147	157.5	168	178.5	189	199.5	210

Dimensions: Series SV2000 for EX120 Integrated-type (For Output) Serial Transmission System

● Tie-rod base manifold : SS5V2-10S3 □ D- $\left[\begin{matrix} \text{Stations} \\ \text{U} \\ \text{S, R, RS} \end{matrix} \right]_{\text{B}} \begin{matrix} \text{C4, N3} \\ \text{C6, N7} \\ \text{C8, N9} \end{matrix} \text{(-D)}$

- When P, E port outlets are indicated on the U side or D side, the P, E ports on the opposite side are plugged.
- External pilot port positions and silencer discharge port positions are the same as P, E port outlet positions.

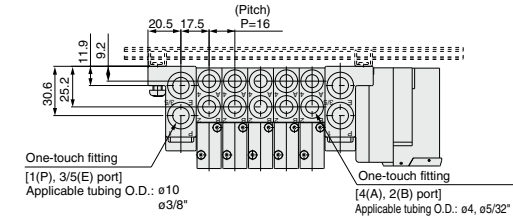

With External Pilot Specifications

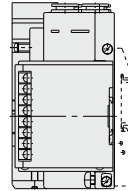
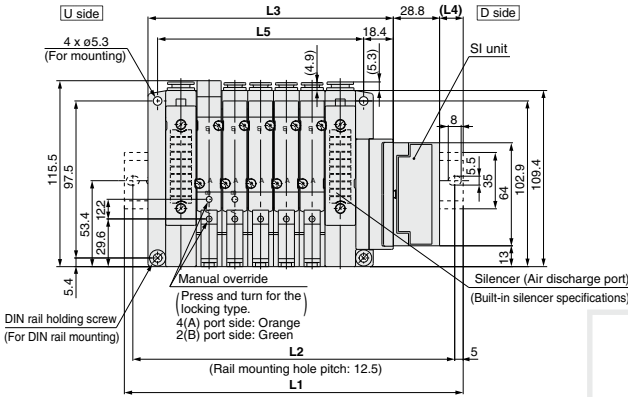
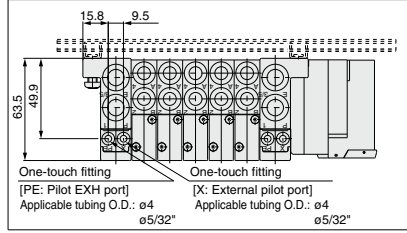

With option

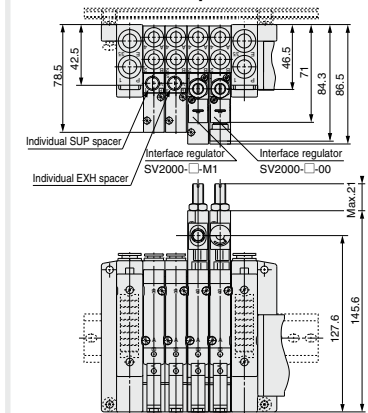

L Dimension

$\frac{L}{n}$	2	3	4	5	6	7	8	9	10	11	12	13	14	15	16
L1	160.5	173	198	210.5	223	248	260.5	273	285.5	310.5	323	335.5	360.5	373	385.5
L2	150	162.5	187.5	200	212.5	237.5	250	262.5	275	300	312.5	325	350	362.5	375
L3	104.4	120.4	136.4	152.4	168.4	184.4	200.4	216.4	232.4	248.4	264.4	280.4	296.4	312.4	328.4
L4	13.5	12	16.5	14.5	13	17.5	15.5	14	12	16.5	15	13	17.5	16	14
L5	80	96	112	128	144	160	176	192	208	224	240	256	272	288	304

n : Stations

SJ
SY
SY
SV
SYJ
SZ
VF
VP4
S0700
VQ
VQ4
VQ5
VQC
VQC4
VQZ
SQ
VFS
VFR
VQ7

Series SV

Dimensions: Series SV3000 for EX120 Integrated-type (For Output) Serial Transmission System

● Tie-rod base manifold : SS5V3-10S3 □ D- Stations $\frac{U}{D}$ (S, R, RS) $\frac{C6, N7}{C10, N11}$ (-D)

- When P, E port outlets are indicated on the U side or D side, the P, E ports on the opposite side are plugged.
- External pilot port positions and silencer discharge port positions are the same as P, E port outlet positions.

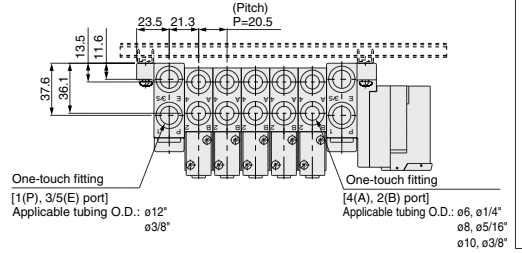

With External Pilot Specifications

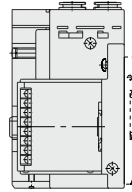
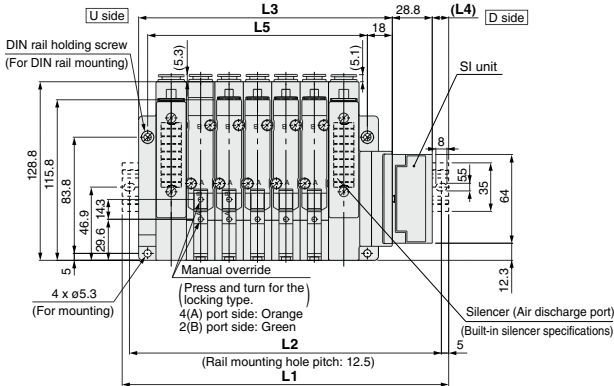
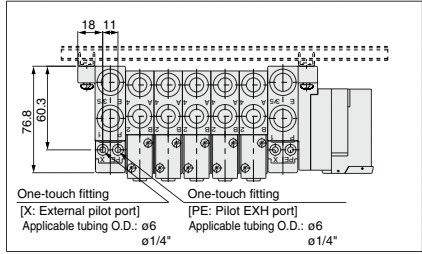

With option

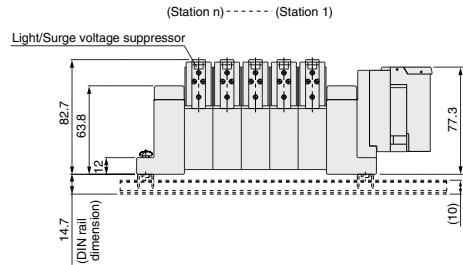
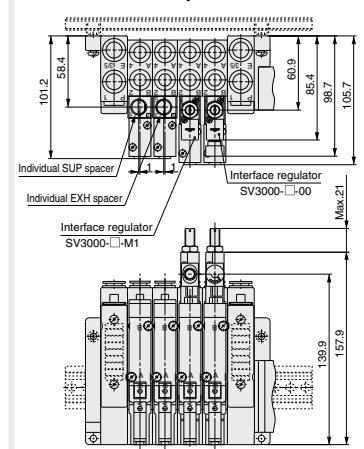

L Dimension

L	2	3	4	5	6	7	8	9	10	11	12	13	14	15	16
L1	185.5	198	223	235.5	260.5	285.5	298	323	348	360.5	385.5	410.5	423	448	460.5
L2	175	187.5	212.5	225	250	275	287.5	312.5	337.5	350	375	400	412.5	437.5	450
L3	121.5	142	162.5	183	203.5	224	244.5	265	285.5	306	326.5	347	367.5	388	408.5
L4	17.5	13.5	16	12	14	16.5	12.5	14.5	17	13	15	17.5	13.5	15.5	11.5
L5	97	117.5	138	158.5	179	199.5	220	240.5	261	281.5	302	322.5	343	363.5	384

n : Stations

Dimensions: Series SV4000 for EX120 Integrated-type (For Output) Serial Transmission System

● Tie-rod base manifold : SS5V4-10S3 □ D- $\left[\begin{matrix} \text{Stations} \\ \text{S, R, RS} \end{matrix} \right]_{\text{S}}^{\text{U}}$ (S, R, RS) $\left[\begin{matrix} \text{C8, N9, C10, N11} \\ \text{C12} \end{matrix} \right]_{\text{S}}^{\text{U}}$ (-D)

- When P, E port outlets are indicated on the U side or D side, the P, E ports on the opposite side are plugged.
- External pilot port positions and silencer discharge port positions are the same as P, E port outlet positions.

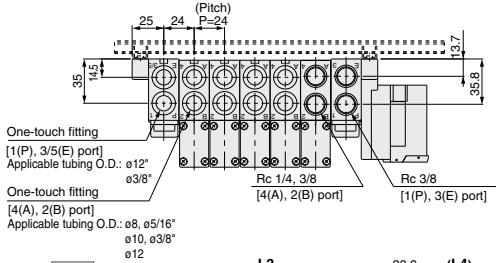

With External Pilot Specifications

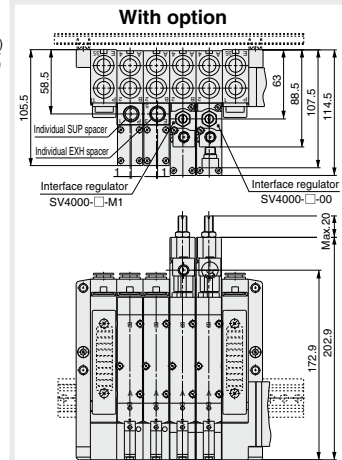
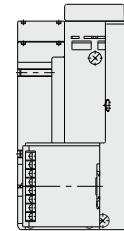
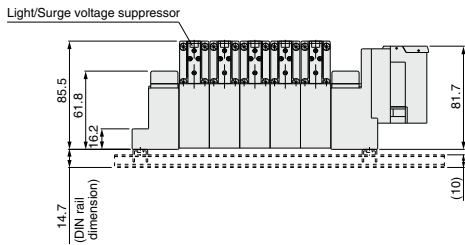
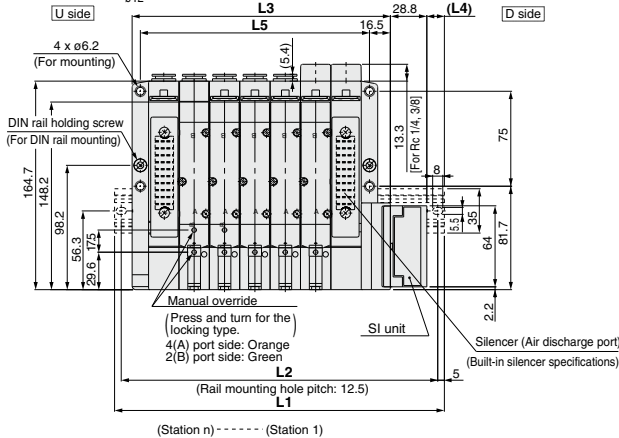
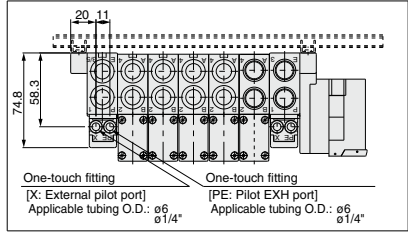

L Dimension

L/n	2	3	4	5	6	7	8	9	10	11	12	13	14	15	16
L1	185.5	210.5	235.5	260.5	285.5	310.5	335.5	360.5	385.5	410.5	435.5	448	473	498	523
L2	175	200	225	250	275	300	325	350	375	400	425	437.5	462.5	487.5	512.5
L3	132	156	180	204	228	252	276	300	324	348	372	396	420	444	468
L4	12.5	13	13.5	14	14.5	15	15.5	16	16.5	17	17.5	17.5	18	12.5	13
L5	109	133	157	181	205	229	253	277	301	325	349	373	397	421	445

n : Stations

Circular Connector

IP67 compliant

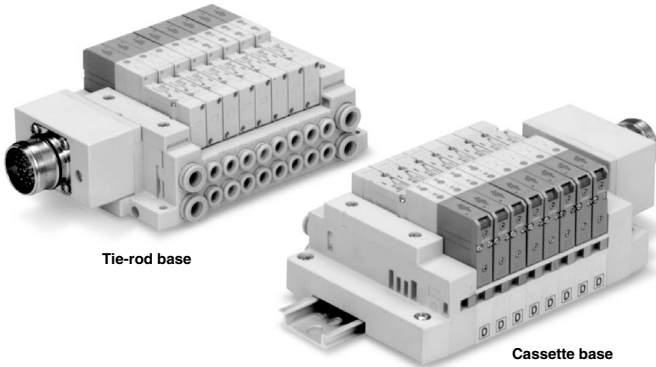

Applicable series	Cassette base manifold SV1000/SV2000
	Tie-rod base manifold SV1000/SV2000/SV3000/SV4000
• Number of connectors: 26 pins	

SJ
SY
SY
SV
SYJ
SZ
VF
VP4
S0700
VQ
VQ4
VQ5
VQC
VQC4
VQZ
SQ
VFS
VFR
VQ7

Circular Connector Series SV



How to Order Manifold

Series

1	SV1000
2	SV2000
3	SV3000
4	SV4000

Valve stations

Symbol	Stations	Note
02	2 stations	Double wiring specifications (1)
:	:	
:	:	
12	12 stations	Specified layout (2) (Up to 24 solenoids possible.)
02	2 stations	
:	:	
20	20 stations	

Mounting

Nil	Direct mounting
D	DIN rail mounting (With DIN rail)
D0	DIN rail mounting (Without DIN rail)
D3	For 3 stations
:	:
:	:
D20	For 20 stations

DIN rail length specified

Nil	Standard length
3	For 3 stations
:	:
:	:
20 ^{Note1}	For 20 stations

Valve stations

Symbol	Stations	Note
02	2 stations	Double wiring specifications (1)
:	:	
:	:	
09	9 stations	Specified layout (2) (up to 18 solenoids possible.)
02	2 stations	
:	:	
18	18 stations	

Type 16: Series SV1000

Symbol	Stations	Note
02	2 stations	Double wiring specifications (1)
:	:	
:	:	
12	12 stations	Specified layout (2) (up to 24 solenoids possible.)
02	2 stations	
:	:	
20	20 stations	

Type 16: Series SV2000

Symbol	Stations	Note
02	2 stations	Double wiring specifications (1)
:	:	
:	:	
12	12 stations	Specified layout (2) (up to 24 solenoids possible.)
02	2 stations	
:	:	
20	20 stations	

P, E port location

U	U side (2 to 10 stations)
D	D side (2 to 10 stations)
B	Both sides (2 to 20 stations)

SUP/EXH block assembly specifications

Nil	Internal pilot
S*	Internal pilot/Built-in silencer
R	External pilot
RS*	External pilot/Built-in silencer

Enclosure IP67 specifications

Series

1	SV1000
2	SV2000

Valve stations

Symbol	Stations	Note
02	2 stations	Double wiring specifications (1)
:	:	
:	:	
12	12 stations	Specified layout (2) (up to 24 solenoids possible.)
02	2 stations	
:	:	
20	20 stations	

Mounting

Nil	Direct mounting
D	DIN rail mounting (With DIN rail)
D0	DIN rail mounting (Without DIN rail)
D3	For 3 stations
:	:
:	:
D20	For 20 stations

DIN rail length specified

Nil	Standard length
3	For 3 stations
:	:
:	:
20 ^{Note1}	For 20 stations

A, B port size (Metric)

Symbol	Specifications	P, E port	Applicable series
C3	One-touch fitting for ø3.2	One-touch fitting for ø8	SV1000
C4	One-touch fitting for ø4		
C6	One-touch fitting for ø6		
C4	One-touch fitting for ø4	One-touch fitting for ø10	SV2000
C6	One-touch fitting for ø6		
C8	One-touch fitting for ø8		
C6	One-touch fitting for ø6	One-touch fitting for ø12	SV3000
C8	One-touch fitting for ø8		
C10	One-touch fitting for ø10		
C8	One-touch fitting for ø8	One-touch fitting for ø12	SV4000
C10	One-touch fitting for ø10		
C12	One-touch fitting for ø12		
02	Rc 1/4	Rc 3/8	SV4000
03	Rc 3/8		
02F	G 1/4		
03F	G 3/8	G 3/8	
M	A, B ports mixed		

A, B port size (Inch)

Symbol	Specifications	P, E port	Applicable series
N1	One-touch fitting for ø1/8"	One-touch fitting for ø5/16"	SV1000
N3	One-touch fitting for ø5/32"		
N7	One-touch fitting for ø1/4"		
N3	One-touch fitting for ø5/32"	One-touch fitting for ø3/8"	SV2000
N7	One-touch fitting for ø1/4"		
N9	One-touch fitting for ø5/16"		
N7	One-touch fitting for ø1/4"	One-touch fitting for ø3/8"	SV3000
N9	One-touch fitting for ø5/16"		
N11	One-touch fitting for ø3/8"		
N9	One-touch fitting for ø5/16"	One-touch fitting for ø3/8"	SV4000
N11	One-touch fitting for ø3/8"		
02N	NPT 1/4		
03N	NPT 3/8	NPTF 3/8	SV4000
02T	NPTF 1/4		
03T	NPTF 3/8		
M	A, B ports mixed		



*In the case of mixed specifications (M), indicate separately on the manifold specification sheet.
*Port sizes of X, PE port for external pilot specification (R, RS) are ø4(metric), ø5/32"(inch) for SV1000/2000 and ø6 (metric) and ø1/4"(inch) for SV3000/4000.

How to Order Manifold Assembly

Ordering example (SV1000)

Manifold
SS5V1-W16CD-06B-C6 (1 set)

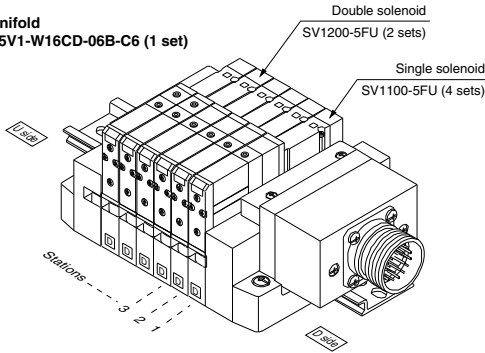

SS5V1-W16CD-06B-C6.....1 set (Manifold part no.)
* SV1100-5FU.....4 sets (Single solenoid part no.)
* SV1200-5FU.....2 sets (Double solenoid part no.)

How to Order Solenoid Valves

SV 1 1 0 0 - 5 F - - -

Series

1	SV1000
2	SV2000
3	SV3000
4	SV4000

Type of actuation

1	2 position single
2	2 position double
3	3 position closed center
4	3 position exhaust center
5	3 position pressure center
A	4 position dual 3 port valve: N.C./N.C.
B	4 position dual 3 port valve: N.O./N.O.
C	4 position dual 3 port valve: N.C./N.O.

* 4 position dual 3 port valves are applicable to Series SV1000 and SV2000 only.

Pilot type

Nil	Internal pilot
R	External pilot

* External pilot specifications is not available for 4 position dual 3 port valves.

Back pressure check valve

Nil	None
K	Built-in

* Built-in back pressure check valve type is applicable to series SV1000 only.
* Back pressure check valve is not available for 3 position valve.

Rated voltage

5	24 VDC
6	12 VDC

Note)

Note) Available with manifold block for station additions. Refer to pages 625 and 631.

Made to Order

Nil	—
X90	Main valve fluororubber (Refer to page 646.)

Manual override

Nil: Non-locking push type

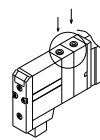

D: Push-turn locking slotted type

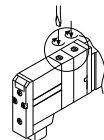

Light/Surge voltage suppressor

U	With light/surge voltage suppressor
R	With surge voltage suppressor

Note) Refer to Specific Product Precautions 2 on page 648.

- SV
- SVJ
- SZ
- VF
- VP4
- S0700
- VQ
- VQ4
- VQ5
- VQC
- VQC4
- VQZ
- SQ
- VFS
- VFR
- VQ7

Manifold Electrical Wiring

10C/16C Circular Connector Type (26 pins)		
	Terminal no.	Polarity
Station 1	SOL_01	(-) (+)
	SOL_02	(-) (+)
Station 2	SOL_03	(-) (+)
	SOL_04	(-) (+)
Station 3	SOL_05	(-) (+)
	SOL_06	(-) (+)
Station 4	SOL_07	(-) (+)
	SOL_08	(-) (+)
Station 5	SOL_09	(-) (+)
	SOL_10	(-) (+)
Station 6	SOL_11	(-) (+)
	SOL_12	(-) (+)
Station 7	SOL_13	(-) (+)
	SOL_14	(-) (+)
Station 8	SOL_15	(-) (+)
	SOL_16	(-) (+)
Station 9	SOL_17	(-) (+)
	SOL_18	(-) (+)
Station 10	SOL_19	(-) (+)
	SOL_20	(-) (+)
Station 11	SOL_21	(-) (+)
	SOL_22	(-) (+)
Station 12	SOL_23	(-) (+)
	SOL_24	(-) (+)
	COM_25	(+)
	COM_26	(+)

Positive common specification Negative common specification

- This circuit has double wiring specifications for up to 12 stations. Since the usable number of solenoids differs depending on the manifold type, refer to the table below. In the case of single solenoids, connect to SOL_ A. Furthermore, when wiring is specified on a manifold specification sheet, connections are made without skipping any connectors, and connections are made without skipping any connectors, and signals A for single and A, B for double are in order 1 → 2 → 3 → 4, etc.
- Stations are counted from D side (connector side) as the 1st.
- Since solenoid valves do not have polarity, either the +COM or -COM can be used.

Usable No. of Solenoids

Model		Max. no. of solenoids
Tie-rod base type 10	SV1000 to SV4000	24
	SV1000 SV2000	18
Cassette base type 16	SV2000	24

Dimensions: Series SV1000 for Circular Connector

● **Cassette base manifold: SS5V1-W16CD-^UStations_D (S, R, RS)-^{C3, N1}_{C4, N3}^{C5, N7}**

- When P, E port outlets are indicated on the U side or D side, the P, E ports on the opposite side are plugged.
- External pilot port positions and silencer discharge port positions are the same as P, E port outlet positions.

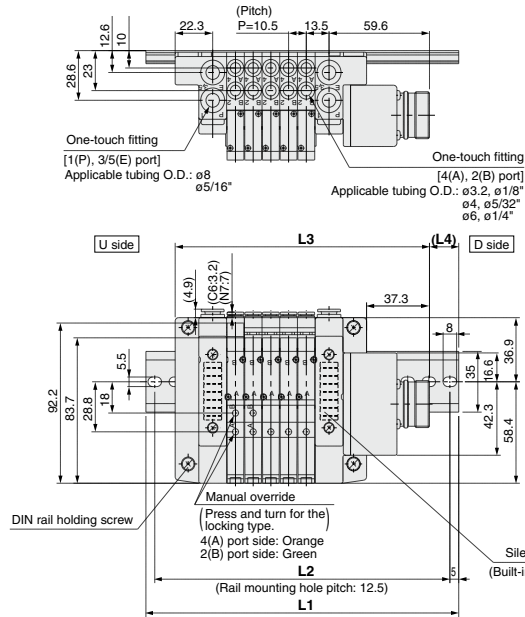

With External Pilot Specifications

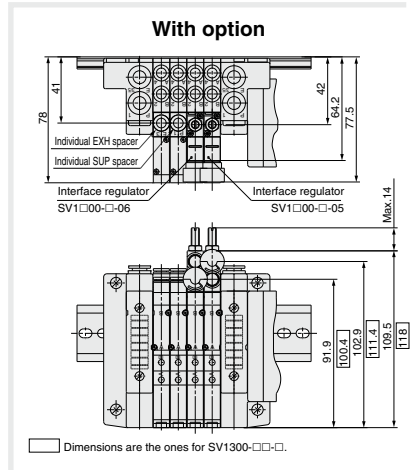
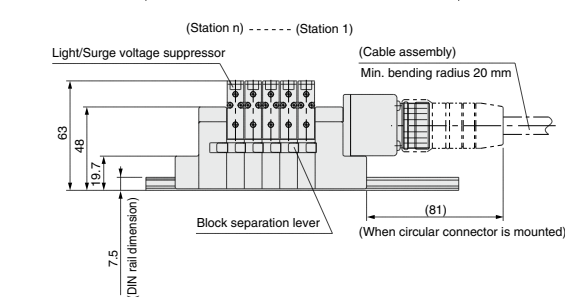
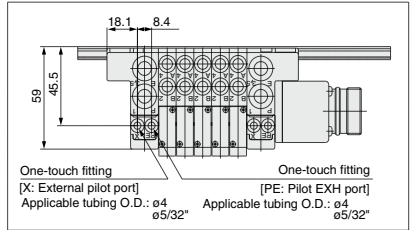

□ Dimensions are the ones for SV1300-□□□□.

L Dimension

n	2	3	4	5	6	7	8	9	10	11	12	13	14	15	16	17	18
L1	148	160.5	173	185.5	185.5	198	210.5	223	235.5	248	248	260.5	273	285.5	298	310.5	310.5
L2	137.5	150	162.5	175	175	187.5	200	212.5	225	237.5	237.5	250	262.5	275	287.5	300	300
L3	119.3	129.8	140.3	150.8	161.3	171.8	182.3	192.8	203.3	213.8	224.3	234.8	245.3	255.8	266.3	276.8	287.3
L4	14.5	15.5	16.5	17.5	12	13	14	15	16	17	12	13	14	15	16	17	11.5

n: Stations

- SJ
- SY
- SY
- SV
- SYJ
- SZ
- VF
- VP4
- S0700
- VQ
- VQ4
- VQ5
- VQC
- VQC4
- VQZ
- SQ
- VFS
- VFR
- VQ7

Dimensions: Series SV2000 for Circular Connector

● Cassette base manifold: SS5V2-W16CD-(Stations) $\frac{U}{D}$ (S, R, RS)- C4, N3 C6, N7 C8, N9

- When P, E port outlets are indicated on the U side or D side, the P, E ports on the opposite side are plugged.
- External pilot port positions and silencer discharge port positions are the same as P, E port outlet positions.

With External Pilot Specifications

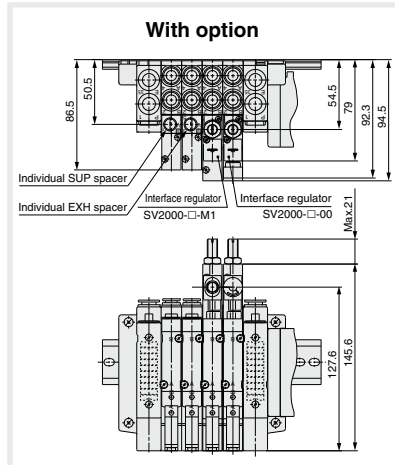
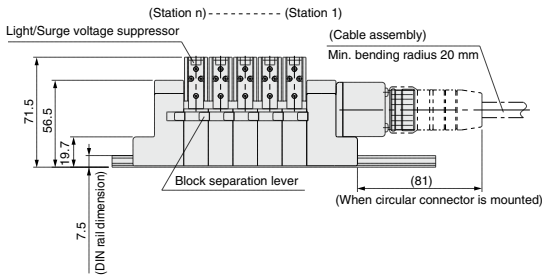
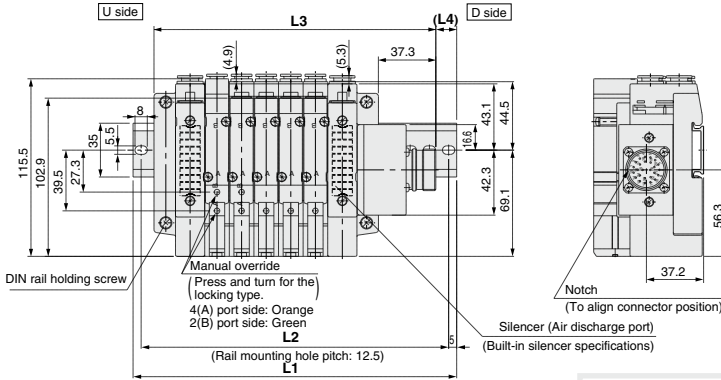
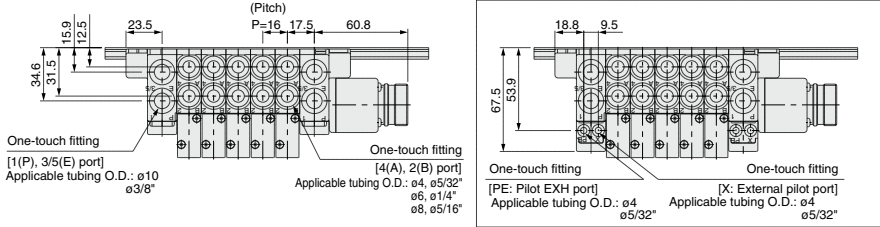

L Dimension

n	2	3	4	5	6	7	8	9	10	11	12	13	14	15	16	17	18	19	20
L1	160.5	185.5	198	210.5	223	248	260.5	273	298	310.5	323	335.5	360.5	373	385.5	410.5	423	435.5	448
L2	150	175	187.5	200	212.5	237.5	250	262.5	287.5	300	312.5	325	350	362.5	375	400	412.5	425	437.5
L3	135.3	151.3	167.3	183.3	199.3	215.3	231.3	247.3	263.3	279.3	295.3	311.3	327.3	343.3	359.3	375.3	391.3	407.3	423.3
L4	12.5	17	15.5	13.5	12	16.5	14.5	13	17.5	15.5	14	12	16.5	15	13	17.5	16	14	12.5

n: Stations

Dimensions: Series SV1000 for Circular Connector

● Tie-rod base manifold: SS5V1-W10CD-(Stations) $\frac{U}{D}$ (S, R, RS)-C3, N1
C4, N3 (-D)
C5, N7

- When P, E port outlets are indicated on the U side or D side, the P, E ports on the opposite side are plugged.
- External pilot port positions and silencer discharge port positions are the same as P, E port outlet positions.

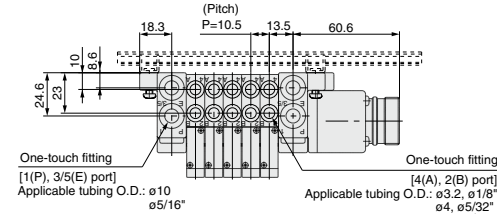

With External Pilot Specifications

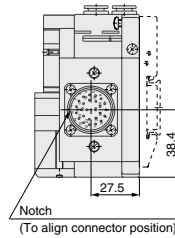
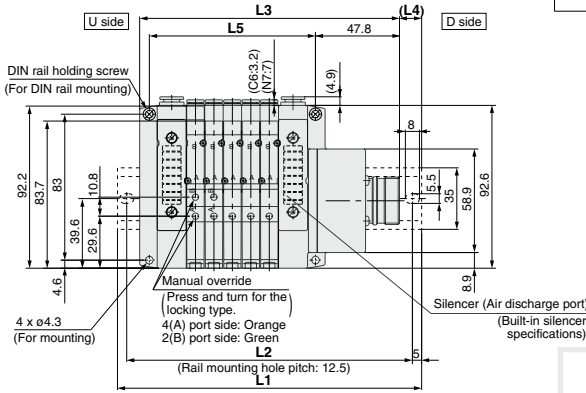
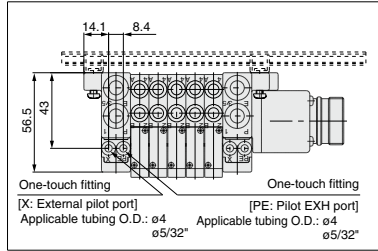

With option

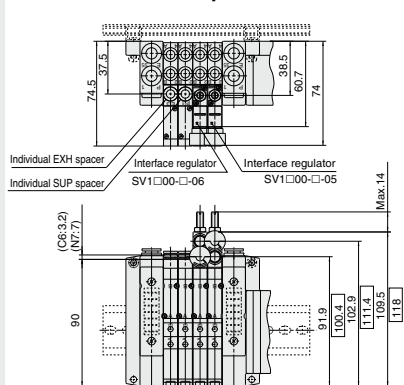

□ Dimensions are the ones for SV1300-□-□.

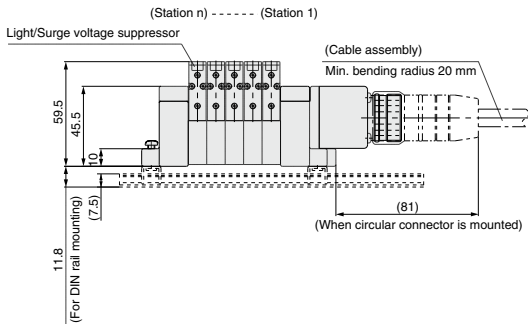

L Dimension

n	2	3	4	5	6	7	8	9	10	11	12	13	14	15	16	17	18	19	20
L1	148	160.5	160.5	173	185.5	198	210.5	223	235.5	235.5	248	260.5	273	285.5	298	298	310.5	323	335.5
L2	137.5	150	150	162.5	175	187.5	200	212.5	225	225	237.5	250	262.5	275	287.5	287.5	300	312.5	325
L3	116.3	128.8	137.3	147.8	158.3	168.8	179.3	189.8	200.3	210.8	221.3	231.8	242.3	252.8	263.3	273.8	284.3	294.8	305.3
L4	16	17	11.5	12.5	13.5	14.5	15.5	16.5	17.5	12.5	13.5	14.5	15.5	16.5	17.5	12	13	14	15
L5	63	73.5	84	94.5	105	115.5	126	136.5	147	157.5	168	178.5	189	199.5	210	220.5	231	241.5	252

n: Stations

- SJ
- SY
- SY
- SV**
- SYJ
- SZ
- VF
- VP4
- S0700
- VQ
- VQ4
- VQ5
- VQC
- VQC4
- VQZ
- SQ
- VFS
- VFR
- VQ7

Series SV

Dimensions: Series SV2000 for Circular Connector

● Tie-rod base manifold: SS5V2-W10CD- $\frac{U}{D}$ (S, R, RS)- $\frac{U}{D}$ C4, N3 C6, N7 (-D) C8, N8

- When P, E port outlets are indicated on the U side or D side, the P, E ports on the opposite side are plugged.
- External pilot port positions and silencer discharge port positions are the same as P, E port outlet positions.

With External Pilot Specifications

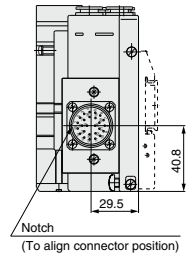
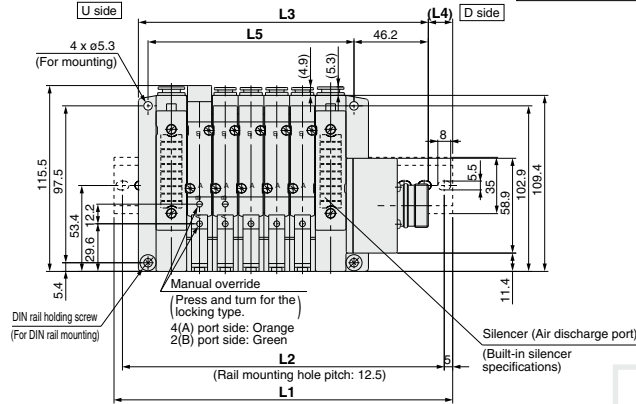
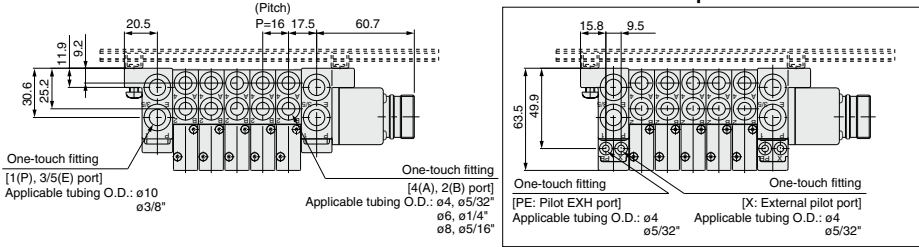

With option

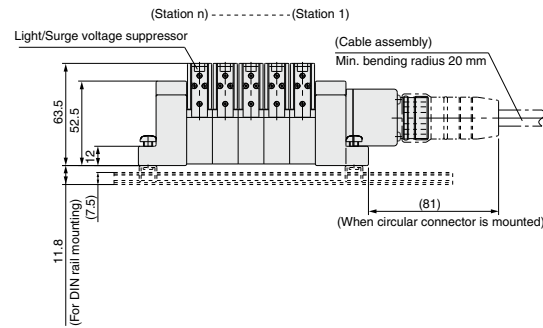
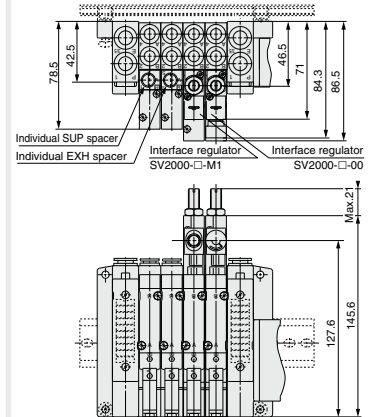

L Dimension

n	2	3	4	5	6	7	8	9	10	11	12	13	14	15	16	17	18	19	20
L1	160.5	173	198	210.5	223	235.5	260.5	273	285.5	310.5	323	335.5	348	373	385.5	398	423	435.5	448
L2	150	162.5	187.5	200	212.5	225	250	262.5	275	300	312.5	325	337.5	362.5	375	387.5	412.5	425	437.5
L3	132.2	148.2	164.2	180.2	196.2	212.2	228.2	244.2	260.2	276.2	292.2	308.2	324.2	340.2	356.2	372.2	388.2	404.2	420.2
L4	14	12.5	17	15	13.5	11.5	16	14.5	12.5	17	15.5	13.5	12	16.5	14.5	13	17.5	15.5	14
L5	80	96	112	128	144	160	176	192	208	224	240	256	272	288	304	320	336	352	368

Dimensions: Series SV3000 for Circular Connector

● Tie-rod base manifold: SS5V3-W10CD- $\frac{U}{D}$ (S, R, RS)- $\frac{C6, N7}{C8, N9}$ (-D)
C10, N11

- When P, E port outlets are indicated on the U side or D side, the P, E ports on the opposite side are plugged.
- External pilot port positions and silencer discharge port positions are the same as P, E port outlet positions.

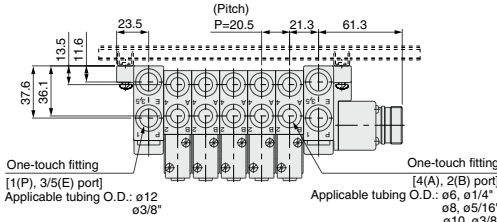

With External Pilot Specifications

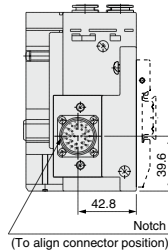
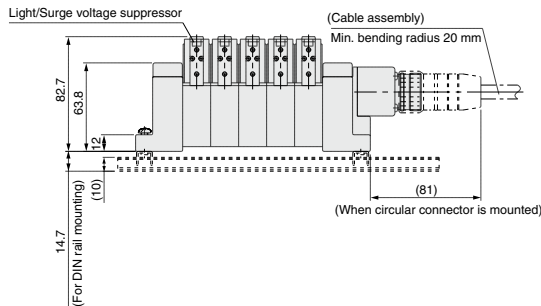
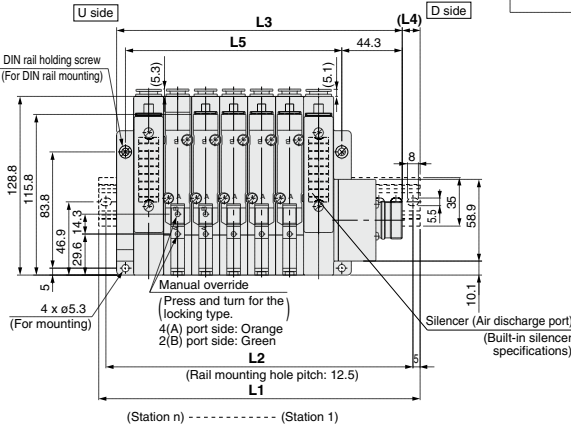
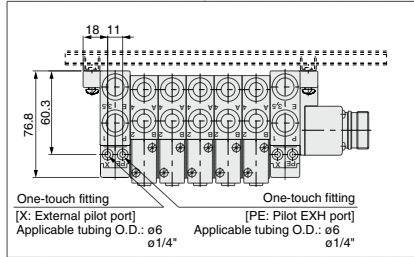

With option

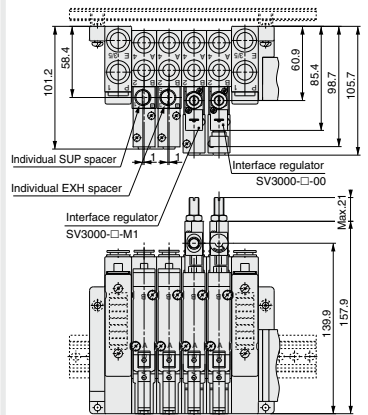

L Dimension

n	2	3	4	5	6	7	8	9	10	11	12	13	14	15	16	17	18	19	20
L1	173	198	223	235.5	260.5	285.5	298	323	335.5	360.5	385.5	398	423	448	460.5	485.5	510.5	523	548
L2	162.5	187.5	212.5	225	250	275	287.5	312.5	325	350	375	387.5	412.5	437.5	450	475	500	512.5	537.5
L3	147.8	168.3	188.8	209.3	229.8	250.3	270.8	291.3	311.8	332.3	352.8	373.3	393.8	414.3	434.8	455.3	475.8	496.3	516.8
L4	12.5	15	17	13	15.5	17.5	13.5	16	12	14	16.5	12.5	14.5	17	13	15	17.5	13.5	15.5
L5	97	117.5	138	158.5	179	199.5	220	240.5	261	281.5	302	322.5	343	363.5	384	404.5	425	445.5	466

n: Stations

- SV
- SVJ
- SZ
- VF
- VP4
- S0700
- VQ
- VQ4
- VQ5
- VQC
- VQC4
- VQZ
- SQ
- VFS
- VFR
- VQ7

Series SV

Dimensions: Series SV4000 for Circular Connector

● Tie-rod base manifold: SS5V4-W10CD- $\begin{matrix} \text{U} \\ \text{D} \end{matrix}$ (S, R, RS)- $\begin{matrix} \text{C8} \\ \text{C10, N9} \\ \text{C3, C2, N11} \end{matrix}$ (-D)

- When P, E port outlets are indicated on the U side or D side, the P, E ports on the opposite side are plugged.
- External pilot port positions and silencer discharge port positions are the same as P, E port outlet positions.

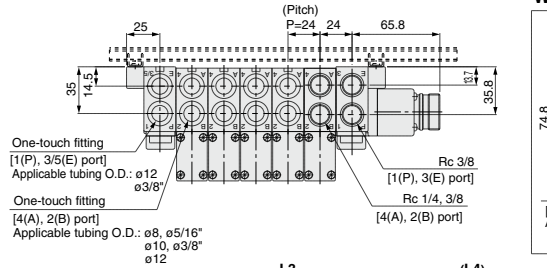

With External Pilot Specifications

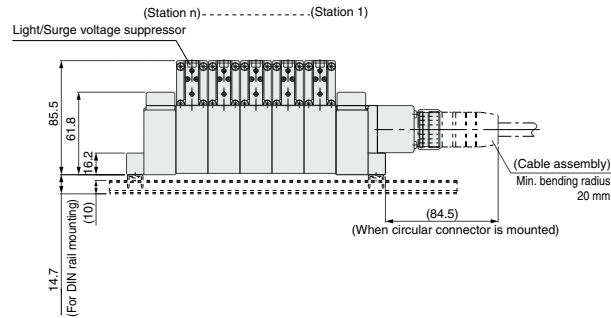
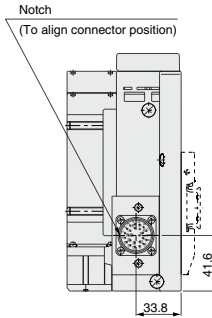
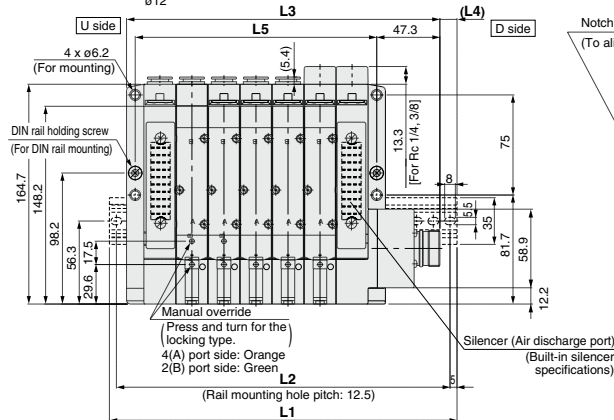
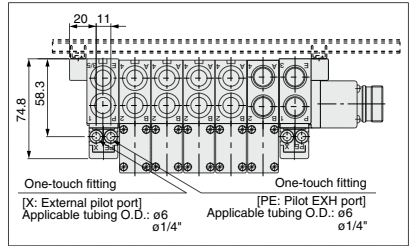

With option

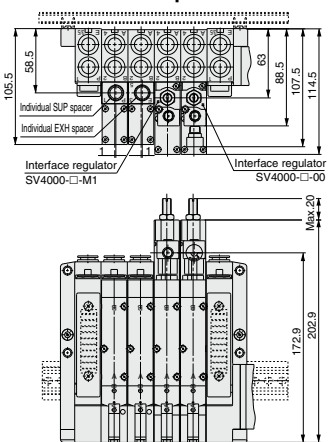

L Dimension

n	2	3	4	5	6	7	8	9	10	11	12	13	14	15	16	17	18	19	20
L1	198	210.5	235.5	260.5	285.5	310.5	335.5	360.5	385.5	410.5	435.5	460.5	485.5	498	523	548	573	598	623
L2	187.5	200	225	250	275	300	325	350	375	400	425	450	475	487.5	512.5	537.5	562.5	587.5	612.5
L3	162.8	186.8	210.8	234.8	258.8	282.8	306.8	330.8	354.8	378.8	402.8	426.8	450.8	474.8	498.8	522.8	546.8	570.8	594.8
L4	17.5	12	12.5	13	13.5	14	14.5	15	15.5	16	16.5	17	17.5	11.5	12	12.5	13	13.5	14
L5	109	133	157	181	205	229	253	277	301	325	349	373	397	421	445	469	493	517	541

D-sub Connector

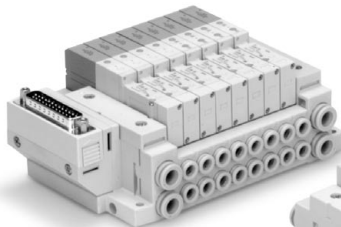

Tie-rod base

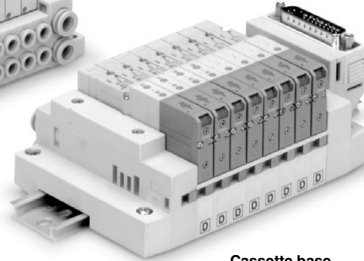

Cassette base

Applicable series

Cassette base manifold
SV1000/SV2000

Tie-rod base manifold
SV1000/SV2000/SV3000/SV4000

- Number of connectors: 25 pins
 - MIL-C-24308
- Conforming to JIS-X-5101

SJ
SY
SY
SV
SYJ
SZ
VF
VP4
S0700
VQ
VQ4
VQ5
VQC
VQC4
VQZ
SQ
VFS
VFR
VQ7

D-sub Connector Series SV



How to Order Manifold

Series

1	SV1000
2	SV2000
3	SV3000
4	SV4000

Series

1	SV1000
2	SV2000

Connector entry direction

1	Upward
2	Lateral

Valve stations

Symbol	Stations	Note
02	2 stations	Double wiring ⁽¹⁾ specifications
:	:	
11	11 stations	
02	2 stations	Specified layout ⁽²⁾ (Up to 23 solenoids possible.)
:	:	
20	20 stations	

Mounting

	Direct mounting
Nil	Direct mounting
D	DIN rail mounting (With DIN rail)
D0 ^{Note)}	DIN rail mounting (Without DIN rail)
D3	For 3 stations When a longer DIN rail is desired than the specified stations. (Specify a longer rail than the standard length.)
:	:
D20	For 20 stations (Specify a longer rail than the standard length.)

Valve stations

Series SV1000

Symbol	Stations	Note
02	2 stations	Double wiring ⁽¹⁾ specifications
:	:	
09	9 stations	
02	2 stations	Specified layout ⁽²⁾ (Up to 18 solenoids possible.)
:	:	
18	18 stations	

Series SV2000

Symbol	Stations	Note
02	2 stations	Double wiring ⁽¹⁾ specifications
:	:	
11	11 stations	
02	2 stations	Specified layout ⁽²⁾ (Up to 23 solenoids possible.)
:	:	
20	20 stations	

P, E port location

U	U side (2 to 10 stations)
D	D side (2 to 10 stations)
B	Both sides (2 to 20 stations)

Pilot type

Nil	Internal pilot
S	Internal pilot/Built-in silencer
R	External pilot
RS	External pilot/Built-in silencer

A, B port size (metric)

Symbol	A, B port	P, E port	Applicable series
C3	One-touch fitting for ø3,2	One-touch fitting for ø8	SV1000
C4	One-touch fitting for ø4		
C6	One-touch fitting for ø6		
C4	One-touch fitting for ø4	One-touch fitting for ø10	SV2000
C6	One-touch fitting for ø6		
C8	One-touch fitting for ø8		
C6	One-touch fitting for ø6	One-touch fitting for ø12	SV3000
C8	One-touch fitting for ø8		
C10	One-touch fitting for ø10		
C8	One-touch fitting for ø8	One-touch fitting for ø12	SV4000
C10	One-touch fitting for ø10		
C12	One-touch fitting for ø12		
02	Rc 1/4	Rc 3/8	SV4000
03	Rc 3/8		
02F	G 1/4		
03F	G 3/8	G 3/8	
M	A, B ports mixed		

A, B port size (inch)

Symbol	A, B port	P, E port	Applicable series
N1	One-touch fitting for ø1/8"	One-touch fitting for ø5/16"	SV1000
N3	One-touch fitting for ø5/32"		
N7	One-touch fitting for ø1/4"		
N3	One-touch fitting for ø5/32"	One-touch fitting for ø3/8"	SV2000
N7	One-touch fitting for ø1/4"		
N9	One-touch fitting for ø5/16"		
N7	One-touch fitting for ø1/4"	One-touch fitting for ø3/8"	SV3000
N9	One-touch fitting for ø5/16"		
N11	One-touch fitting for ø3/8"		
N9	One-touch fitting for ø5/16"	One-touch fitting for ø3/8"	SV4000
02N	NPT 1/4		
03N	NPT 3/8		
02T	NPTF 1/4	NPTF 3/8	
03T	NPTF 3/8		
M	A, B ports mixed		

Example 1: Tie-rod base

SS5V 1 - 10FD 1 - 05 U

Example 2: Cassette base

SS5V 1 - 16FD 1 - 05 U

Note 1) Double wiring specifications: Single, double, 3 position and 4 position solenoid valves can be used at all of the manifold stations. Use of a single solenoid will result in an unused control signal. If this is not desired, order with a specified layout.

Note 2) Specified layout: Indicate wiring specifications on the manifold specification sheet. (Note that double, 3 and 4 position valves cannot be used where single solenoid wiring has been specified.)

Note) In case of D0, only DIN rail fittings are attached.

How to Order Manifold Assembly

Ordering example (SV1000)

Manifold
SS5V1-16FD1-06B-C6 (1 set)

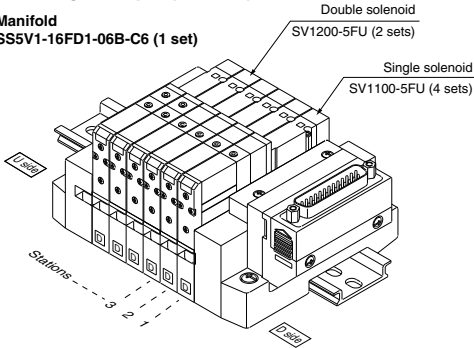

SS5V1-16FD1-06B-C6.....1 set (Manifold part no.)
* SV1100-5FU.....4 sets (Single solenoid part no.)
* SV1200-5FU.....2 sets (Double solenoid part no.)

How to Order Solenoid Valves

SV 1 1 00 - 5 F - [] - []

Series ●

1	SV1000
2	SV2000
3	SV3000
4	SV4000

Type of actuation ●

1	2 position single
2	2 position double
3	3 position closed center
4	3 position exhaust center
5	3 position pressure center
A	4 position dual 3 port valve: N.C./N.C.
B	4 position dual 3 port valve: N.O./N.O.
C	4 position dual 3 port valve: N.C./N.O.

* 4 position dual 3 port valves are applicable to Series SV1000 and SV2000 only.

Pilot type ●

Nil	Internal pilot
R	External pilot

* External pilot specifications is not available for 4 position dual 3 port valves.

Note) Available with manifold block for station additions. Refer to pages 625 and 631.

Made to Order ●

Nil	—
X90	Main valve fluororubber (Refer to page 646.)

Manual override

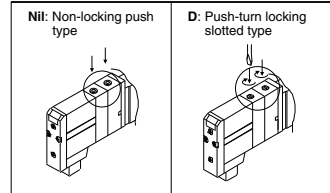

Light/Surge voltage suppressor

U	With light/surge voltage suppressor
R	With surge voltage suppressor

Rated voltage

5	24 VDC
6	12 VDC

Back pressure check valve

Nil	None
K	Built-in

* Built-in back pressure check valve type is applicable to series SV1000 only.

* Back pressure check valve is not available for 3 position valve.

Note) Refer to Specific Product Precautions 2 on page 648.

- SJ
- SY
- SY
- SV
- SYJ
- SZ
- VF
- VP4
- S0700
- VQ
- VQ4
- VQ5
- VQC
- VQC4
- VQZ
- SQ
- VFS
- VFR
- VQ7

Manifold Electrical Wiring

10F/16F D-sub Connector Type (25 pins)

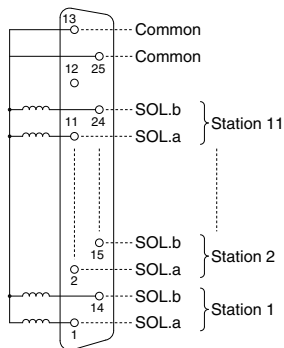

- This circuit has double wiring specifications for up to 11 stations. Since the usable number of solenoids differs depending on the manifold type, refer to the table below.
In the case of single solenoids, connect to SOL.A. Furthermore, when wiring is specified on the manifold specification sheet, connections are made without skipping any connectors, and signals A for single and A, B for double are in order 1 → 14 → 2 → 15, etc.
- Stations are counted from D side (connector side) as the 1st.
- Since solenoid valves do not have polarity, either the +COM or -COM can be used.

Usable No. of Solenoids

Model	Max. no. of solenoids
Tie-rod base type 10	23
Cassette base type 16	18
	23

Dimensions: Series SV1000 for D-sub Connector

● Cassette base manifold: SS5V1-16FD₂¹ Stations $\frac{U}{D}$ (S, R, RS)- C3, N1 C4, N3 C6, N7

- When P, E port outlets are indicated on the U side or D side, the P, E ports on the opposite side are plugged.
- External pilot port positions and silencer discharge port positions are the same as P, E port outlet positions.

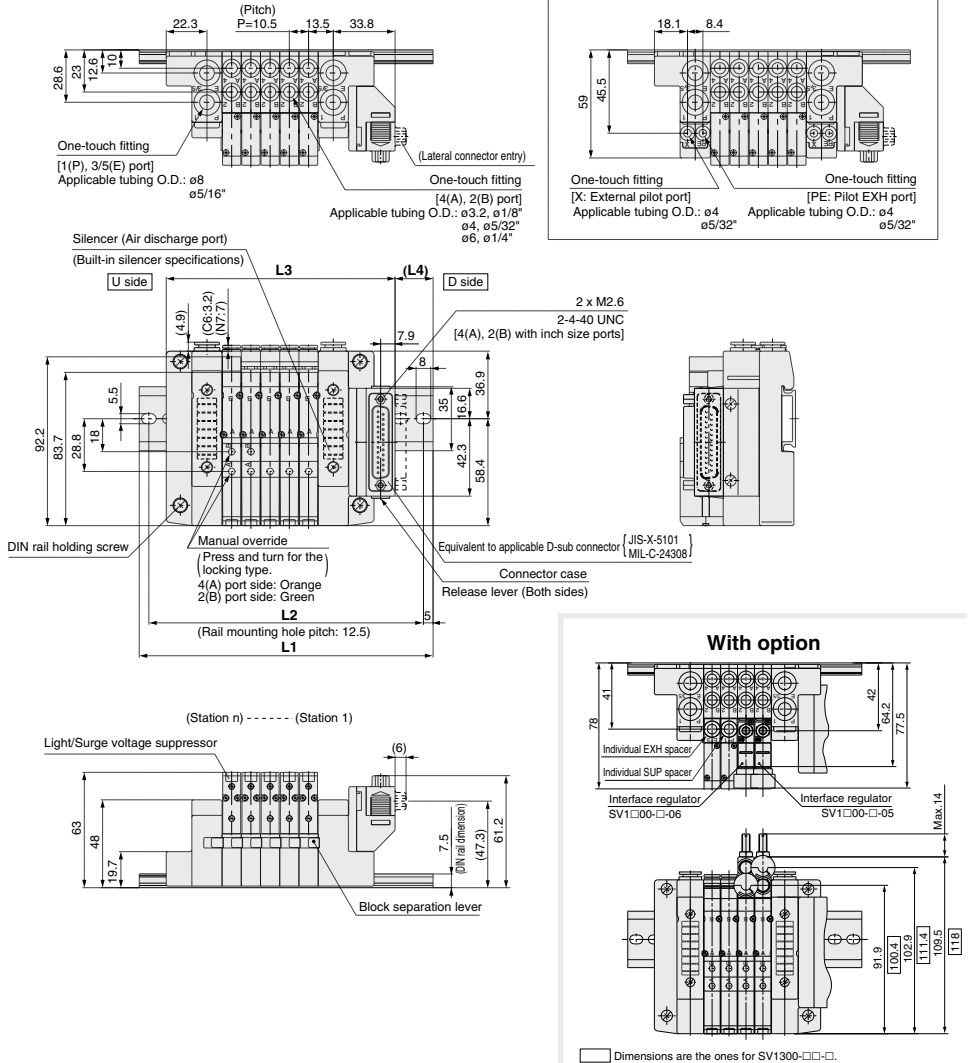

L Dimension

	n: Stations																
	2	3	4	5	6	7	8	9	10	11	12	13	14	15	16	17	18
L1	123	135.5	148	160.5	173	185.5	198	198	210.5	223	235.5	248	260.5	260.5	273	285.5	298
L2	112.5	125	137.5	150	162.5	175	187.5	187.5	200	212.5	225	237.5	250	250	262.5	275	287.5
L3	93.5	104	114.5	125	135.5	146	156.5	167	177.5	188	198.5	209	219.5	230	240.5	251	261.5
L4	18	19	20	21	22	23	24	18.5	19.5	20.5	21.5	22.5	23.5	18.5	19.5	20.5	21.5

SJ
SY
SY
SV
SYJ
SZ
VF
VP4
S0700
VQ
VQ4
VQ5
VQC
VQC4
VQZ
SQ
VFS
VFR
VQ7

Dimensions: Series SV2000 for D-sub Connector

● Cassette base manifold: SS5V2-16FD₂¹ Stations $\frac{U}{D}$ (S, R, RS)- C4, N3 C6, N7 C8, N9

- When P, E port outlets are indicated on the U side or D side, the P, E ports on the opposite side are plugged.
- External pilot port positions and silencer discharge port positions are the same as P, E port outlet positions.

With External Pilot Specifications

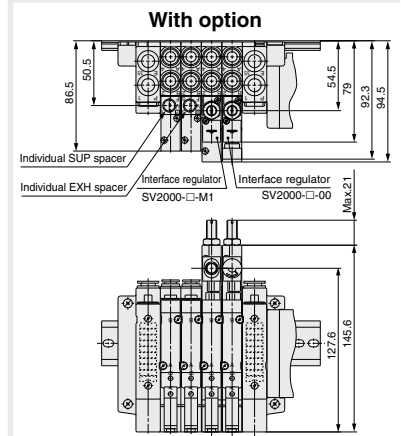
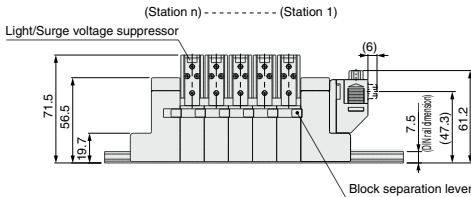
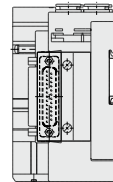
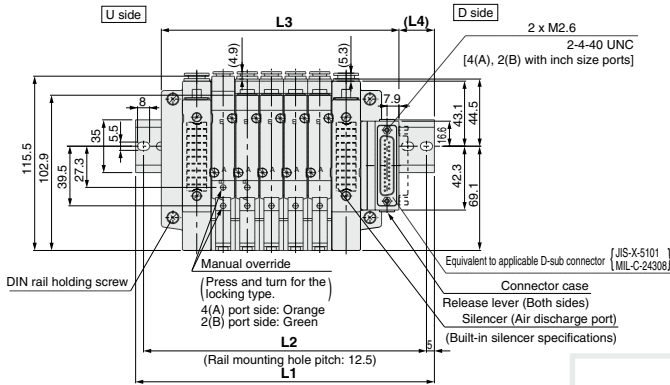
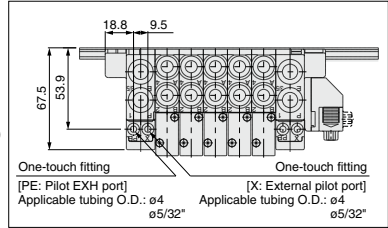
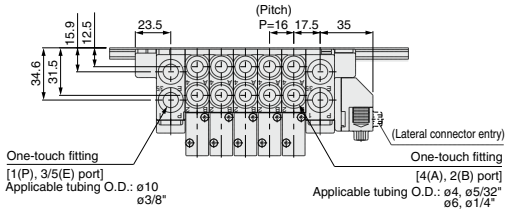

L Dimension

n	2	3	4	5	6	7	8	9	10	11	12	13	14	15	16	17	18	19	20
L1	148	160.5	173	198	210.5	223	235.5	260.5	273	285.5	310.5	323	335.5	348	373	385.5	398	423	435.5
L2	137.5	150	162.5	187.5	200	212.5	225	250	262.5	275	300	312.5	325	337.5	362.5	375	387.5	412.5	425
L3	109.5	125.5	141.5	157.5	173.5	189.5	205.5	221.5	237.5	253.5	269.5	285.5	301.5	317.5	333.5	349.5	365.5	381.5	397.5
L4	22.5	20.5	19	23.5	21.5	20	18	22.5	21	19	23.5	22	20	18.5	23	21	19.5	24	22

Dimensions: Series SV1000 for D-sub Connector

● Tie-rod base manifold: SS5V1-10FD₂ - (Stations) $\frac{U}{D}$ (S, R, RS) - C3, N1
C4, N3 (S, R, RS) - C6, N7 (-D)

- When P, E port outlets are indicated on the U side or D side, the P, E ports on the opposite side are plugged.
- External pilot port positions and silencer discharge port positions are the same as P, E port outlet positions.

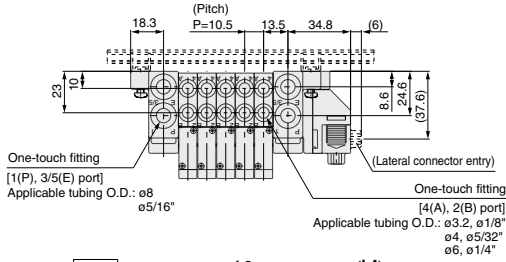

With External Pilot Specifications

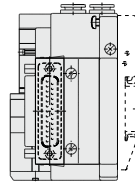
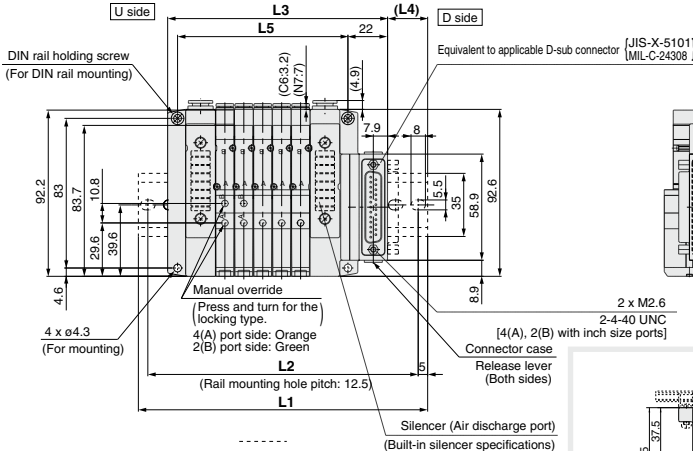
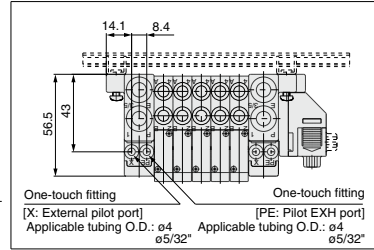

With option

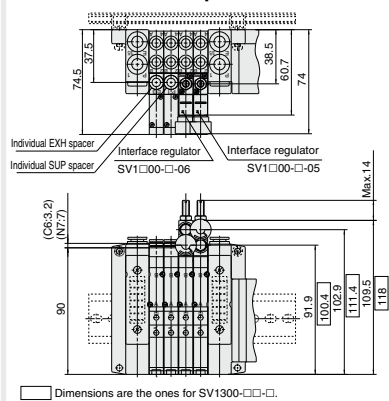

L Dimension

n	2	3	4	5	6	7	8	9	10	11	12	13	14	15	16	17	18	19	20
L1	123	135.5	148	160.5	173	173	185.5	198	210.5	223	235.5	235.5	248	260.5	273	285.5	298	310.5	310.5
L2	112.5	125	137.5	150	162.5	162.5	175	187.5	200	212.5	225	225	237.5	250	262.5	275	287.5	300	300
L3	90.5	101	111.5	122	132.5	143	153.5	164	174.5	185	195.5	206	216.5	227	237.5	248	258.5	269	279.5
L4	19.5	20.5	21.5	22.5	23.5	18	19	20	21	22	23	18	19	20	21	22	23	24	18.5
L5	63	73.5	84	94.5	105	115.5	126	136.5	147	157.5	168	178.9	189	199.5	210	220.5	231	241.5	252

n: Stations

- SJ
- SY
- SY
- SV**
- SYJ
- SZ
- VF
- VP4
- S0700
- VQ
- VQ4
- VQ5
- VQC
- VQC4
- VQZ
- SQ
- VFS
- VFR
- VQ7

Series SV

Dimensions: Series SV2000 for D-sub Connector

● Tie-rod base manifold: SS5V2-10FD₂¹ = $\left[\begin{matrix} \text{Stations} \\ \text{D} \end{matrix} \right] \begin{matrix} \text{U} \\ \text{B} \end{matrix} (\text{S, R, RS}) - \begin{matrix} \text{C4, N3} \\ \text{C6, N7} \\ \text{C8, N9} \end{matrix} (-\text{D})$

- When P, E port outlets are indicated on the U side or D side, the P, E ports on the opposite side are plugged.
- External pilot port positions and silencer discharge port positions are the same as P, E port outlet positions.

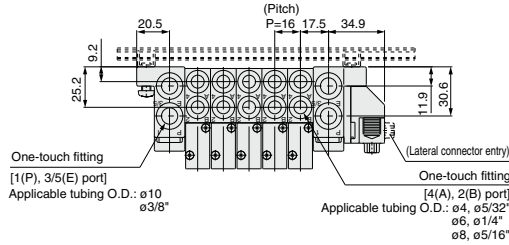

With External Pilot Specifications

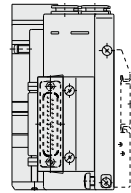
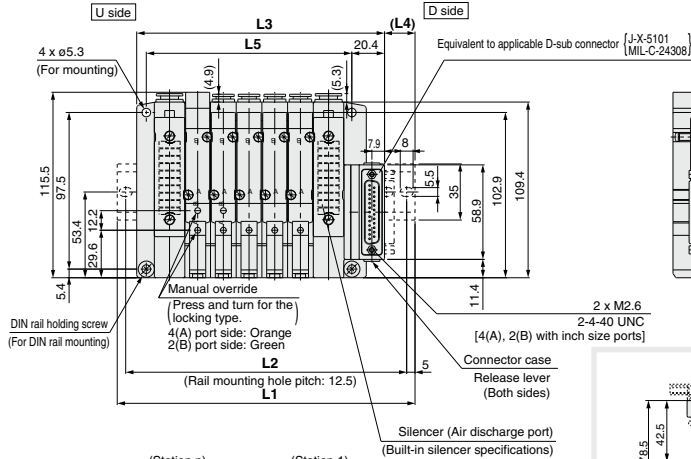
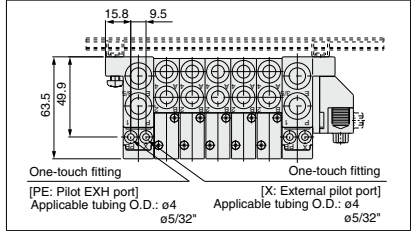

With option

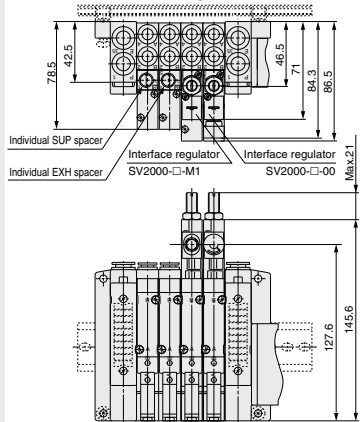

L Dimension

n	2	3	4	5	6	7	8	9	10	11	12	13	14	15	16	17	18	19	20
L1	135.5	160.5	173	185.5	210.5	223	235.5	248	273	285.5	298	323	335.5	348	360.5	385.5	398	410.5	435.5
L2	125	150	162.5	175	200	212.5	225	237.5	262.5	275	287.5	312.5	325	337.5	350	375	387.5	400	425
L3	106.4	122.4	138.4	154.4	170.4	186.4	202.4	218.4	234.4	250.4	266.4	282.4	298.4	314.4	330.4	346.4	362.4	378.4	394.4
L4	17.5	22	20.5	18.5	23	21.5	19.5	18	22.5	20.5	19	23.5	21.5	20	18	22.5	21	19	23.5
L5	80	96	112	128	144	160	176	192	208	224	240	256	272	288	304	320	336	352	368

Dimensions: Series SV3000 for D-sub Connector

● Tie-rod base manifold: SS5V3-10FD₂¹ = $\left[\begin{matrix} \text{Stations} \\ \text{U} \\ \text{D} \end{matrix} \right] (\text{S, R, RS}) - \begin{matrix} \text{C6, N7} \\ \text{C8, N9} \\ \text{C10, N11} \end{matrix} (-\text{D})$

- When P, E port outlets are indicated on the U side or D side, the P, E ports on the opposite side are plugged.
- External pilot port positions and silencer discharge port positions are the same as P, E port outlet positions.

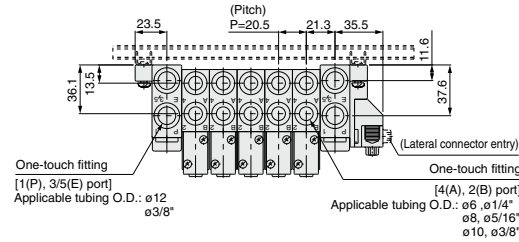

With External Pilot Specifications

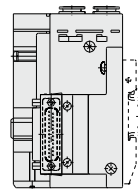
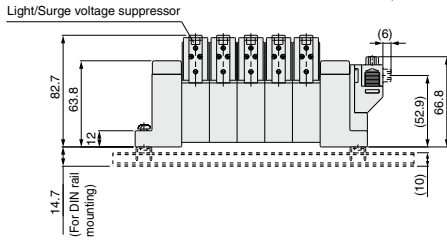
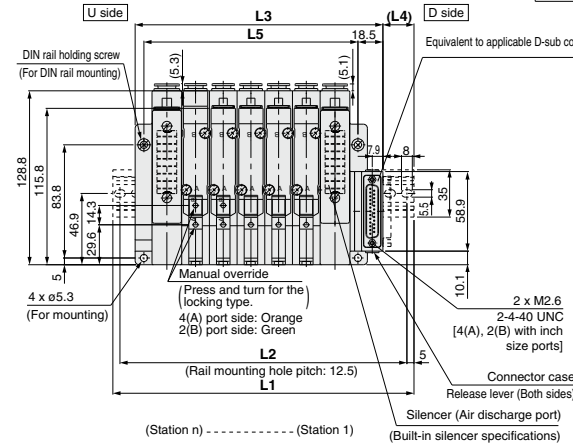
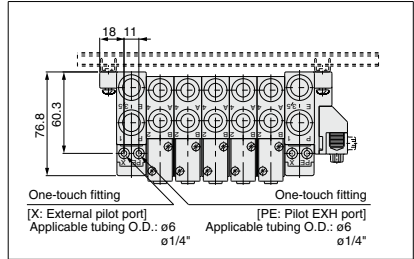

With option

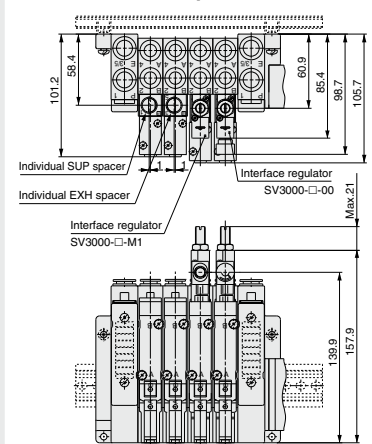

L Dimension

n	1	2	3	4	5	6	7	8	9	10	11	12	13	14	15	16	17	18	19	20
L1	160.5	173	198	223	235.5	260.5	285.5	298	323	348	360.5	385.5	398	423	448	460.5	485.5	510.5	523	
L2	150	162.5	187.5	212.5	225	250	275	287.5	312.5	337.5	350	375	387.5	412.5	437.5	450	475	500	512.5	
L3	122	142.5	163	183.5	204	224.5	245	265.5	286	306.5	327	347.5	368	388.5	409	429.5	450	470.5	491	
L4	22.5	18.5	20.5	23	19	21	23.5	19.5	21.5	24	20	22	18	20.5	22.5	18.5	21	23	19	
L5	97	117.5	138	158.5	179	199.5	220	240.5	261	281.5	302	322.5	343	363.5	384	404.5	425	445.5	466	

n: Stations

SJ
SY
SY
SV
SYJ
SZ
VF
VP4
S0700
VQ
VQ4
VQ5
VQC
VQC4
VQZ
SQ
VFS
VFR
VQ7

Series SV

Dimensions: Series SV4000 for D-sub Connector

● Tie-rod base manifold: SS5V4-10FD₂¹ - Stations $\frac{U}{D}$ (S, R, RS) - 02, C8, N9, C10, C12, N11 (-D)

- When P, E port outlets are indicated on the U side or D side, the P, E ports on the opposite side are plugged.
- External pilot port positions and silencer discharge port positions are the same as P, E port outlet positions.

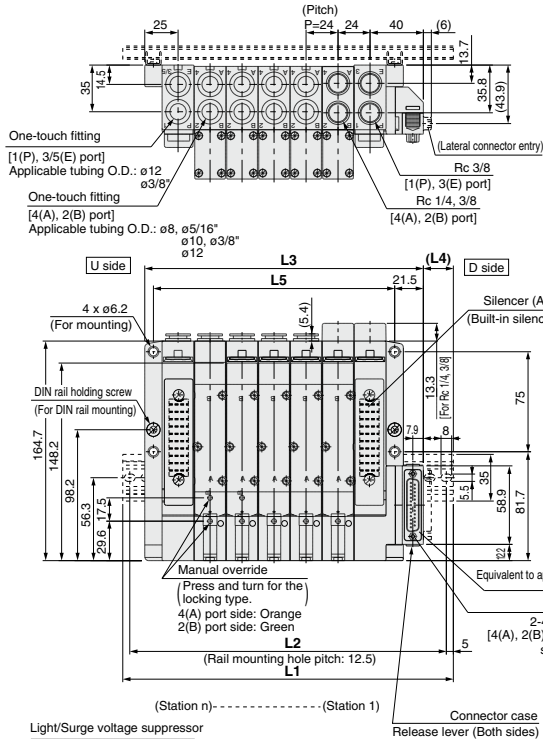

With External Pilot Specifications

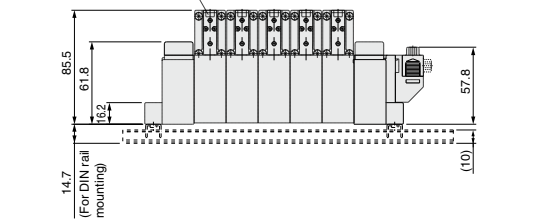
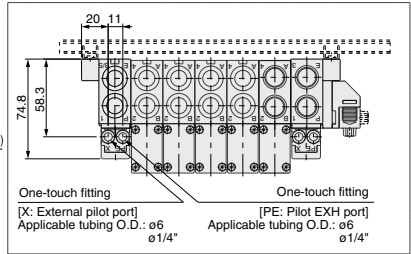

With option

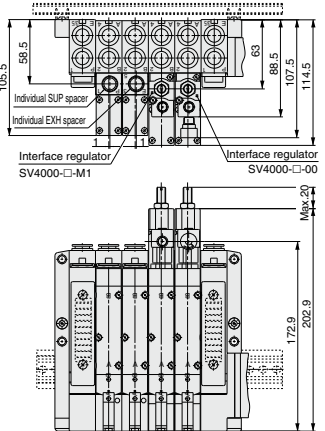

L Dimension

n	1	2	3	4	5	6	7	8	9	10	11	12	13	14	15	16	17	18	19	20
L1	173	198	223	248	273	298	310.5	335.5	360.5	385.5	410.5	435.5	460.5	485.5	510.5	535.5	560.5	585.5	610.5	
L2	162.5	187.5	212.5	237.5	262.5	287.5	300	325	350	375	400	425	450	475	500	525	550	575	600	
L3	137	161	185	209	233	257	281	305	329	353	377	401	425	449	473	497	521	545	569	
L4	21	21.5	22	22.5	23	23.5	18	18.5	19	19.5	20	20.5	21	21.5	22	22.5	23	23.5	24	
L5	109	133	157	181	205	229	253	277	301	325	349	373	397	421	445	469	493	517	541	

Flat Ribbon Cable Connector

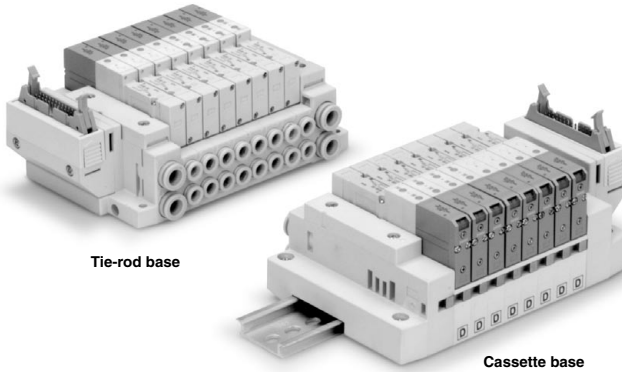

Tie-rod base

Cassette base

Applicable series

Cassette base manifold
SV1000/SV2000

Tie-rod base manifold
SV1000/SV2000/SV3000/SV4000

- Number of connectors: 26, 20, 10 pins
 - With strain relief
- Conforming to MIL-C-83503

SJ
SY
SY
SV
SYJ
SZ
VF
VP4
S0700
VQ
VQ4
VQ5
VQC
VQC4
VQZ
SQ
VFS
VFR
VQ7

Flat Ribbon Cable Connector Series SV



How to Order Manifold

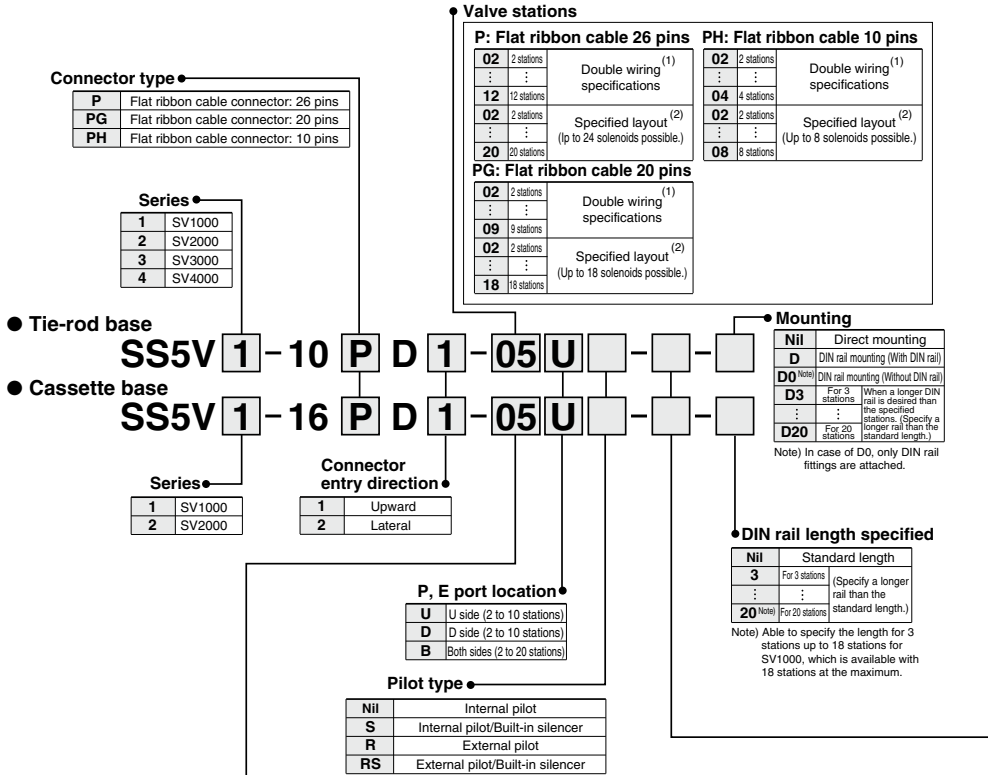

Valve stations • Series SV1000

P: Flat ribbon cable 26 pins	PH: Flat ribbon cable 10 pins
02 2 stations : : : : 09 9 stations : : : : 02 2 stations : : : : 18 18 stations	Double wiring (1) specifications Specified layout (2) (Up to 18 solenoids possible.) Double wiring (1) specifications Specified layout (2) (Up to 8 solenoids possible.)
PG: Flat ribbon cable 20 pins	
02 2 stations : : : : 09 9 stations : : : : 02 2 stations : : : : 18 18 stations	Double wiring (1) specifications Specified layout (2) (Up to 18 solenoids possible.)

Note 1) Double wiring specifications: Single, double, 3 and 4 position solenoid valves can be used on all manifold stations. Use of a single solenoid will result in an unused control signal. If this is not desired, order with a specified layout.

Series SV2000

P: Flat ribbon cable 26 pins	PH: Flat ribbon cable 10 pins
02 2 stations : : : : 12 12 stations : : : : 02 2 stations : : : : 20 20 stations	Double wiring (1) specifications Specified layout (2) (Up to 24 solenoids possible.) Double wiring (1) specifications Specified layout (2) (Up to 8 solenoids possible.)
PG: Flat ribbon cable 20 pins	
02 2 stations : : : : 09 9 stations : : : : 02 2 stations : : : : 18 18 stations	Double wiring (1) specifications Specified layout (2) (Up to 18 solenoids possible.)

Note 2) Specified layout: Indicate wiring specifications on a manifold specification sheet. (Note that double, 3 and 4 position valves cannot be used where single solenoid wiring has been specified.)

How to Order Valve Manifold Assembly

Ordering example (SV1000)

Manifold
SS5V1-16PD1-06B-C6 (1 set)

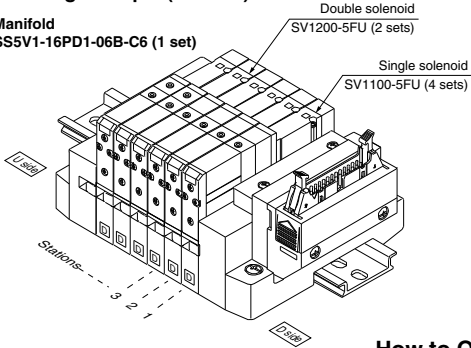

SS5V1-16PD1-06B-C6.....1 set (manifold part no.)
* SV1100-5FU.....4 sets (Single solenoid part no.)
* SV1200-5FU.....2 sets (Double solenoid part no.)

How to Order Valve

SV 1 1 0 0 - 5 F

Series

1	SV1000
2	SV2000
3	SV3000
4	SV4000

Type of actuation

1	2 position single
2	2 position double
3	3 position closed center
4	3 position exhaust center
5	3 position pressure center
A	4 position dual 3 port valve: N.C./N.C.
B	4 position dual 3 port valve: N.O./N.O.
C	4 position dual 3 port valve: N.C./N.O.

* 4 position dual 3 port valves are applicable to Series SV1000 and SV2000 only.

Pilot type

Nil	Internal pilot
R	External pilot

* External pilot specifications is not available for 4 position dual 3 port valves.

Rated voltage

5	24 VDC
6	12 VDC

Back pressure check valve

Nil	None
K	Built-in

* Built-in back pressure check valve type is applicable to series SV1000 only.
* Back pressure check valve is not available for 3 position valve.

Note) Refer to Specific Product Precautions 2 on page 648.

Note) Available with manifold block for station additions. Refer to pages 625 and 631.

Made to Order

Nil	—
X90	Main valve fluororubber (Refer to page 646.)

Manual override

Nil: Non-locking push type

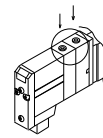

D: Push-turn locking slotted type

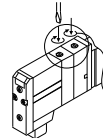

Light/Surge voltage suppressor

U	With light/surge voltage suppressor
R	With surge voltage suppressor

A, B port size (Metric)

Symbol	A, B port	P, E port	Applicable series
C3	One-touch fitting for ø3/2	One-touch fitting for ø6	SV1000
C4	One-touch fitting for ø4		
C6	One-touch fitting for ø6	One-touch fitting for ø10	SV2000
C4	One-touch fitting for ø4		
C6	One-touch fitting for ø6	One-touch fitting for ø12	SV3000
C8	One-touch fitting for ø8		
C6	One-touch fitting for ø6	One-touch fitting for ø12	SV4000
C8	One-touch fitting for ø8		
C10	One-touch fitting for ø10	Rc 3/8	SV4000
C8	One-touch fitting for ø8		
C10	One-touch fitting for ø10	G 3/8	SV4000
C12	One-touch fitting for ø12		
02	Rc 1/4	G 3/8	SV4000
03	Rc 3/8		
02F	G 1/4	G 3/8	SV4000
03F	G 3/8		
M	A, B ports mixed		

A, B port size (Inch)

Symbol	A, B port	P, E port	Applicable series
N1	One-touch fitting for ø1/8"	One-touch fitting for ø5/16"	SV1000
N3	One-touch fitting for ø5/32"		
N7	One-touch fitting for ø1/4"	One-touch fitting for ø3/8"	SV2000
N3	One-touch fitting for ø5/32"		
N7	One-touch fitting for ø1/4"	One-touch fitting for ø3/8"	SV3000
N9	One-touch fitting for ø5/16"		
N7	One-touch fitting for ø1/4"	One-touch fitting for ø3/8"	SV4000
N9	One-touch fitting for ø5/16"		
N11	One-touch fitting for ø3/8"	NPT 3/8	SV4000
N9	One-touch fitting for ø5/16"		
N11	One-touch fitting for ø3/8"	NPTF 3/8	SV4000
02N	NPT 1/4		
03N	NPT 3/8		
02T	NPTF 1/4		
03T	NPTF 3/8		
M	A, B ports mixed		

* In the case of mixed specifications (M), indicate separately on the manifold specification sheet.

* Port sizes of X, PE port for external pilot specification (R, RS) are ø4 (metric), ø5/32" (inch) for SV1000/2000 and ø6 (metric) and ø1/4" (inch) for SV3000/4000.

SV
SVJ
SZ
VF
VP4
S0700
VQ
VQ4
VQ5
VQC
VQC4
VQZ
SQ
VFS
VFR
VQ7

Flat Ribbon Cable PC Wiring Series SV



How to Order Manifold

● Tie-rod base

SS5V

1

 - 10GD

1

 - 05 U

--

 -

--

 -

--

 -

--

● Cassette base

SS5V

1

 - 16GD

1

 - 05 U

--

 -

--

 -

--

 -

--

Series

1	SV1000
2	SV2000

Connector entry direction

1	Upward
2	Lateral

● Valve stations

Symbol	Stations	Note
02	2 stations	Double wiring ⁽¹⁾ specifications
⋮	⋮	
08	8 stations	Specified layout ⁽²⁾ (up to 16 solenoids possible.)
02	2 stations	
⋮	⋮	
16	16 stations	

Note1) Double wiring specifications: Single, double, 3 position and 4 position solenoid valves can be used on all manifold stations. Use of a single solenoid will result in an unused control signal. If this is not desired, order with a specified layout.

Note2) Specified layout: Indicate wiring specifications on the manifold specification sheet. (Note that double, 3 position and 4 position valves cannot be used where single solenoid wiring has been specified.)

● P, E port location

U	U side (2 to 10 stations)
D	D side (2 to 10 stations)
B	Both sides (2 to 16 stations)

● SUP/EXH block assembly specifications

Nil	Internal pilot
S ^{Note}	Internal pilot/Built-in silencer
R	External pilot
RS ^{Note}	External pilot/Built-in silencer

Note) When the built-in silencer type is used, keep the exhaust port from coming in direct contact with water or other liquids.

● Mounting

Nil	Direct mounting
D	DIN rail mounting (With DIN rail)
D0 ^{Note}	DIN rail mounting (Without DIN rail)
D3	For 3 stations
⋮	⋮
D16	For 16 stations

Note) In the case of D0, only DIN rail fittings are attached.

● DIN rail length specified

Nil	Standard length
3	For 3 stations
⋮	⋮
16	For 16 stations

● A, B port size (metric)

Symbol	A, B port	P, E port	Applicable series
C3	One-touch fitting for ø3.2	One-touch fitting for ø8	SV1000
C4	One-touch fitting for ø6		
C4	One-touch fitting for ø4	One-touch fitting for ø10	SV2000
C6	One-touch fitting for ø6		
C8	One-touch fitting for ø8	One-touch fitting ø12	SV3000
C6	One-touch fitting for ø6		
C10	One-touch fitting for ø10	One-touch fitting ø12	SV4000
C8	One-touch fitting for ø8		
C10	One-touch fitting for ø10	Rc 3/8	
C12	One-touch fitting for ø12		
02	Rc 1/4	G 3/8	
03	Rc3/8		
02F	G 1/4	G 3/8	
03F	G 3/8		
M	A, B ports mixed		

● A, B port size (inch)

Symbol	A, B port	P, E port	Applicable series
N1	One-touch fitting for ø1/8"	One-touch fitting for ø5/16"	SV1000
N3	One-touch fitting for ø5/32"		
N7	One-touch fitting for ø1/4"	One-touch fitting for ø3/8"	SV2000
N3	One-touch fitting for ø5/32"		
N7	One-touch fitting for ø1/4"	One-touch fitting for ø3/8"	SV3000
N9	One-touch fitting for ø5/16"		
N7	One-touch fitting for ø1/4"	One-touch fitting for ø3/8"	SV4000
N9	One-touch fitting for ø5/16"		
N11	One-touch fitting for ø3/8"	NPTF 3/8	
N11	One-touch fitting for ø3/8"		
02N	NPT 1/4	NPTF 3/8	
03N	NPT 3/8		
02T	NPTF 1/4	NPTF 3/8	
03T	NPTF 3/8		
M	A, B ports mixed		

* In the case of mixed specifications (M), indicate separately on the manifold specification sheet.

* Port sizes of X, PE port for external pilot specification (R, RS) are ø4 (metric), ø5/32" (inch) for SV1000/2000 and ø6 (metric) and ø1/4" (inch) for SV3000/4000.

How to Order Valve

SV **1** **1** 00 - **5** F -

● **Series**

1	SV1000
2	SV2000
3	SV3000
4	SV4000

● **Type of actuation**

1	2 position single
2	2 position double
3	3 position closed center
4	3 position exhaust center
5	3 position pressure center
A	4 position dual 3 port valve: N.C./N.C.
B	4 position dual 3 port valve: N.O./N.O.
C	4 position dual 3 port valve: N.C./N.O.

* 4 position dual 3 port valves are applicable to Series SV1000 and SV2000 only.

● **Pilot type**

Nil	Internal pilot
R	External pilot

* External pilot specifications is not available for 4 position dual 3 port valves.

● **Made to Order**

Nil	—
X90	Main valve fluoro rubber (Refer to page 646.)

● **Manual override**

Nil	Non-locking push type
D	Push-turn locking slotted type

● **Light/Surge voltage suppressor**

U	With light/surge voltage suppressor
R	With surge voltage suppressor

● **Rated voltage**

5	24 VDC
---	--------

● **Back pressure check valve**

Nil	None
K	Built-in

* Built-in back pressure check valve type is applicable to series SV1000 only.

* Back pressure check valve is not available for 3 position valve.

SJ
SY
SY
SV
SYJ
SZ
VF
VP4
S0700
VQ
VQ4
VQ5
VQC
VQC4
VQZ
SQ
VFS
VFR
VQ7

Manifold Electrical Wiring

10P/16P Flat Ribbon Cable Type (26 pins)

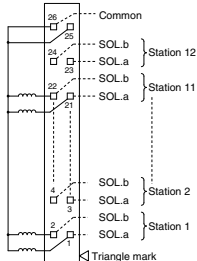

- This circuit has double wiring specifications for up to 12 stations. Since the usable number of solenoids differs depending on the manifold type, refer to the table below. In the case of single solenoids, connect to SOL. A. Furthermore, when wiring is specified on a manifold specification sheet, connections are made without skipping any connectors, and connections are made without skipping any connectors, and signals A for single and A, B for double are in order 1 → 2 → 3 → 4, etc.
- Stations are counted from D side (connector side) as the 1st one.
- Since terminal numbers are not indicated on the flat cable, use the triangle mark as a reference for wiring.
- Since solenoid valves do not have polarity, either the +COM or -COM can be used.

Usable No. of Solenoids

Model		Max. no. of solenoids
Tie-rod base type 10	SV1000 to SV4000	24
Cassette base type 16	SV1000	18
	SV2000	24

10PG/16PG Flat Ribbon Cable Type (20 pins)

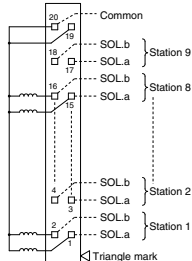

- This circuit has double wiring specifications for up to 9 stations. Since the usable number of solenoids differs depending on the manifold type, refer to the table below. In the case of single solenoids, connect to SOL. A. Furthermore, when wiring is specified on a manifold specification sheet, connections are made without skipping any connectors, and connections are made without skipping any connectors, and signals A for single and A, B for double are in order 1 → 2 → 3 → 4, etc.
- Stations are counted from D side (connector side) as the 1st one.
- Since terminal numbers are not indicated on the flat cable, use the triangle mark as a reference for wiring.
- Since solenoid valves do not have polarity, either the +COM or -COM can be used.

Usable No. of Solenoids

Model		Max. no. of solenoids
Tie-rod base type 10	SV1000 to SV4000	18
Cassette base type 16	SV1000	
	SV2000	

10PH/16PH Flat Ribbon Cable Type (10 pins)

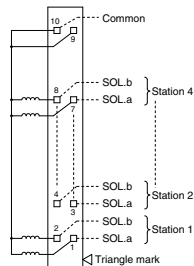

- This circuit has double wiring specifications for up to 4 stations. Since the usable number of solenoids differs depending on the manifold type, refer to the table below. In the case of single solenoids, connect to SOL. A. Furthermore, when wiring is specified on a manifold specification sheet, connections are made without skipping any connectors, connections are made without skipping any connectors, and signals A for single and A, B for double are in order 1 → 2 → 3 → 4, etc.
- Stations are counted from D side (connector side) as the 1st one.
- Since terminal numbers are not indicated on the flat cable, use the triangle mark as a reference for wiring.
- Since solenoid valves do not have polarity, either the +COM or -COM can be used.

Usable No. of Solenoids

Model		Max. no. of solenoids
Tie-rod base type 10	SV1000 to SV4000	8
Cassette base type 16	SV1000	
	SV2000	

10GD/16GD Flat Ribbon Cable Type (PC Wiring)

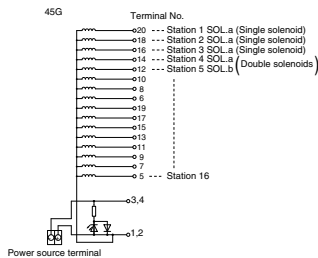

- This circuit has double wiring specifications for up to 8 stations. Since the usable number of solenoids differs depending on the manifold type, refer to the table below. In the case of single solenoids, connect to SOL. A. Furthermore, when wiring is specified on a manifold specification sheet, connections are made without skipping any connectors, connections are made without skipping any connectors, and signals A for single and A, B for double are in order 20 → 18 → 16 → 14, etc.
- Stations are counted from D side (connector side) as the 1st one.
- Since terminal numbers are not indicated on the flat cable, use the triangle mark as a reference for wiring.
- Since solenoid valves do not have polarity, either the +COM or -COM can be used.

Usable No. of Solenoids

Model		Max. no. of solenoids
Tie-rod base type 10	SV1000 to SV4000	16
Cassette base type 16	SV1000	
	SV2000	

Dimensions: Series SV1000 for Flat Ribbon Cable

● Cassette base manifold : SS5V1-16^P_{PH} D₂ - [Stations]_B (S, R, RS) C_{3, N1} - C_{4, N3} C_{6, N7}

- When P, E port outlets are indicated on the U side or D side, the P, E ports on the opposite side are plugged.
- External pilot port positions and silencer discharge port positions are the same as P, E port outlet positions.

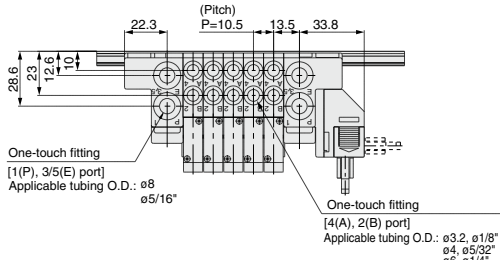

With External Pilot Specifications

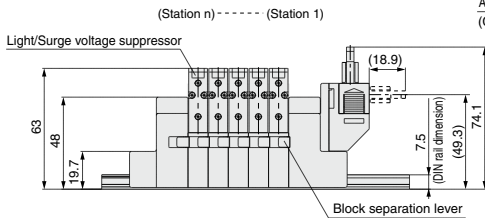
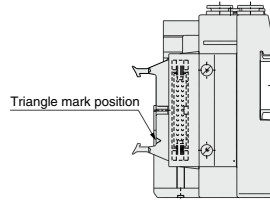
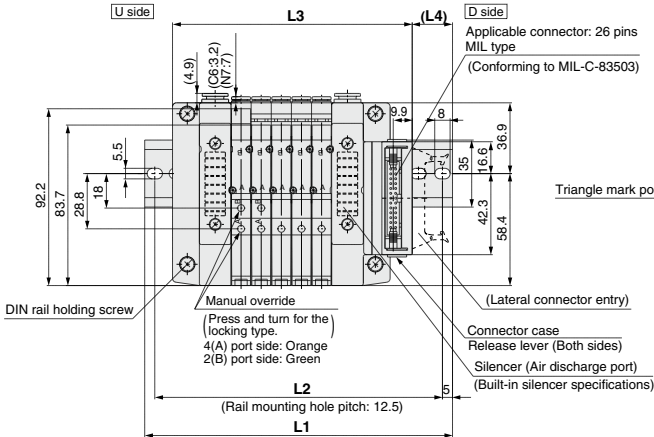
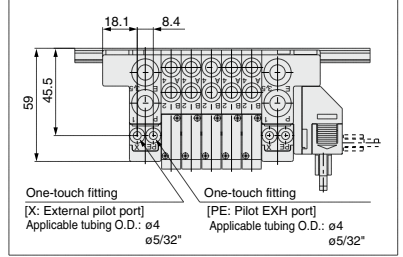

Applicable connector: 20 pins MIL type (Conforming to MIL-C-83503)

Applicable connector: 10 pins MIL type (Conforming to MIL-C-83503)

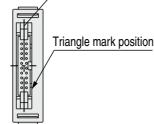

16PG (20 pins)

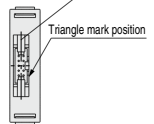

16PH (10 pins)

Refer to page 597 (compliant for D-sub connector) for dimensions with interface regulator and individual SUP/EXH spacer.

L Dimension

	n : Stations																
n	2	3	4	5	6	7	8	9	10	11	12	13	14	15	16	17	18
L1	135.5	135.5	148	160.5	173	185.5	198	198	210.5	223	235.5	248	260.5	260.5	273	285.5	298
L2	125	125	137.5	150	162.5	175	187.5	187.5	200	212.5	225	237.5	250	250	262.5	275	287.5
L3	93.5	104	114.5	125	135.5	146	156.5	167	177.5	188	198.5	209	219.5	230	240.5	251	261.5
L4	24.5	19	20	21	22	23	24	19	20	21	22	23	24	18.5	19.5	20.5	21.5

SV
SVJ
SZ
VF
VP4
S0700
VQ
VQ4
VQ5
VQC
VQC4
VQZ
SQ
VFS
VFR
VQ7

Series SV

Dimensions: Series SV2000 for Flat Ribbon Cable

● Cassette base manifold : SS5V2-16 ^P _{PH} D₂ - [Stations] _B (S, R, RS) ^{C4, N3} _{C6, N7} ^{C8, N8}

- When P, E port outlets are indicated on the U side or D side, the P, E ports on the opposite side are plugged.
- External pilot port positions and silencer discharge port positions are the same as P, E port outlet positions.

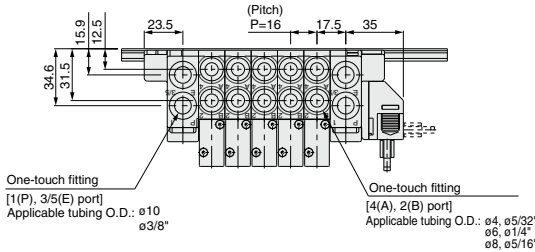

With External Pilot Specifications

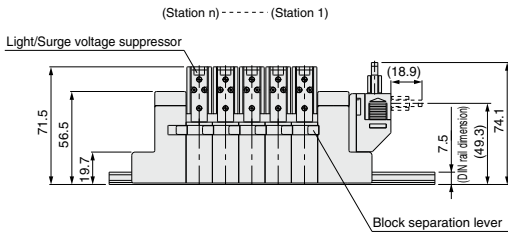
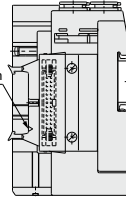
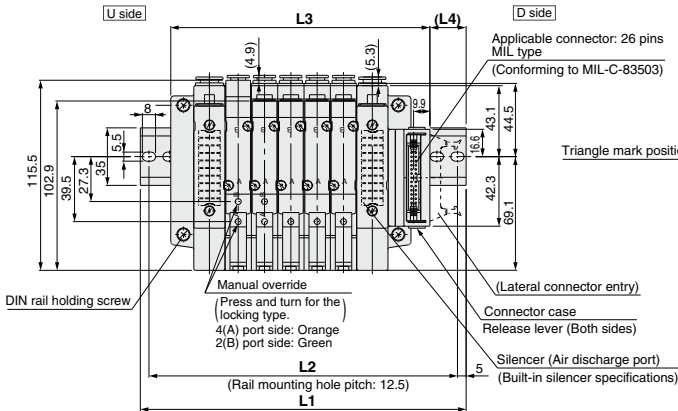
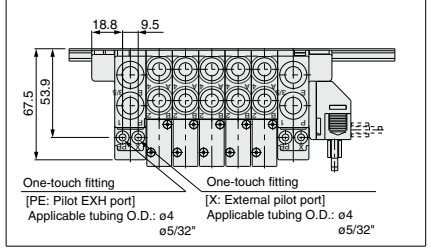

Applicable connector: 20 pins MIL type (Conforming to MIL-C-83503)

Applicable connector: 10 pins MIL type (Conforming to MIL-C-83503)

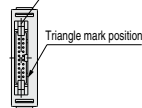

16PG (20 pins)

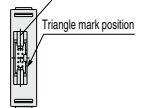

16PH (10 pins)

Refer to page 597 (compliant for D-sub connector) for dimensions with interface regulator and individual SUP/EXH spacer.

L Dimension

n	2	3	4	5	6	7	8	9	10	11	12	13	14	15	16	17	18	19	20
L1	148	160.5	173	198	210.5	223	235.5	260.5	273	285.5	310.5	323	335.5	348	373	385.5	398	423	435.5
L2	137.5	150	162.5	187.5	200	212.5	225	250	262.5	275	300	312.5	325	337.5	362.5	375	387.5	412.5	425
L3	109.5	125.5	141.5	157.5	173.5	189.5	205.5	221.5	237.5	253.5	269.5	285.5	301.5	317.5	333.5	349.5	365.5	381.5	397.5
L4	22.5	21	19	23.5	22	20	18.5	23	21	19.5	24	22	20.5	18.5	23	21.5	19.5	24	22.5

Dimensions: Series SV1000 for Flat Ribbon Cable

● Tie-rod base manifold : SS5V1-10^P_{PH} D₂ - [Stations]_B (S, R, RS)^{C3, N1}_{C4, N3} (-D)

- When P, E port outlets are indicated on the U side or D side, the P, E ports on the opposite side are plugged.
- External pilot port positions and silencer discharge port positions are the same as P, E port outlet positions.

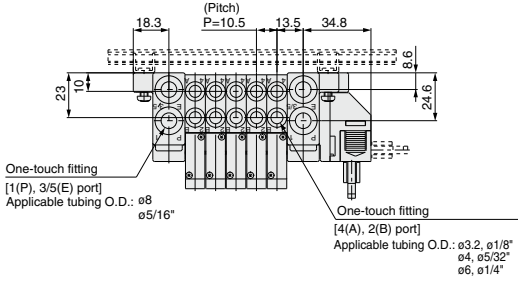

With External Pilot Specifications

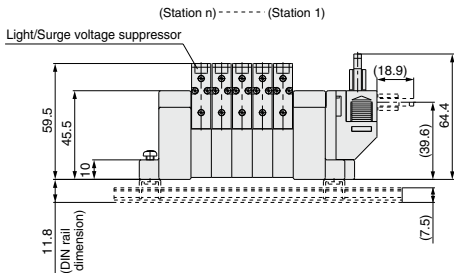
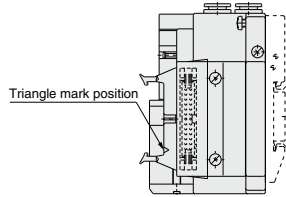
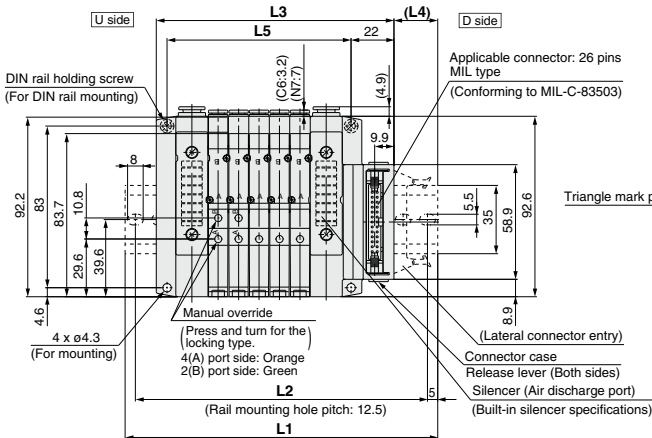
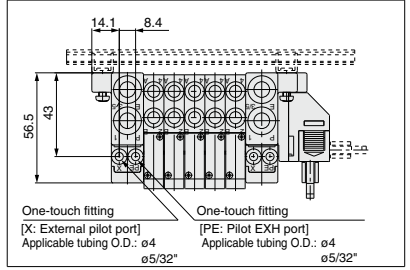

Applicable connector: 20 pins MIL type (Conforming to MIL-C-83503) Applicable connector: 10 pins MIL type (Conforming to MIL-C-83503)

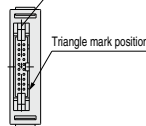

10PG (20 pins)

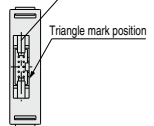

10PH (10 pins)

Refer to page 597 (compliant for D-sub connector) for dimensions with interface regulator and individual SUP/EXH spacer.

L Dimension

n	2	3	4	5	6	7	8	9	10	11	12	13	14	15	16	17	18	19	20
L1	123	135.5	148	160.5	173	173	185.5	198	210.5	223	235.5	248	248	260.5	273	285.5	298	310.5	310.5
L2	112.5	125	137.5	150	162.5	162.5	175	187.5	200	212.5	225	237.5	237.5	250	262.5	275	287.5	300	300
L3	90.5	101	111.5	122	132.5	143	153.5	164	174.5	185	195.5	206	216.5	227	237.5	248	258.5	269	279.5
L4	19.5	20.5	21.5	22.5	23.5	23.5	24.5	25.5	26.5	27.5	28.5	29.5	30.5	31.5	32.5	33.5	34.5	35.5	36.5
L5	63	73.5	84	94.5	105	115.5	126	136.5	147	157.5	168	178.5	189	199.5	210	220.5	231	241.5	252

n : Stations

- SV
- SVJ
- SZ
- VF
- VP4
- S0700
- VQ
- VQ4
- VQ5
- VQC
- VQC4
- VQZ
- SQ
- VFS
- VFR
- VQ7

Series SV

Dimensions: Series SV2000 for Flat Ribbon Cable

● Tie-rod base manifold : SS5V2-10 ^P PG D₂ - [Stations] _B (S, R, RS) ^{C4, N3} - ^{C6, N7} (-D)

- When P, E port outlets are indicated on the U side or D side, the P, E ports on the opposite side are plugged.
- External pilot port positions and silencer discharge port positions are the same as P, E port outlet positions.

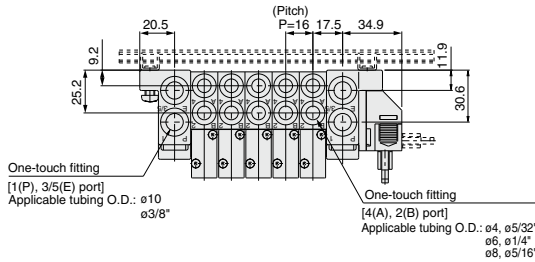

With External Pilot Specifications

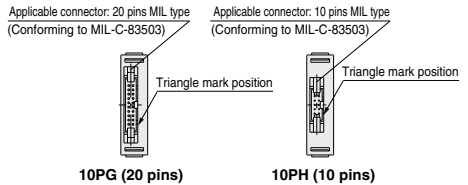
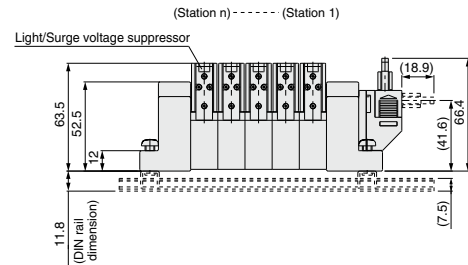
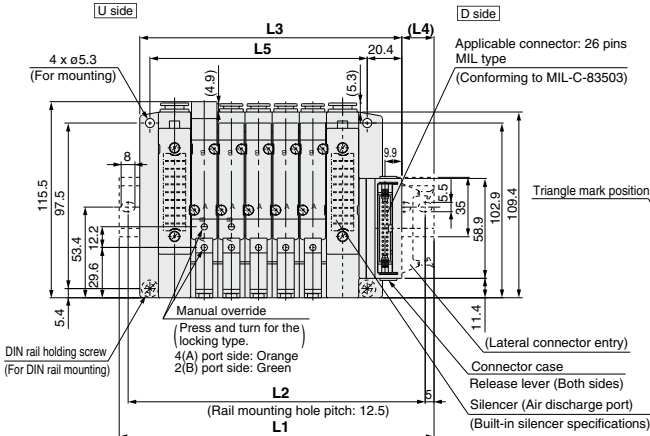
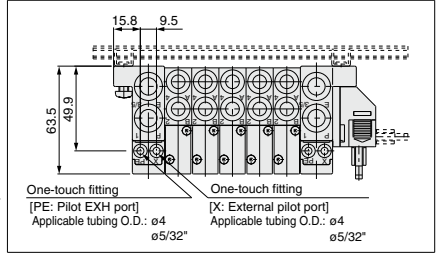

Refer to page 600 (compliant for D-sub connector) for dimensions with interface regulator and individual SUP/EXH spacer.

L Dimension

L	n : Stations																			
	1	2	3	4	5	6	7	8	9	10	11	12	13	14	15	16	17	18	19	20
L1	148	160.5	173	185.5	210.5	223	235.5	248	273	285.5	298	323	335.5	348	360.5	385.5	398	410.5	435.5	
L2	137.5	150	162.5	175	200	212.5	225	237.5	262.5	275	287.5	312.5	325	337.5	350	375	387.5	400	425	
L3	106.4	122.4	138.4	154.4	170.4	186.4	202.4	218.4	234.4	250.4	266.4	282.4	298.4	314.4	330.4	346.4	362.4	378.4	394.4	
L4	24	22.5	20.5	19	23.5	21.5	20	18	22.5	21	19	23.5	22	20	18.5	23	21	19.5	24	
L5	80	96	112	128	144	160	176	192	208	224	240	256	272	288	304	320	336	352	368	

Dimensions: Series SV3000 for Flat Ribbon Cable

● Tie-rod base manifold : SS5V3-10 ^P _{PH} D_2 - [Stations] _B (S, R, RS) ^{C6, N7} _{C10, N11} (-D)

- When P, E port outlets are indicated on the U side or D side, the P, E ports on the opposite side are plugged.
- External pilot port positions and silencer discharge port positions are the same as P, E port outlet positions.

With External Pilot Specifications

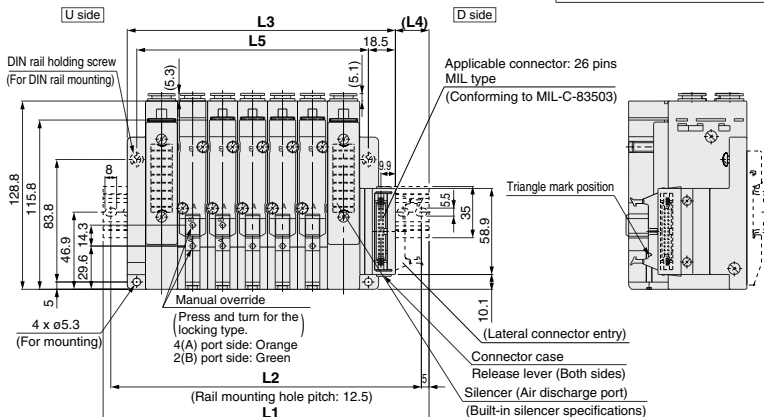
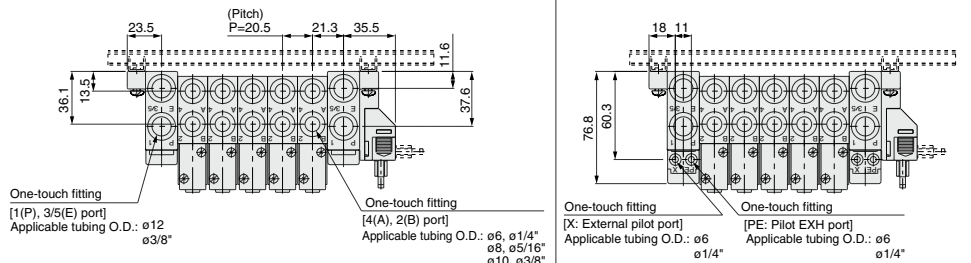

(Station n) - - - - - (Station 1)

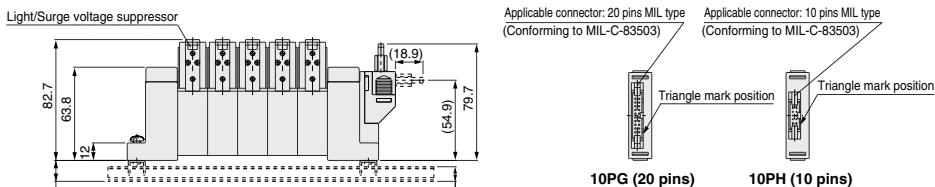

Refer to page 601 (compliant for D-sub connector) for dimensions with interface regulator and individual SUP/EXH spacer.

L Dimension

_n	1	2	3	4	5	6	7	8	9	10	11	12	13	14	15	16	17	18	19	20
L1	160.5	173	198	223	235.5	260.5	285.5	298	323	348	360.5	385.5	398	423	448	460.5	485.5	510.5	523	
L2	150	162.5	187.5	212.5	225	250	275	287.5	312.5	337.5	350	375	387.5	412.5	437.5	450	475	500	512.5	
L3	122	142.5	163	183.5	204	224.5	245	265.5	286	306.5	327	347.5	368	388.5	409	429.5	450	470.5	491	
L4	22.5	18.5	21	23	19	21.5	23.5	19.5	22	24	20	22.5	18.5	20.5	23	19	21	23.5	19.5	
L5	97	117.5	138	158.5	179	199.5	220	240.5	261	281.5	302	322.5	343	363.5	384	404.5	425	445.5	466	

n : Stations

SV
SVJ
SZ
VF
VP4
S0700
VQ
VQ4
VQ5
VQC
VQC4
VQZ
SQ
VFS
VFR
VQ7

Series SV

Dimensions: Series SV4000 for Flat Ribbon Cable

● Tie-rod base manifold : SS5V4-10^P_{PH} D₂ - [Stations]_B (S, R, RS) $\frac{65, C8, N9, C10, C12}{}$ (-D)

- When P, E port outlets are indicated on the U side or D side, the P, E ports on the opposite side are plugged.
- External pilot port positions and silencer discharge port positions are the same as P, E port outlet positions.

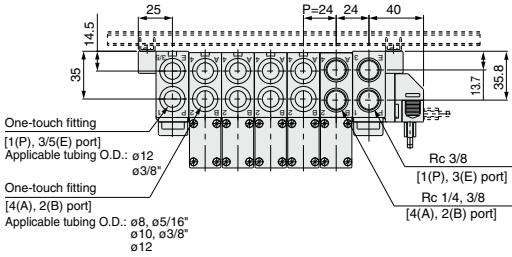

With External Pilot Specifications

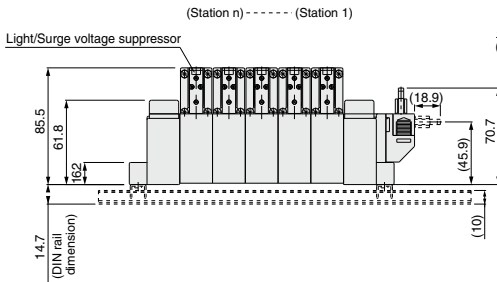
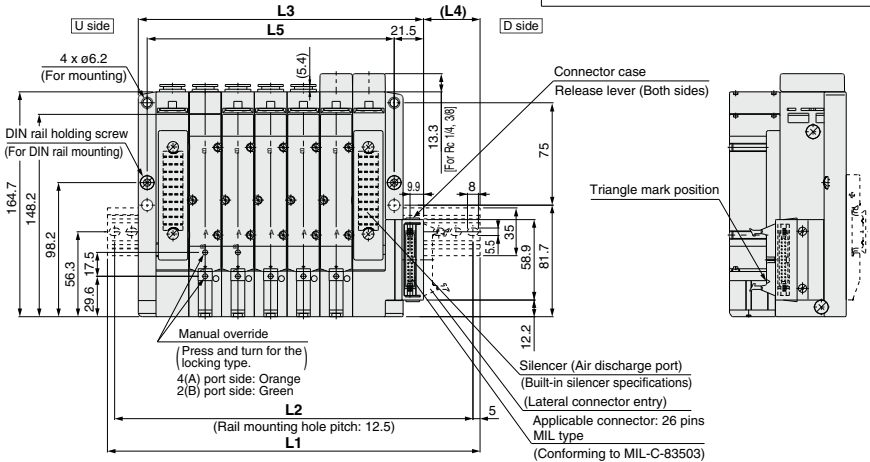
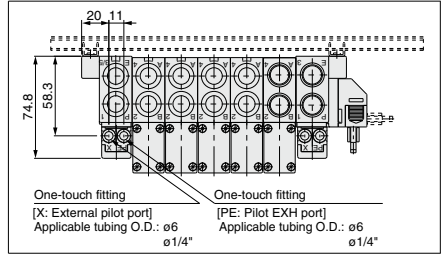

Applicable connector: 20 pins MIL type (Conforming to MIL-C-83503)

Applicable connector: 10 pins MIL type (Conforming to MIL-C-83503)

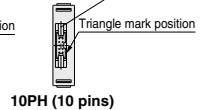
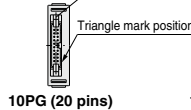

Refer to page 602 (compliant for D-sub connector) for dimensions with interface regulator and individual SUP/EXH spacer.

L Dimension

n	2	3	4	5	6	7	8	9	10	11	12	13	14	15	16	17	18	19	20
L1	185.5	210.5	235.5	260.5	285.5	310.5	335.5	348	373	398	423	448	473	498	523	548	573	598	623
L2	175	200	225	250	275	300	325	337.5	362.5	387.5	412.5	437.5	462.5	487.5	512.5	537.5	562.5	587.5	612.5
L3	137	161	185	209	233	257	281	305	329	353	377	401	425	449	473	497	521	545	569
L4	31.5	31.5	31.5	31.5	31.5	31.5	31.5	31.5	31.5	31.5	31.5	31.5	31.5	31.5	31.5	31.5	31.5	31.5	31.5
L5	109	133	157	181	205	229	253	277	301	325	349	373	397	421	445	469	493	517	541

Dimensions: Series SV1000 for PC Wiring

● Cassette base manifold : SS5V1-16GD¹- [Stations]_B (S, R, RS) ^{C3, N1}_{C4, N3} ^{C6, N7}

- When P, E port outlets are indicated on the U side or D side, the P, E ports on the opposite side are plugged.
- External pilot port positions and silencer discharge port positions are the same as P, E port outlet positions.

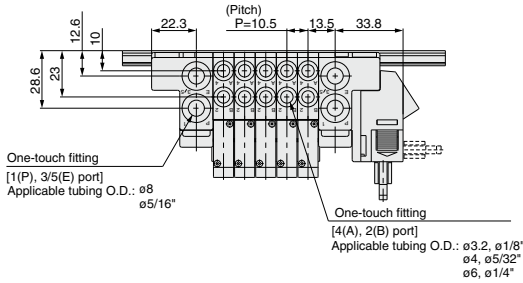

With External Pilot Specifications

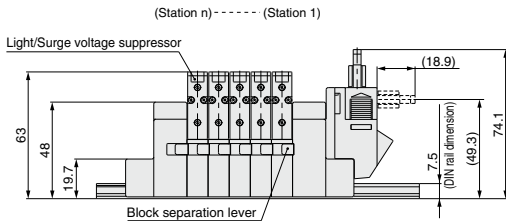
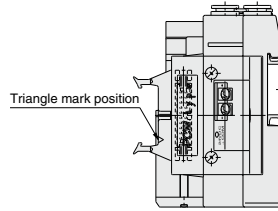
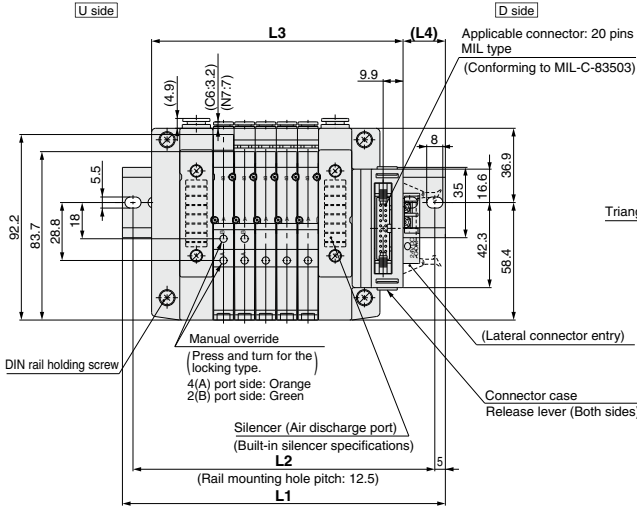
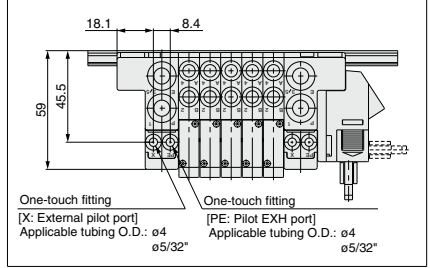

Refer to page 597 (compliant for D-sub connector) for dimensions with interface regulator and individual SUP/EXH spacer.

L Dimension

	n : Stations															
L _n	2	3	4	5	6	7	8	9	10	11	12	13	14	15	16	
L ₁	135.5	135.5	148	160.5	173	185.5	198	198	210.5	223	235.5	248	260.5	260.5	273	
L ₂	125	125	137.5	150	162.5	175	187.5	187.5	200	212.5	225	237.5	250	250	262.5	
L ₃	93.5	104	114.5	125	135.5	146	156.5	167	177.5	188	198.5	209	219.5	230	240.5	
L ₄	24.5	19	20	21	22	23	24	19	20	21	22	23	24	18.5	19.5	

- SV
- SVJ
- SZ
- VF
- VP4
- S0700
- VQ
- VQ4
- VQ5
- VQC
- VQC4
- VQZ
- SQ
- VFS
- VFR
- VQ7

Series SV

Dimensions: Series SV1000 for PC Wiring

● Tie-rod base manifold : SS5V1-10GD¹ - Stations $\frac{U}{D}$ (S, R, RS) $\frac{C3, N1}{C6, N7}$ (-D)

- When P, E port outlets are indicated on the U side or D side, the P, E ports on the opposite side are plugged.
- External pilot port positions and silencer discharge port positions are the same as P, E port outlet positions.

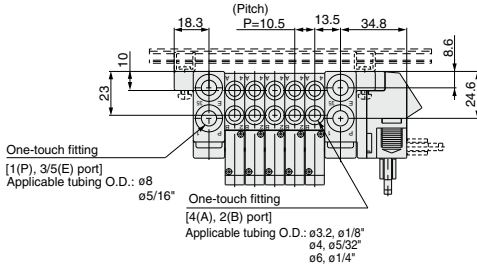

With External Pilot Specifications

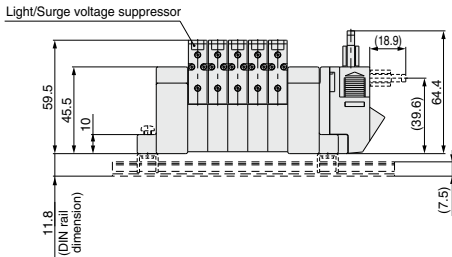
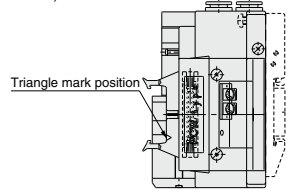
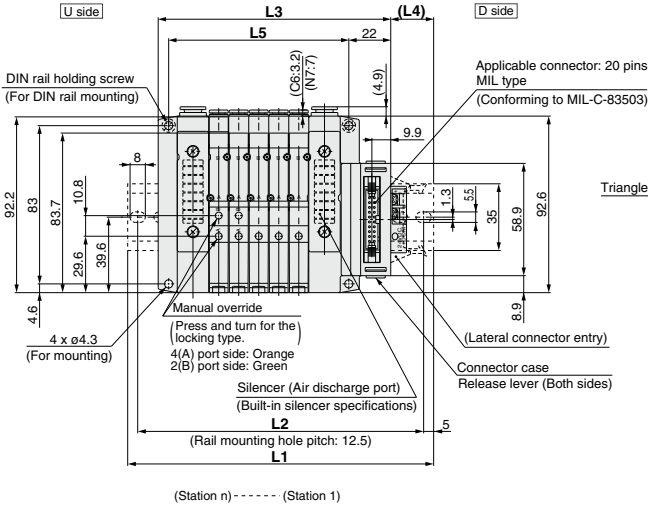
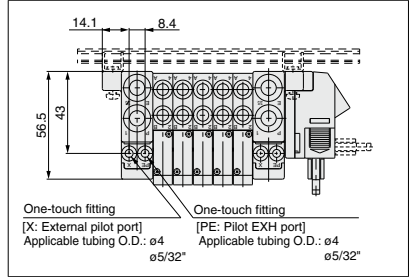

Refer to page 599 (compliant for D-sub connector) for dimensions with interface regulator and individual SUP/EXH spacer.

L Dimension

n : Stations

n	2	3	4	5	6	7	8	9	10	11	12	13	14	15	16
L1	123	135.5	148	160.5	173	173	185.5	198	210.5	223	235.5	248	248	260.5	273
L2	112.5	125	137.5	150	162.5	162.5	175	187.5	200	212.5	225	237.5	237.5	250	262.5
L3	90.5	101	111.5	122	132.5	143	153.5	164	174.5	185	195.5	206	216.5	227	237.5
L4	19.5	20.5	21.5	22.5	23.5	18.5	19.5	20.5	21.5	22.5	23.5	24.5	19	20	21
L5	63	73.5	84	94.5	105	115.5	126	136.5	147	157.5	168	178.5	189	199.5	210

Dimensions: Series SV2000 for PC Wiring

● Cassette base manifold : SS5V2-16GD₂-[Stations]_U (S, R, RS) C4, N3 C6, N7 C8, N9

- When P, E port outlets are indicated on the U side or D side, the P, E ports on the opposite side are plugged.
- External pilot port positions and silencer discharge port positions are the same as P, E port outlet positions.

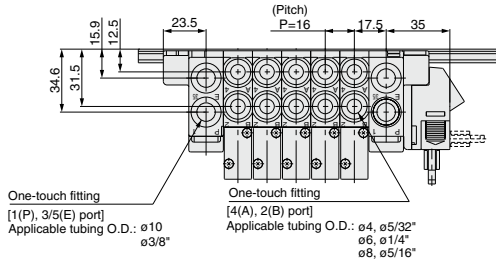

With External Pilot Specifications

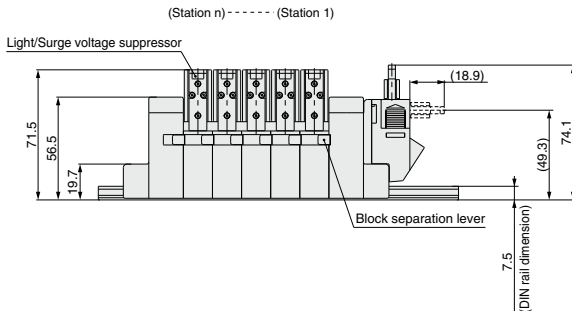
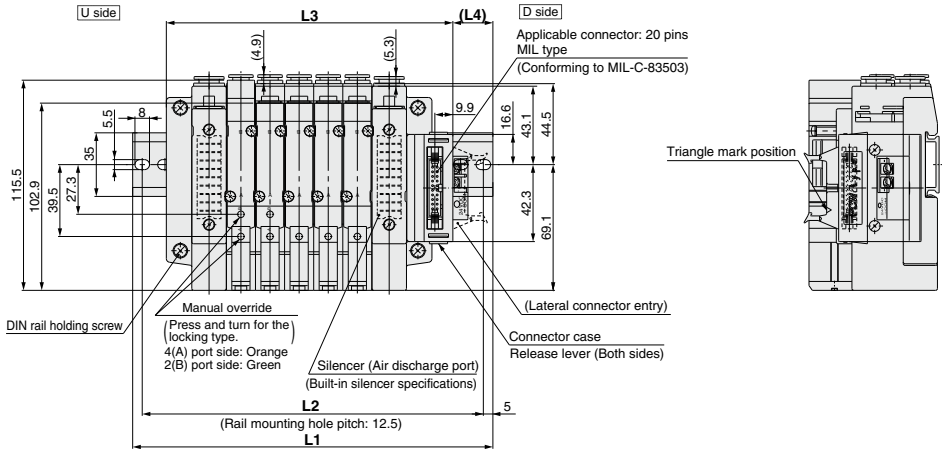
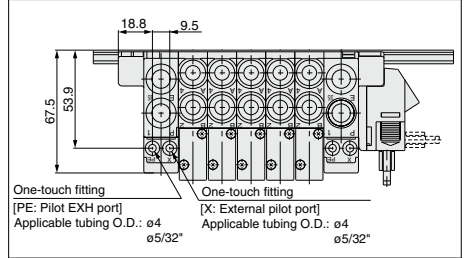

Refer to page 598 (compliant for D-sub connector) for dimensions with interface regulator and individual SUP/EXH spacer.

L Dimension

L _n	2	3	4	5	6	7	8	9	10	11	12	13	14	15	16
L1	148	160.5	173	198	210.5	223	235.5	260.5	273	285.5	310.5	323	335.5	348	373
L2	137.5	150	162.5	187.5	200	212.5	225	250	262.5	275	300	312.5	325	337.5	362.5
L3	109.5	125.5	141.5	157.5	173.5	189.5	205.5	221.5	237.5	253.5	269.5	285.5	301.5	317.5	333.5
L4	22.5	21	19	23.5	22	20	18.5	23	21	19.5	24	22	20.5	18.5	23

- SV
- SV
- SV
- SVJ
- SZ
- VF
- VP4
- S0700
- VQ
- VQ4
- VQ5
- VQC
- VQC4
- VQZ
- SQ
- VFS
- VFR
- VQ7

Series SV

Dimensions: Series SV2000 for PC Wiring

● Tie-rod base manifold : SS5V2-10GD¹ - Stations $\frac{U}{D}$ (S, R, RS) $\frac{C4, N3}{C6, N7}$ (-D)

- When P, E port outlets are indicated on the U side or D side, the P, E ports on the opposite side are plugged.
- External pilot port positions and silencer discharge port positions are the same as P, E port outlet positions.

With External Pilot Specifications

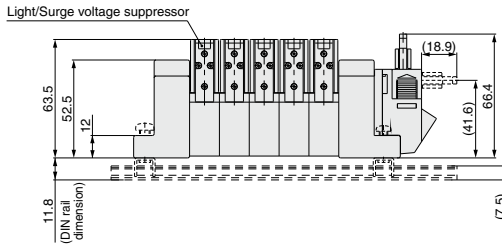
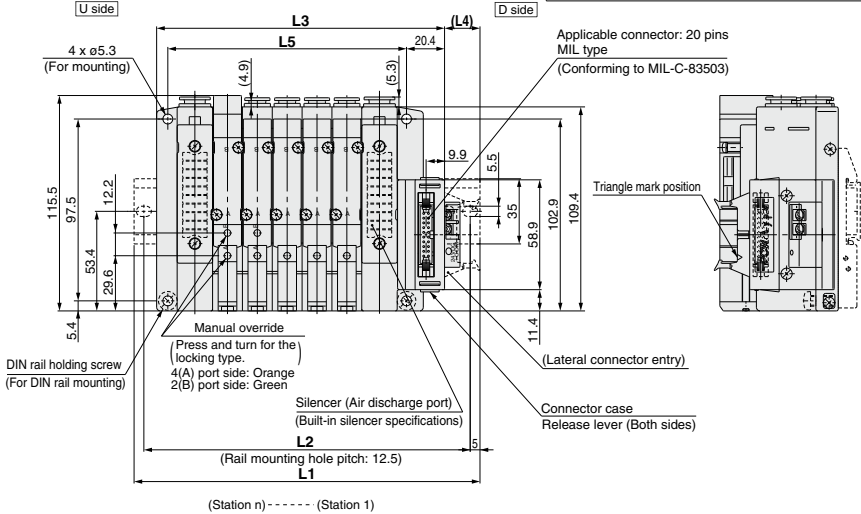
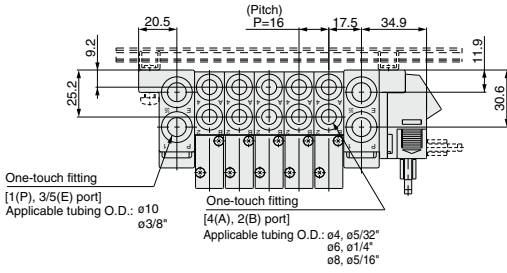
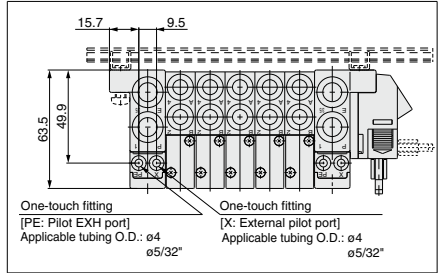

Refer to page 600 (compliant for D-sub connector) for dimensions with interface regulator and individual SUP/EXH spacer.

L Dimension

n : Stations

	2	3	4	5	6	7	8	9	10	11	12	13	14	15	16
L1	148	160.5	173	185.5	210.5	223	235.5	248	273	285.5	298	323	335.5	348	360.5
L2	137.5	150	162.5	175	200	212.5	225	237.5	262.5	275	287.5	312.5	325	337.5	350
L3	106.4	122.4	138.4	154.4	170.4	186.4	202.4	218.4	234.4	250.4	266.4	282.4	298.4	314.4	330.4
L4	24.5	22.5	20.5	19	23.5	21.5	20	18.5	22.5	21	19.5	23.5	22	20.5	18.5
L5	80	96	112	128	144	160	176	192	208	224	240	256	272	288	304

Dimensions: Series SV3000 for PC Wiring

● Tie-rod base manifold : SS5V3-10GD¹ Stations U (S, R, RS) C6, N7 C8, N9 C10, N11 (-D)

- When P, E port outlets are indicated on the U side or D side, the P, E ports on the opposite side are plugged.
- External pilot port positions and silencer discharge port positions are the same as P, E port outlet positions.

With External Pilot Specifications

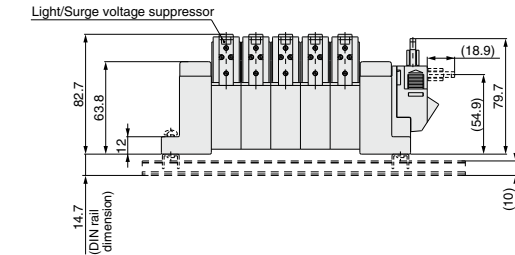
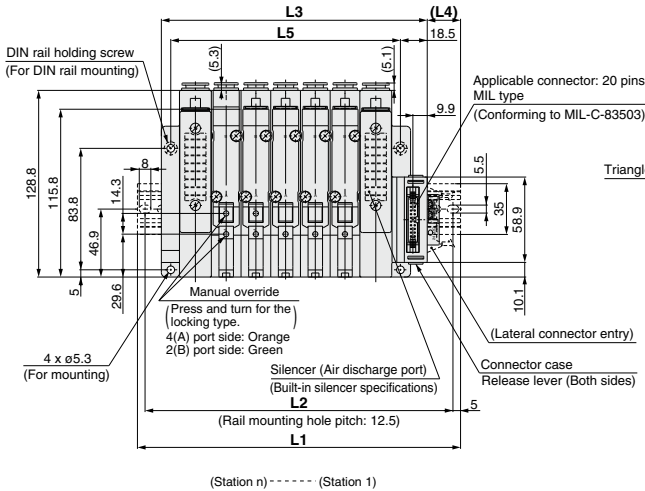
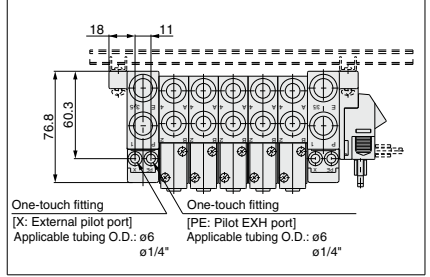
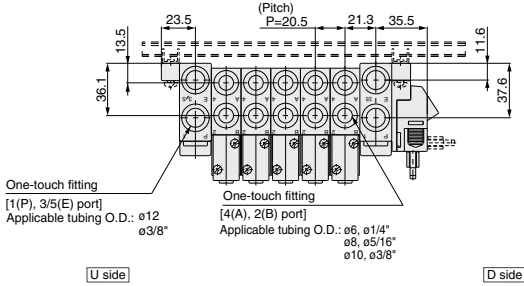

Refer to page 601 (compliant for D-sub connector) for dimensions with interface regulator and individual SUP/EXH spacer.

L Dimension

n : Stations

n	2	3	4	5	6	7	8	9	10	11	12	13	14	15	16
L1	160.5	173	198	223	235.5	260.5	285.5	298	323	348	360.5	385.5	398	423	448
L2	150	162.5	187.5	212.5	225	250	275	287.5	312.5	337.5	350	375	387.5	412.5	437.5
L3	122	142.5	163	183.5	204	224.5	245	265.5	286	306.5	327	347.5	368	388.5	409
L4	22.5	18.5	21	23	19	21.5	23.5	19.5	22	24	20	22.5	18.5	20.5	23
L5	97	117.5	138	158.5	179	199.5	220	240.5	261	281.5	302	322.5	343	363.5	384

- SJ
- SY
- SY
- SV
- SYJ
- SZ
- VF
- VP4
- S0700
- VQ
- VQ4
- VQ5
- VQC
- VQC4
- VQZ
- SQ
- VFS
- VFR
- VQ7

Series SV

Dimensions: Series SV4000 for PC Wiring

● Tie-rod base manifold : SS5V4-10GD¹ Stations $\frac{U}{D}$ (S, R, RS) $\frac{60}{60}$ CB, C10, N9, C12, N11 (-D)

- When P, E port outlets are indicated on the U side or D side, the P, E ports on the opposite side are plugged.
- External pilot port positions and silencer discharge port positions are the same as P, E port outlet positions.

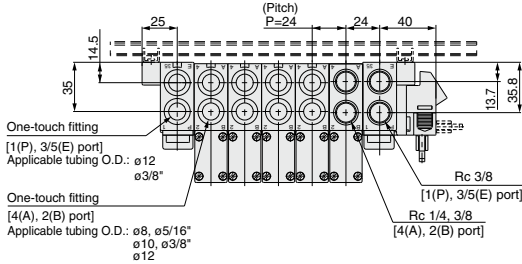

With External Pilot Specifications

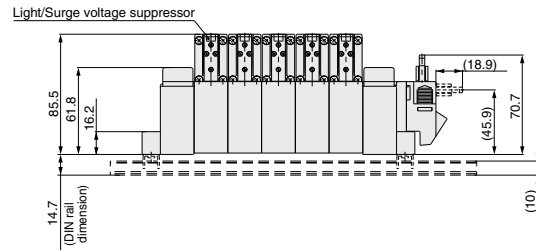
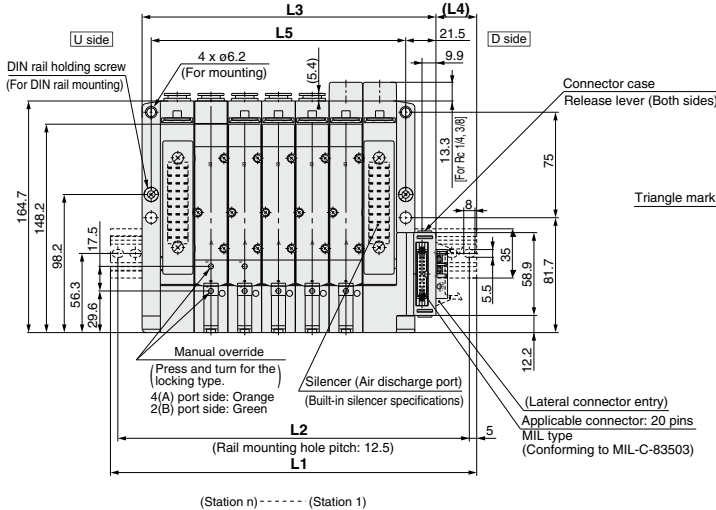
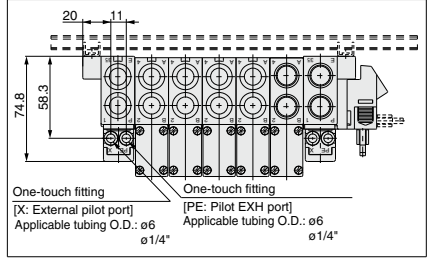

Refer to page 602 (compliant for D-sub connector) for dimensions with interface regulator and individual SUP/EXH spacer.

L Dimension

n : Stations

n	2	3	4	5	6	7	8	9	10	11	12	13	14	15	16
L1	185.5	210.5	235.5	260.5	285.5	310.5	335.5	348	373	398	423	448	473	498	523
L2	175	200	225	250	275	300	325	337.5	362.5	387.5	412.5	437.5	462.5	487.5	512.5
L3	137	161	185	209	233	257	281	305	329	353	377	401	425	449	473
L4	31.5	31.5	31.5	31.5	31.5	31.5	31.5	31.5	31.5	31.5	31.5	31.5	31.5	31.5	31.5
L5	109	133	157	181	205	229	253	277	301	325	349	373	397	421	445

Type 16: Cassette Base Manifold Exploded View

Caution

Mounting Screw Tightening Torques

M2: 0.15 N·m

M3: 0.6 N·m

M4: 1.4 N·m

Unless otherwise indicated, tighten mounting screws to the torques shown above.

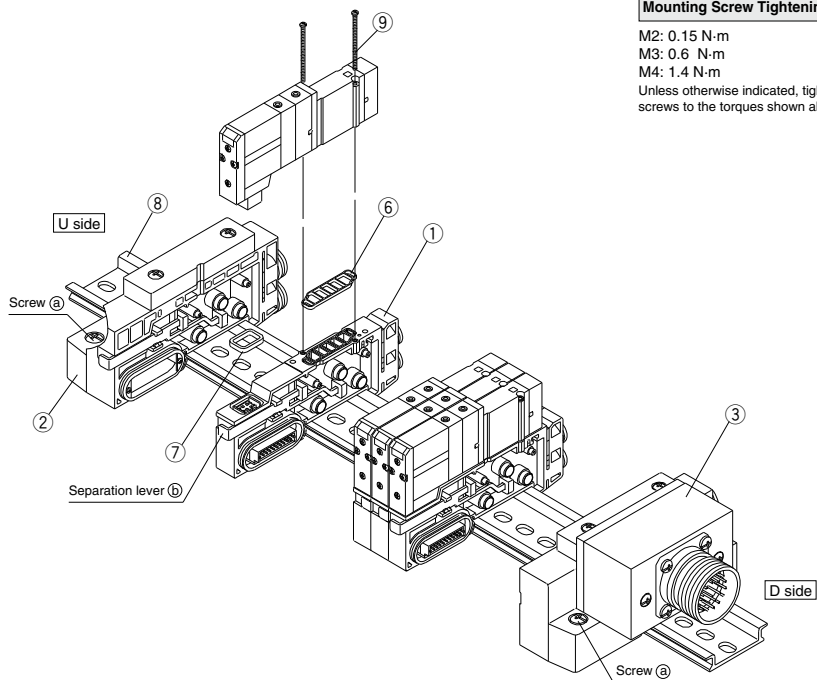

③ SUP/EXH block assembly

EX500 (Type 16SA2W)

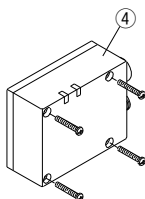
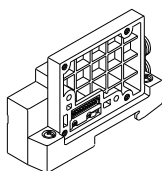

EX120 (Type 16S3□)

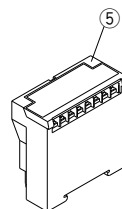
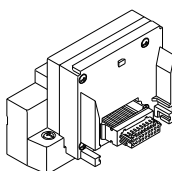

Circular connector (Type 16C)

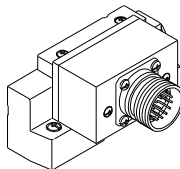

D-sub connector (Type 16F□)

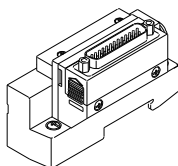

For Flat ribbon cable connector (Type 16P□)

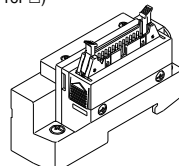

① **Manifold Block Assembly Part No.**

Series	Wiring specifications	Manifold block assembly part no.	Note
SV1000	Single	SV1000-50-3A-□□	C3: With One-touch fitting for ø3.2 N1: One-touch fitting for ø1/8" C4: With One-touch fitting for ø4 N3: One-touch fitting for ø5/32" C6: With One-touch fitting for ø6 N7: One-touch fitting for ø1/4" (Gaskets ⑥ and ⑦ are included.)
	Double	SV1000-50-4A-□□	
SV2000	Single	SV2000-50-3A-□□	C4: With One-touch fitting for ø4 N3: One-touch fitting for ø5/32" C6: With One-touch fitting for ø6 N7: One-touch fitting for ø1/4" C8: With One-touch fitting for ø8 N9: One-touch fitting for ø5/16" (Gaskets ⑥ and ⑦ are included.)
	Double	SV2000-50-4A-□□	

② SUP/EXH end block assembly SV □ 000 – 52U – 2 A □ – □

③ SUP/EXH block assembly SV □ 000 – 51D □ – □ A □ – □

Series	
1	SV1000
2	SV2000

Connector entry direction
(D-sub, flat types only)

1	Upward
2	Lateral

SUP/EXH block assembly specifications

30	For EX500 (decentralized serial)
32	For circular connector
33	D-sub connector
34	For flat ribbon cable connector (26 pins)
35	For flat ribbon cable connector (20 pins)
36	For flat ribbon cable connector (10 pins)
37	For flat ribbon cable PC wiring
38	For EX120 (dedicated output serial)

* Since EX500 and EX120 type SI units are not included, order them separately.

● P, E port size

C8	One-touch fitting for ø8	SV1000
N9	One-touch fitting for ø5/16"	
C10	One-touch fitting for ø10	SV2000
N11	One-touch fitting for ø3/8"	
00 <small>Note 1)</small>	Plug	All series
00U <small>Note 2)</small>		

Note 1) "00" (Plug) is not available for S, R and RS types.

Note 2) "00U" is available only for D-sub connectors and the lock bracket size is in inches.

● Pilot specifications

Nil	Internal pilot specifications
S	Internal pilot/Built-in silencer
R	External pilot specifications
RS	External pilot/Built-in silencer

No.	Description	Part no.		Note
		SV1000	SV2000	
④	Series EX500 SI unit	EX500-S0001		
⑤	Series EX120 SI unit	Refer to page 574.		
⑥	Gasket	SX3000-57-4	SX5000-57-6	
⑦	Connector gasket	SX3000-146-2		
⑧	DIN rail	VZ1000-11-1-□		Refer to DIN rail dimension tables on page 635.
⑨	Round head combination screw	SX3000-22-2 (M2 x 24)	SV2000-21-1 (M3 x 30)	
		Tightening torque: 0.16N·m	Tightening torque: 0.8N·m	

- SJ
- SY
- SY
- SV
- SYJ
- SZ
- VF
- VP4
- S0700
- VQ
- VQ4
- VQ5
- VQC
- VQC4
- VQZ
- SQ
- VFS
- VFR
- VQ7

Type 16: Cassette Base Manifold

How to increase manifold bases (Type 16)

- (1) Loosen the screws (a) (2 pcs. on one side) that hold the manifold base onto the DIN rail.
(When removing the manifold base from the DIN rail, loosen the holding screws at four locations.)
- (2) Using a flat head screwdriver, etc., pull the lever (b) forward on the manifold block assembly where a station is to be added, and disconnect the manifold block assemblies.
- (3) Attach the manifold block assembly to be added to the DIN rail as shown in the figure.
- (4) Connect the block assemblies by pressing them together, and push the lever (b) in firmly until it stops.
Then secure them to the DIN rail by tightening the screws (a).

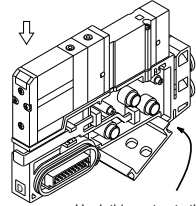

Hook this part onto the DIN rail, and press down in the direction of the arrow.

Figure. Block mounting procedure

⚠ Caution (Tightening torque: 1.4 N·m)

⚠ Caution

Fitting assembly replacement

By replacing manifold fitting assemblies, it is possible to change the size of the A, B ports and P, E ports. To replace them, Remove the clip with a flat head screwdriver, etc., and pull out the fitting assembly. Mount the new fitting assembly by inserting it and then replacing the clip to its fully inserted position.

Fitting Assembly Part No.

		Port size	SV1000	SV2000
A, B Port		One-touch fitting for ø3.2	VVQ1000-50A-C3	—
		One-touch fitting for ø4	VVQ1000-50A-C4	VVQ1000-51A-C4
		One-touch fitting for ø6	VVQ1000-50A-C6	VVQ1000-51A-C6
		One-touch fitting for ø8	—	VVQ1000-51A-C8
		One-touch fitting for ø1/8"	VVQ1000-50A-N1	—
		One-touch fitting for ø5/32"	VVQ1000-50A-N3	VVQ1000-51A-N3
		One-touch fitting for ø1/4"	VVQ1000-50A-N7	VVQ1000-51A-N7
P, E Port		One-touch fitting to ø5/16"	—	VVQ1000-51A-N9
		One-touch fitting for ø8	VVQ1000-51A-C8	—
		One-touch fitting for ø10	—	VVQ2000-51A-C10
		One-touch fitting for ø5/16"	VVQ1000-51A-N9	—
		One-touch fitting for ø3/8"	—	VVQ2000-51A-N11

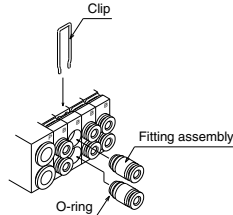

Note 1) Be careful to avoid damage or contamination of O-rings, as this can cause air leakage.

Note 2) When removing a fitting assembly from a valve, after removing the clip, attach tubing or a plug (KQ2P-□□) to the One-touch fitting, and pull it out while holding the tubing (or plug). If it is pulled out while holding the release button of the fitting assembly (resin part), the release button may be damaged.

Note 3) Be sure to shut off the power and air supplies before disassembly. Furthermore, since air may remain inside the actuator, piping and manifold, confirm that the air is completely exhausted before performing any work.

■ How to order cassette base type 16 solenoid valves with manifold block

[Series SV1000/SV2000]

• Type with manifold block is used when adding stations, etc.

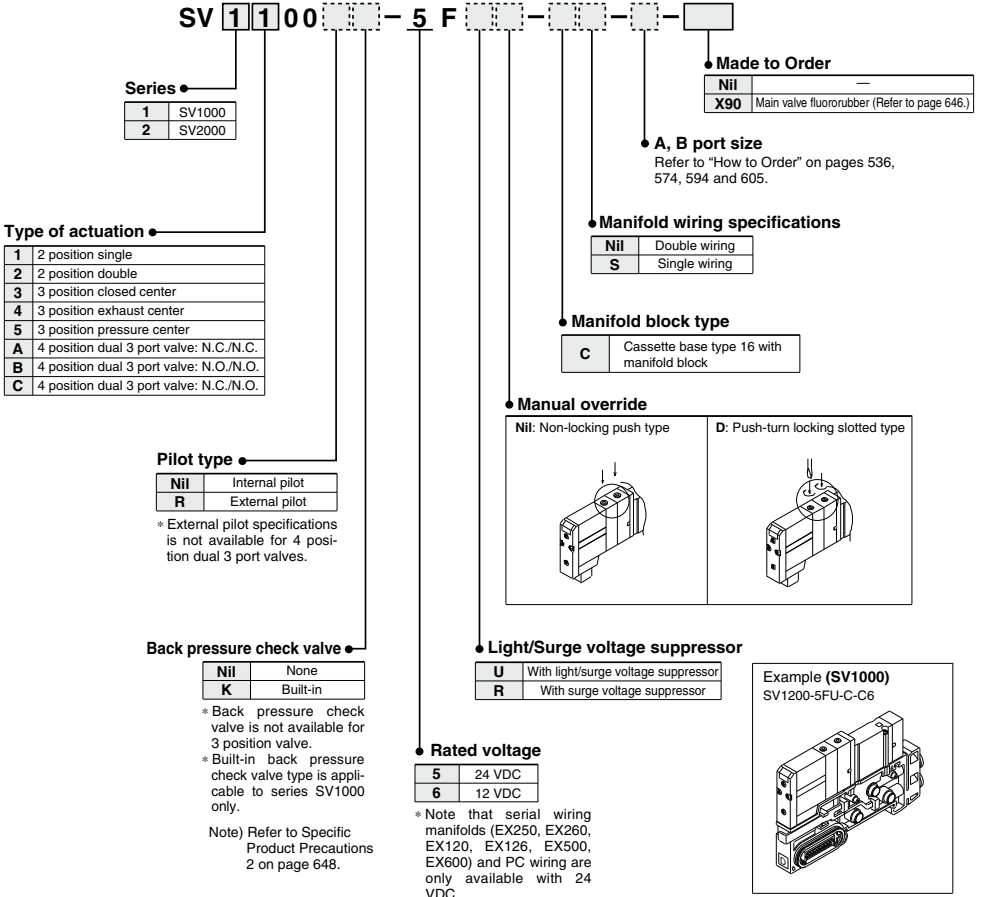

- SJ
- SY
- SY
- SV
- SYJ
- SZ
- VF
- VP4
- S0700
- VQ
- VQ4
- VQ5
- VQC
- VQC4
- VQZ
- SQ
- VFS
- VFR
- VQ7

Type 10: Tie-rod Base Manifold Exploded View

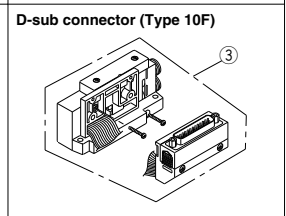
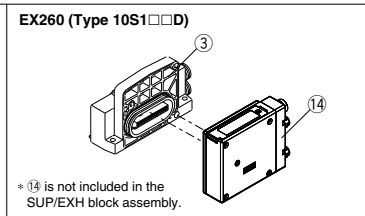
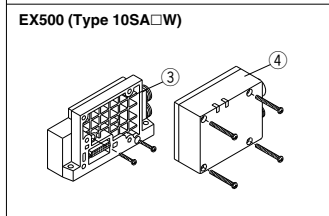
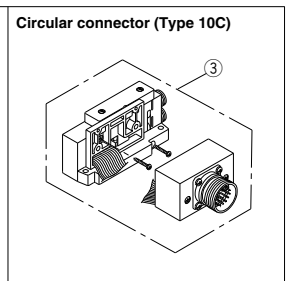
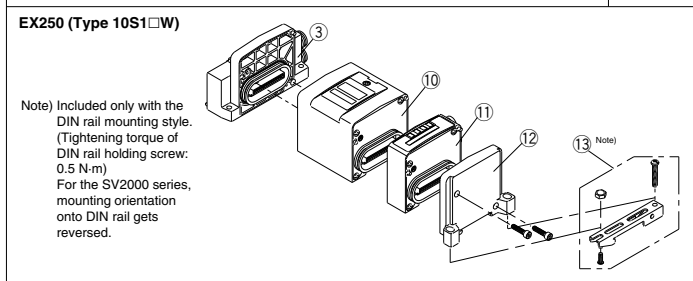
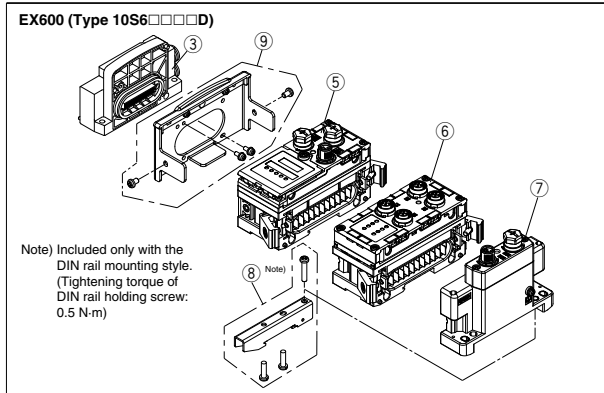
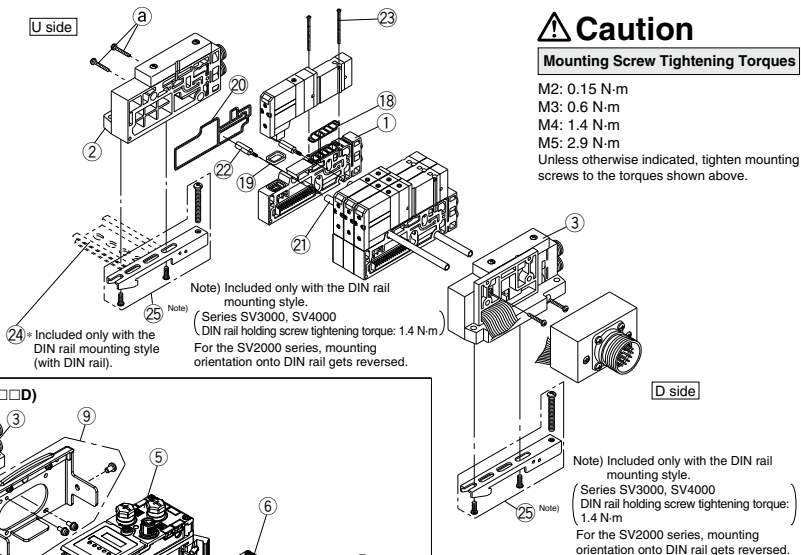

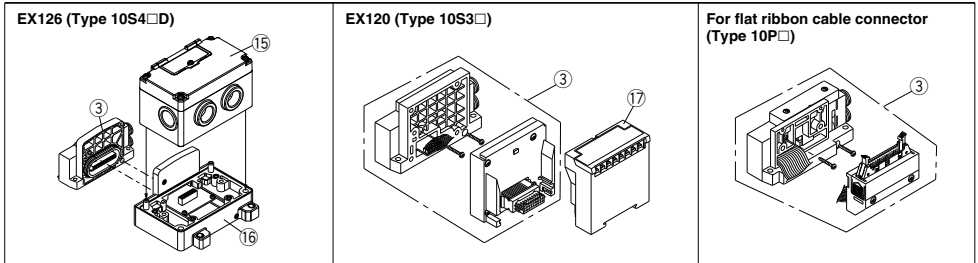

① Manifold Block Assembly Part No.

Series	Wiring specifications	Manifold block assembly part no.	Note
SV1000	Single	SV1000-50-1A-□□	C3: With ø3.2 One-touch fitting N1: ø1/8" One-touch fitting
	Double	SV1000-50-2A-□□	C4: With ø4 One-touch fitting N3: ø5/32" One-touch fitting C6: With ø6 One-touch fitting N7: ø1/4" One-touch fitting (Tie-rod for station additions ② and gaskets ⑬, ⑭, and ⑯ are included.)
SV2000	Single	SV2000-50-1A-□□	C4: With ø4 One-touch fitting N3: ø5/32" One-touch fitting
	Double	SV2000-50-2A-□□	C6: With ø6 One-touch fitting N7: ø1/4" One-touch fitting C8: With ø8 One-touch fitting N9: ø5/16" One-touch fitting (Tie-rod for station additions ② and gaskets ⑬, ⑭, and ⑯ are included.)
SV3000	Single	SV3000-50-1A-□□	C6: With ø6 One-touch fitting N7: ø1/4" One-touch fitting
	Double	SV3000-50-2A-□□	C8: With ø8 One-touch fitting N9: ø5/16" One-touch fitting C10: With ø10 One-touch fitting N11: ø3/8" One-touch fitting (Tie-rod for station additions ② and gaskets ⑬, ⑭, and ⑯ are included.)
SV4000	Single	SV4000-50-1A-□□	C8: With ø8 One-touch fitting N9: ø5/16" One-touch fitting
	Double	SV4000-50-2A-□□	C10: With ø10 One-touch fitting N11: ø3/8" One-touch fitting C12: With ø12 One-touch fitting 02: Rc 1/4 02N: NPT 1/4 03: Rc 3/8 03N: NPT 3/8 02F: G1/4 02T: NPTF 1/4 03F: G3/8 03T: NPTF 3/8 (Tie-rod for station additions ② and gaskets ⑬, ⑭, and ⑯ are included.)

② SUP/EXH end block assembly SV □000-52U - 1 A □-□-□

③ SUP/EXH block assembly SV □000-51D □-□ A □-□-□

Series

1	SV1000
2	SV2000
3	SV3000
4	SV4000

Connector entry direction
(D-sub, flat types only)

1	Upward
2	Lateral

Mounting

Nil	Direct mounting
DO	DIN rail mounting

SUP/EXH block assembly specifications

10	For EX500 (decentralized serial)
11	For EX600 (serial wiring with I/O unit)
	For EX250 (serial wiring with I/O unit)
	For EX260 (dedicated output serial)
12	For EX126 (dedicated output serial)
	For EX126 (dedicated output serial)
12	For circular connector
13	D-sub connector
14	For flat ribbon cable connector (26 pins)
15	For flat ribbon cable connector (20 pins)
16	For flat ribbon cable connector (10 pins)
17	For flat ribbon cable PC wiring
18	For EX120 (dedicated output serial)

Pilot type

Nil	Internal pilot
S	Internal pilot/Built-in silencer
R	External pilot
RS	External pilot/Built-in silencer

P, E port size

C8	ø8 One-touch fitting	SV1000	
N9	ø5/16" One-touch fitting		
C10	ø10 One-touch fitting	SV2000	
N11	ø3/8" One-touch fitting		
C12	ø12 One-touch fitting	SV3000	
N11	ø3/8" One-touch fitting	SV4000	
03	Rc 3/8		
03F	G 3/8		
03N	NPT 3/8	SV4000	
03T	NPTF 3/8		
00	Note 1)		
00U	Note 2)	Plug	All series

Note 1) "00" (Plug) is not available for S, R and RS types.
Note 2) "00U" is available only for D-sub connectors and the lock bracket size is in inches.

SV
SY
SV
SYJ
SZ
VF
VP4
S0700
VQ
VQ4
VQ5
VQC
VQC4
VQZ
SQ
VFS
VFR
VQ7

* Since EX500, EX600, EX250, EX260, EX126 and EX120 type SI units are not included, order them separately.

Type 10: Tie-rod Base Manifold Exploded View

No.	Description	Part no.				Note	
		SV1000	SV2000	SV3000	SV4000		
4	Series EX500 SI unit	Refer to page 536.			—		
5	Series EX600 SI unit	EX600-SDN1A	—	—	—	DeviceNet™ PNP (Negative common)	
		EX600-SDN2A	—	—	—	DeviceNet™ NPN (Positive common)	
		EX600-SMJ1	—	—	—	CC-Link PNP (Negative common)	
		EX600-SMJ2	—	—	—	CC-Link NPN (Positive common)	
		EX600-SPR1A	—	—	—	PROFIBUS DP PNP (Negative common)	
		EX600-SPR2A	—	—	—	PROFIBUS DP NPN (Positive common)	
		EX600-SEN1	—	—	—	EtherNet/IP™ PNP (Negative common)	
		EX600-SEN2	—	—	—	EtherNet/IP™ NPN (Positive common)	
		EX600-DXNB	—	—	—	NPN input M12 connector 5 pins (4 pcs.) 8 inputs	
		EX600-DXPB	—	—	—	NPN input M12 connector 5 pins (4 pcs.) 8 inputs	
6	Series EX600 digital input unit	EX600-DXNC	—	—	—	NPN input M8 connector 3 pins (8 pcs.) 8 inputs	
		EX600-DXNC1	—	—	—	NPN input M8 connector 3 pins (8 pcs.) 8 inputs, with open circuit detection	
		EX600-DXPC	—	—	—	PNP input M8 connector 3 pins (8 pcs.) 8 inputs	
		EX600-DXPC1	—	—	—	PNP input M8 connector 3 pins (8 pcs.) 8 inputs, with open circuit detection	
		EX600-DXND	—	—	—	NPN input M12 connector 5 pins (8 pcs.) 16 inputs	
		EX600-DXPD	—	—	—	PNP input M12 connector 5 pins (8 pcs.) 16 inputs	
		EX600-DXNE	—	—	—	NPN input D-sub connector 25 pins 16 inputs	
		EX600-DXPE	—	—	—	PNP input D-sub connector 25 pins 16 inputs	
		EX600-DXNF	—	—	—	NPN input spring type terminal block 32 pins 16 inputs	
		EX600-DXPF	—	—	—	PNP input spring type terminal block 32 pins 16 inputs	
	Series EX600 digital output unit	EX600-DYNB	—	—	—	NPN output M12 connector 5 pins (4 pcs.) 8 outputs	
		EX600-DYPB	—	—	—	PNP output M12 connector 5 pins (4 pcs.) 8 outputs	
		EX600-DYNE	—	—	—	NPN output D-sub connector 25 pins 16 outputs	
		EX600-DYPE	—	—	—	PNP output D-sub connector 25 pins 16 outputs	
		EX600-DYNF	—	—	—	NPN output spring type terminal block 32 pins 16 outputs	
		EX600-DYPE	—	—	—	PNP output spring type terminal block 32 pins 16 outputs	
		Series EX600 digital input/output unit	EX600-DMNE	—	—	—	NPN input/output D-sub connector 25 pins 8 inputs/outputs
			EX600-DMPE	—	—	—	PNP input/output D-sub connector 25 pins 8 inputs/outputs
EX600-DMNF	—		—	—	NPN input/output spring type terminal block 32 pins 8 inputs/outputs		
EX600-DMPF	—		—	—	PNP input/output spring type terminal block 32 pins 8 inputs/outputs		
Series EX600 analog input unit	EX600-AXA	—	—	—	M12 connector 5 pins (2 pcs.), 2-channel input		
Series EX600 analog output unit	EX600-AYA	—	—	—	M12 connector 5 pins (2 pcs.), 2-channel output		
Series EX600 analog input/output unit	EX600-AMB	—	—	—	M12 connector 5 pins (4 pcs.), 2-channel input/output		
7	End plate for Series EX600	EX600-ED2	—	—	—	M12 connector 5 pins, max. supply current 2A	
		EX600-ED2-2	—	—	—	M12 connector 5 pins, max. supply current 2A, with DIN rail mounting bracket	
		EX600-ED3	—	—	—	7/8 inch connector 5 pins, max. supply current 8A	
		EX600-ED3-2	—	—	—	7/8 inch connector 5 pins, max. supply current 8A, with DIN rail mounting bracket	
		EX600-ED2	—	—	—	M12 connector 5 pins, max. supply current 2A	
8	Clamp assembly for EX600	EX600-ZMA2	—	—	With mounting screws (M4 x 20 1 pc., M4 x 12 2 pcs.)		
9	Valve plate for EX600	EX600-ZMV1	—	—	Enclosed parts: round head screws (M4 x 6) 2 pcs., round head screws (M3 x 8) 4 pcs.		
10	Series EX250 SI unit	Refer to page 546.			—	M12, 2 inputs	
11	Series EX250 input block	EX250-IE1	—	—	—	M12, 4 inputs	
		EX250-IE2	—	—	—	M8, 4 inputs (3 pins)	
		EX250-IE3	—	—	—	With mounting screws (M3 x 10, 2 pcs.)	
		EX250-EA1	—	—	—		
12	Series EX250 end plate assembly	EX250-EA1	—	—			
13	For EX250 clamp assembly	SV1000-78A	—	—			
14	Series EX260 SI unit	Refer to page 562.			—		
15	Series EX126 SI unit	Refer to page 568.			—		
16	Terminal block plate	VVQC1000-74A-2	—	—	—	For mounting EX126 SI unit	
17	Series EX120 SI unit	Refer to page 574.			—		
18	Gasket	SX3000-57-4	SX5000-57-6	SX7000-57-5	SY9000-11-2		
19	Connector gasket	SX3000-146-2	SX3000-146-2	SX3000-146-2	SX3000-146-2		
20	Manifold block gasket	SX3000-181-1	SX5000-138-1	SV3000-65-1	SV4000-65-2		
21	Tie-rod	SV1000-55-1-□□	SV2000-55-1-□□	SV3000-55-1-□□	SV4000-55-1-□□	□□: Manifold stations	
22	Tie-rod for station addition	SV1000-55-2-1	SV2000-55-2A	SV3000-55-2A	SV4000-55-2A		
23	Round head combination screw (Valve mounting screw)	SX3000-22-2 (M2 x 24)	SV2000-21-1 (M3 x 30)	SV3000-21-1 (M4 x 35)	SV2000-21-2 (M3 x 40)		
		Tightening torque: 0.16 N·m	Tightening torque: 0.8 N·m	Tightening torque: 1.4 N·m	Tightening torque: 0.8 N·m		
24	DIN rail	VZ1000-11-1-□	VZ1000-11-1-□	VZ1000-11-4-□	VZ1000-11-4-□	Refer to DIN rail dimension tables on page 635.	
25	Clamp assembly	SV1000-69A	—	—	—		
		SV1000-69A	SV2000-75A	SV3000-69A	SV3000-69A		
	Clamp assembly for EX600	SV1000-69A	SV2000-75A	SV3000-69A	—		

Note) Two pieces of ① and ② (tie-rod) are required for Series SV1000, and three pieces are required for Series SV2000, 3000 and 4000.
Two pieces of ③ (valve mounting screw) are required for Series SV1000, 2000 and 3000, and three pieces are required for Series SV4000.

Type 10: Tie-rod Base Manifold

How to increase manifold bases (Type 10)

- (1) Loosen the U side screws (a), and remove the SUP/EXH end block assembly (2).



- (2) Screw in the tie-rods (14) for station addition.
(Screw them in until there is no gap between the tie-rods.)



- (3) Connect the manifold assembly (1) and supply/exhaust end block assembly (2) to be added, and tighten the screws (a).

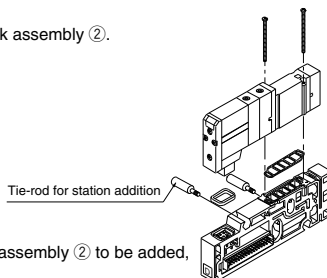

⚠ Caution Tightening torques (a)

SV1000, SV2000	0.6 N·m
SV3000	1.4 N·m
SV4000	2.9 N·m

Note) When eliminating manifold stations, the appropriate tie-rods (13) for the desired change should be ordered separately.
(When equipped with a DIN rail, be sure to tighten the DIN rail holding screws after tightening the tension bolts.)

⚠ Caution

Fitting Assembly Replacement

By replacing manifold fitting assemblies, it is possible to change the size of the A, B ports and P, E ports. To replace them, remove the clip with a flat head screwdriver, etc., and pull out the fitting assembly. Mount the new fitting assembly by inserting it and then replacing the clip to its fully inserted position.

Fitting Assembly Part No.

Port size		SV1000	SV2000	SV3000	SV4000
A, B Port	One-touch fitting for ø3.2	VVQ1000-50A-C3	—	—	—
	One-touch fitting for ø4	VVQ1000-50A-C4	VVQ1000-51A-C4	—	—
	One-touch fitting for ø6	VVQ1000-50A-C6	VVQ1000-51A-C6	VVQ2000-51A-C6	—
	One-touch fitting for ø8	—	VVQ1000-51A-C8	VVQ2000-51A-C8	VVQ4000-50B-C8
	One-touch fitting for ø10	—	—	VVQ2000-51A-C10	VVQ4000-50B-C10
	One-touch fitting for ø12	—	—	—	VVQ4000-50B-C12
	One-touch fitting for ø1/8"	VVQ1000-50A-N1	—	—	—
	One-touch fitting for ø5/32"	VVQ1000-50A-N3	VVQ1000-51A-N3	—	—
	One-touch fitting for ø1/4"	VVQ1000-50A-N7	VVQ1000-51A-N7	VVQ2000-51A-N7	—
	One-touch fitting for ø5/16"	—	VVQ1000-51A-N9	VVQ2000-51A-N9	VVQ4000-50B-N9
One-touch fitting for ø3/8"	—	—	VVQ2000-51A-N11	VVQ4000-50B-N11	
1/4 threaded type port block assembly	—	—	—	SY9000-58A-02□	
3/8 threaded type port block assembly	—	—	—	SY9000-58A-03□	
P, E Port	One-touch fitting for ø8	VVQ1000-51A-C8	—	—	—
	One-touch fitting for ø10	—	VVQ2000-51A-C10	—	—
	One-touch fitting for ø12	—	—	VVQ4000-50B-C12	VVQ4000-50B-C12
	One-touch fitting for ø5/16"	VVQ1000-51A-N9	—	—	—
	One-touch fitting for ø3/8"	—	VVQ2000-51A-N11	VVQ4000-50B-N11	VVQ4000-50B-N11
3/8 threaded type port block assembly	—	—	—	SY9000-58B-03□	

■ 1/4, 3/8 thread type port block assembly

For A, B port

SY9000-58A-02 

For P, E port

SY9000-58B-03 

● Thread type

Nil	Rc
F	G
N	NPT
T	NPTF

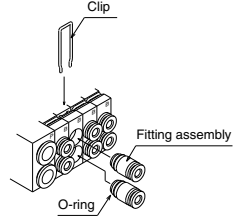

- Note 1) Be careful to avoid damage or contamination of O-rings, as this can cause air leakage.
 Note 2) When removing a fitting assembly from a valve, after removing the clip, attach tubing or a plug (KQP-□□) to the One-touch fitting, and pull it out while holding the tubing (or plug). If it is pulled out while holding the release button of the fitting assembly (resin part), the release button may be damaged. However, 02 and 03 port block assemblies should be pulled out as they are.
 Note 3) Be sure to shut off the power and air supplies before disassembly. Furthermore, since air may remain inside the actuator, piping and manifold, confirm that the air is completely exhausted before performing any work.

■ How to order tie-rod type 10 solenoid valves with manifold block

[Series SV1000 to SV4000]

- Type with manifold block is used when adding stations, etc.

SV 1 1 00 - 5 F

1	SV1000
2	SV2000
3	SV3000
4	SV4000

● Type of actuation

1	2 position single
2	2 position double
3	3 position closed center
4	3 position exhaust center
5	3 position pressure center
A	4 position dual 3 port valve: N.C./N.C.
B	4 position dual 3 port valve: N.O./N.O.
C	4 position dual 3 port valve: N.C./N.O.

* 4 position dual 3 port valves are applicable to Series SV1000 and SV2000 only.

● Pilot type

Nil	Internal pilot
R	External pilot

* External pilot specifications is not available for 4 position dual 3 port valves.

● Back pressure check valve

Nil	None
K	Built-in

- * Built-in back pressure check valve type is applicable to series SV1000 only.
- * Back pressure check valve is not available for 3 position valve.

(Note) Refer to Specific Product Precautions 2 on page 648.

● A, B port size

Refer to "How to Order" on pages 536, 546, 568, 574, 584, 594 and 605

● Manifold wiring specifications

Nil	Double wiring
S	Single wiring

● Made to Order

Nil	—
X90	Main valve fluororubber (Refer to page 646.)

● Manifold block type

T	For Tie-rod base type 10 with manifold block
---	----------------------------------------------

Note) Tie-rod type 10 includes tie-rods for station additions.

● Manual override

Nil: Non-locking push type

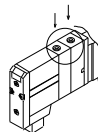

D: Push-turn locking slotted type

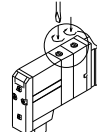

● Light/Surge voltage suppressor

U	With light/surge voltage suppressor
R	With surge voltage suppressor

● Rated voltage

5	24 VDC
6	12 VDC

* Note that serial wiring (EX500, EX250 and EX12□) are only available with 24 VDC.

Example (SV1000)
SV1200-5FU-T-C6

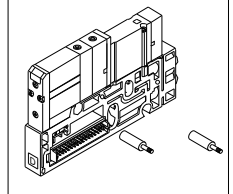

SV
SV
SV
SV
SVJ
SZ
VF
VP4
S0700
VQ
VQ4
VQ5
VQC
VQC4
VQZ
SQ
VFS
VFR
VQ7

Series SV

Manifold Options (Common for Type 16 and 10)

Relay output module

By adding a relay output module to a series SV manifold, devices up to 110 VAC, 3 A (large type solenoid valves, etc.) can be controlled together with Series SV valves.

How to Order

SV 000-60-5 A-1A

Series ●

1	SV1000
2	SV2000
3	SV3000
4	SV4000

● No. of output point

A	1 output
B	2 outputs

● Rated voltage

5	24 VDC
6	12 VDC

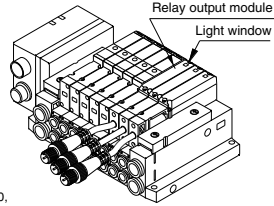

* Note that serial wiring manifolds (EX500, EX250 and EX12□) are available with 24 VDC only.

Relay Output Module Specifications

Item	Specifications			
No. of output points	1 output [connector with lead wire (M12)]		2 outputs [connector with lead wire (M12)]	
Output type	<p>Contact type ("a" contact)</p>		<p>Contact type ("a" contact)</p>	
Load voltage	110 VAC	30 VDC	110 VAC	30 VDC
Load current	3 A	3 A	0.3 A	1 A
Indicator light	Orange		A side: Orange B side: Green	
Enclosure	Based on IP67 (IEC60529)			
Current consumption	20 mA or less			
Polarity	Non-polar			
weight (g)	48			

Connection Destination (Female Side) Connector Cable

Connector size	pin	Manufacturer	Applicable series
M12	4	Correns Corp.	VA-4D
		OMRON Corp.	XS2
		Azbil Corp.	PA5-41
		Hirose Electric Co., Ltd.	HR24
		DDK Ltd.	CM01-8DP4S

* This connector is a female connector for ① relay output module and ② single unit/sub-plate.

Y type connector

Used to branch a two output relay output module to two separate systems.

How to Order

EX500-ACY00-S



Relay output module and Y type connector wiring example

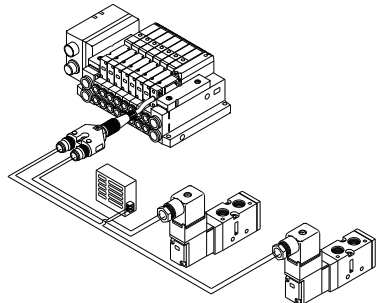
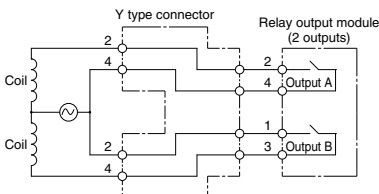

Manifold Options

■ Blanking plate assembly

Used in situations where valves will be added in the future or for maintenance.

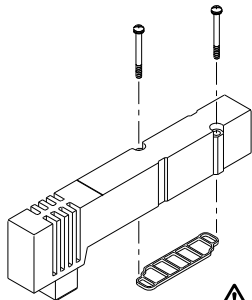

Series	Blanking plate assembly part no.
SV1000	SV1000-67-1A
SV2000	SV2000-67-1A
SV3000	SV3000-67-1A
SV4000	SV4000-67-1A

⚠ Caution

Mounting screw
tightening torques

M2: 0.16 N·m

M3: 0.8 N·m

M4: 1.4 N·m

■ SUP/EXH block disk

[SUP block disk]

By placing a SUP block disk in a manifold valve's pressure supply passage, two different high and low pressures can be supplied to one manifold.

[EXH block disk]

By installing an EXH block disk in a manifold valve's exhaust passage, the valve's exhaust can be separated so that it will not affect other valves. It can also be used on a manifold with mixed positive pressure and vacuum.

(Two pieces are required to block EXH on both sides. However, Series SV1000 and 2000 type 10 manifolds require only one piece.)

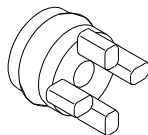

Cassette base type 16

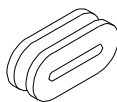

Tie-rod base type 10

Series	Manifold Model	SUP block disk	EXH block disk
SV1000	10	SV1000-59-1A	SV1000-59-2A
	16	SX3000-77-1A	SX3000-77-1A
SV2000	10	SV2000-59-1A	SV2000-59-2A
	16	SV2000-59-3A	SV2000-59-3A
SV3000	10	SV3000-59-1A	SV3000-59-1A
SV4000	10	SY9000-57-1A	SY9000-57-1A

■ Label for block disk

These labels are attached to manifolds in which SUP and EXH block disks have been installed, in order to identify the installed locations. (Three sheets each included.)

SV1000-74-1A

Label for SUP
block disk



Label for EXH
block disk



Label for SUP/EXH
block disk



* When a block disk is concurrently ordered by specifying on the manifold specification sheet, etc., a label will be stuck on the position where block disk is mounted.

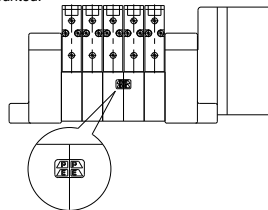

■ Silencer (Compact resin type/One-touch fitting connection)

AN10-C to AN30-C

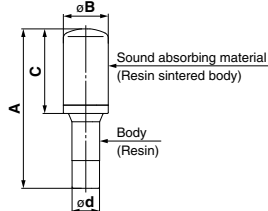

Dimensions

Series	Model	A	B	C	ϕd
SV1000 (For $\phi 8$)	AN15-C08	45	13	20	$\phi 8$
SV2000 (For $\phi 10$)	AN20-C10	57.5	16.5	30.5	$\phi 10$
SV3000, SV4000 (For $\phi 12$)	AN30-C12	71.5	20	43.5	$\phi 12$

■ Plug (White)

These are inserted in unused cylinder ports and P, E ports.

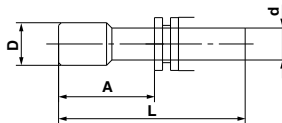

Applicable fitting size d	Model	A	L	D
$\phi 4$	KQ2P-04	16	32	$\phi 6$
$\phi 6$	KQ2P-06	18	35	$\phi 8$
$\phi 8$	KQ2P-08	20.5	39	$\phi 10$
$\phi 10$	KQ2P-10	22	43	$\phi 12$
$\phi 12$	KQ2P-12	24	44.5	$\phi 14$
$\phi 1/8"$	KQ2P-01	16	31.5	$\phi 5$
$\phi 5/32"$	KQ2P-03	16	32	$\phi 6$
$\phi 1/4"$	KQ2P-07	18	35	$\phi 8.5$
$\phi 5/16"$	KQ2P-09	20.5	39	$\phi 10$
$\phi 3/8"$	KQ2P-11	22	43	$\phi 11.5$

Manifold Options

■ Circular connector/Cable assembly (26 pins)

AXT100 – MC26 – □

Lead Wire Length

Part no.	L dimension
AXT100-MC26-015	1.5 m
AXT100-MC26-030	3 m
AXT100-MC26-050	5 m

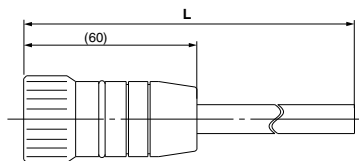

Plug terminal no.
(arrangement as seen from lead wire side)

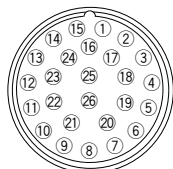

Circular Connector Cable Assembly Terminal No.

Terminal no.	Lead wire color	Dot marking
①	Black	None
②	Brown	None
③	Red	None
④	Orange	None
⑤	Yellow	None
⑥	Pink	None
⑦	Blue	None
⑧	Purple	White
⑨	Gray	Black
⑩	White	Black
⑪	White	Red
⑫	Yellow	Red
⑬	Orange	Red
⑭	Yellow	Black
⑮	Pink	Black
⑯	Blue	White
⑰	Purple	None
⑱	Gray	None
⑲	Orange	Black
⑳	Red	White
㉑	Brown	White
㉒	Pink	Red
㉓	Gray	Red
㉔	Black	White
㉕	White	None

Note) Terminal no. ㉕ is connected to ㉔ inside the connector.

■ D-sub connector/Cable assembly (25 pins)

AXT100 – DS25 – □

Lead Wire Length

Part no.	L dimension
AXT100-DS25-015	1.5 m
AXT100-DS25-030	3 m
AXT100-DS25-050	5 m

When a commercially available connector is required, use a 25 pin female connector conforming to MIL-C24308.

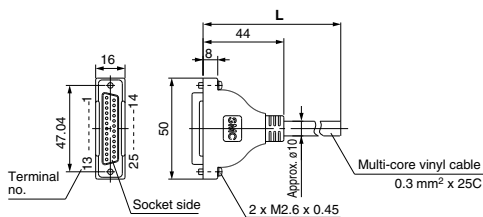

D-sub Connector Cable Assembly Terminal No.

Terminal no.	Lead wire color	Dot marking
①	Black	None
②	Brown	None
③	Red	None
④	Orange	None
⑤	Yellow	None
⑥	Pink	None
⑦	Blue	None
⑧	Purple	White
⑨	Gray	Black
⑩	White	Black
⑪	White	Red
⑫	Yellow	Red
⑬	Orange	Red
⑭	Yellow	Black
⑮	Pink	Black
⑯	Blue	White
⑰	Purple	None
⑱	Gray	None
⑲	Orange	Black
⑳	Red	White
㉑	Brown	White
㉒	Pink	Red
㉓	Gray	Red
㉔	Black	White
㉕	White	None

Circular Connector, D-sub Connector Cable Assembly Electric Characteristics

Item	Characteristics
Conductor resistance Ω/km, 20°C	65 or less
Withstand voltage VAC, 1 min.	1000
Insulation resistance, MΩkm, 20°C	5 or less

Note) The minimum inside bending radius for each cable is 20 mm.

Manifold Options

■ Flat ribbon cable/Cable assembly

AXT100 – FC □ – □

Cable length (L)	10 pins	20 pins	26 pins
1.5 m	AXT100-FC10-1	AXT100-FC20-1	AXT100-FC26-1
3 m	AXT100-FC10-2	AXT100-FC20-2	AXT100-FC26-2
5 m	AXT100-FC10-3	AXT100-FC20-3	AXT100-FC26-3
Connector width (W)	17.2	30	37.5

* For other commercial connectors, use a type with strain relief conforming to MIL-C-83503.

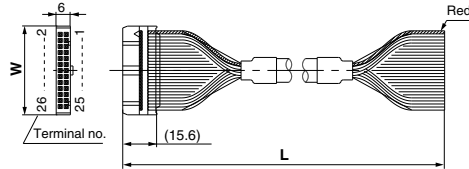

Connector manufacturers' example

- Hirose Electric Co., Ltd.
- Sumitomo 3M Limited
- Fujitsu Limited
- Japan Aviation Electronics Industry, Ltd.
- J.S.T. Mfg. Co., Ltd.

■ Connector cable for M12 waterproof connector (Female side)

Connector manufacturers' example
Correns Corp.
OMRON Corp.
Azbil Corp.
Hirose Electric Co., Ltd.
DDK Ltd.

■ SV1000/2000 and Series EX500 input unit DIN rail dimensions and mass

VZ1000 – 11 – 1 – □

* As for □, enter the number from the DIN rail dimensions table.

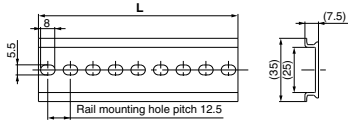

No.	0	1	2	3	4	5	6	7	8	9
L dimension	98	110.5	123	135.5	148	160.5	173	185.5	198	210.5
Mass (g)	17.6	19.9	22.1	24.4	26.6	28.9	31.1	33.4	35.6	37.9

No.	10	11	12	13	14	15	16	17	18	19
L dimension	223	235.5	248	260.5	273	285.5	298	310.5	323	335.5
Mass (g)	40.1	42.4	44.6	46.9	49.1	51.4	53.6	55.9	58.1	60.4

No.	20	21	22	23	24	25	26	27	28	29
L dimension	348	360.5	373	385.5	398	410.5	423	435.5	448	460.5
Mass (g)	62.5	64.9	67.1	69.4	71.6	73.9	76.1	78.4	80.6	82.9

No.	30	31	32	33	34	35	36	37	38	39
L dimension	473	485.5	498	510.5	523	535.5	548	560.5	573	585.5
Mass (g)	85.1	87.4	89.6	91.9	94.1	96.4	98.6	100.9	103.1	105.4

No.	40	41	42	43	44	45	46	47	48	49
L dimension	598	610.5	623	635.5	648	660.5	673	685.5	698	710.5
Mass (g)	107.6	109.9	112.1	114.4	116.6	118.9	121.1	123.4	125.6	127.9

No.	50	51	52	53	54	55	56	57	58	59
L dimension	723	735.5	748	760.5	773	785.5	798	810.5	823	835.5
Mass (g)	130.1	132.4	134.6	136.9	139.1	141.4	143.6	145.9	148.1	150.4

No.	60	61	62	63	64	65	66	67	68	69
L dimension	848	860.5	873	885.5	898	910.5	923	935.5	948	960.5
Mass (g)	152.6	154.9	157.1	159.4	161.6	163.9	166.1	168.4	170.6	172.9

No.	70	71
L dimension	973	985.5
Mass (g)	175.1	177.4

■ SV3000 and 4000 DIN rail dimensions and mass

VZ1000 – 11 – 4 – □

* As for □, enter the number from the DIN rail dimensions table.

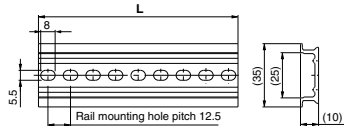

No.	0	1	2	3	4	5	6	7	8	9	10	11	12	13	14	15	16	17	18	19	20
L dimension	98	110.5	123	135.5	148	160.5	173	185.5	198	210.5	223	235.5	248	260.5	273	285.5	298	310.5	323	335.5	348
Mass (g)	24.8	28	31.1	34.3	37.4	40.6	43.8	46.9	50.1	53.3	56.4	59.6	62.7	65.9	69.1	72.2	75.4	78.6	81.7	84.9	88

No.	21	22	23	24	25	26	27	28	29	30	31	32	33	34	35	36	37	38	39	40	41
L dimension	360.5	373	385.5	398	410.5	423	435.5	448	460.5	473	485.5	498	510.5	523	535.5	548	560.5	573	585.5	598	610.5
Mass (g)	91.2	94.4	97.5	100.7	103.9	107	110.2	113.3	116.5	119.7	122.8	126	129.2	132.3	135.5	138.6	141.8	145	148.1	151.3	154.5

No.	42	43	44	45	46	47	48	49	50	51	52	53	54	55	56	57	58	59	60	61	62
L dimension	623	635.5	648	660.5	673	685.5	698	710.5	723	735.5	748	760.5	773	785.5	798	810.5	823	835.5	848	860.5	873
Mass (g)	157.6	160.8	163.9	167.1	170.3	173.4	176.6	179.8	182.9	186.1	189.2	192.4	195.6	198.7	201.9	205.1	208.2	211.4	214.5	217.7	220.9

No.	63	64	65	66	67	68	69	70	71
L dimension	885.5	898	910.5	923	935.5	948	960.5	973	985.5
Mass (g)	224	227.2	230.4	233.5	236.7	239.8	243	246.2	249.3

Manifold Options

How to order

SV1000-05-P-□

Pressure gauge option Note 1)

M1	Without pressure gauge
05	With MPa indication pressure gauge (For odd number station)
06	With MPa indication pressure gauge (For even number station)
N5	With psi indication pressure gauge (For odd number station) <small>Note 2)</small>
N6	With psi indication pressure gauge (For even number station) <small>Note 2)</small>

Applicable valve Note 3)

N11	For single, double, 4 position
3	For 3 position

Note 1) In the case of Series SV1000 with a pressure gauge when mounting on the manifold, use caution that the part numbers are different between the odd no. stations and the even no. stations to avoid pressure gauges from interfering from each others.

Note 2) The units with the psi indication are sold only overseas according to the new measurement law in Japan.
Note 3) For series SV1000, be careful as the part number for the single, double, and 4 position differs from that for the 3 position due to differences in valve length.

Additionally, when the valve with the pressure gauge is selected and at least one 3 position valve is included on the same manifold, use the 3 position valve for all manifolds to prevent interferences among pressure gauges.

SV2000-00-P

Series

2	SV2000
3	SV3000
4	SV4000

Regulating port

P	1(P) port
A1	4(A) port (P controlled type, A port regulation)
B1	2(B) port (P controlled type, B port regulation)

Pressure gauge option

M1	Without pressure gauge
00	With MPa indication pressure gauge <small>Note 2)</small>
N0	With psi indication pressure gauge <small>Note 2)</small>

SV1000-05-□
(For mounting odd number stations)

SV1000-06-□
(For mounting even number stations)

SV1000-M1-□

SV2000-00-□

SV2000-M1-□

SV3000-00-□

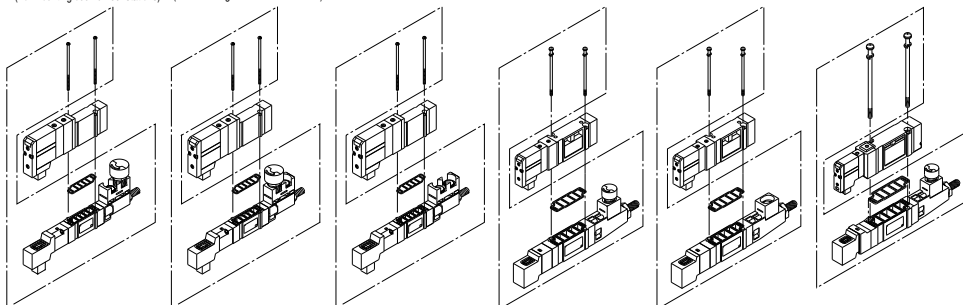

SV3000-M1-□

SV4000-00-□

SV4000-M1-□

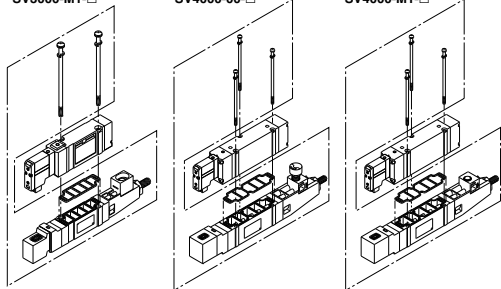

Symbol

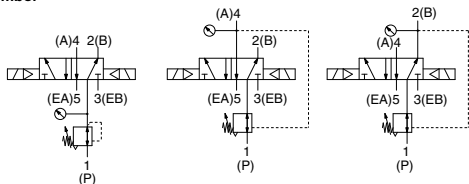

Accessory

Series	Round head combination screw	Gasket
SV1000	SX3000-22-9 (M2 x 39.5)	SX3000-57-4
SV2000	SV2000-21-7 (M3 x 53)	SX5000-57-6
SV3000	SV3000-21-4 (M4 x 57)	SX7000-57-5
SV4000	SV2000-21-8 (M3 x 69.5)	SY9000-11-2

Caution

Mounting Screw Tightening Torques

M2: 0.16 N-m
M3: 0.8 N-m
M4: 1.4 N-m

Manifold Option

■ Individual SUP spacer assembly

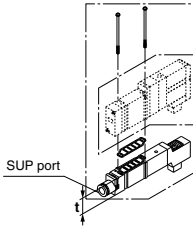

■ Individual EXH spacer assembly

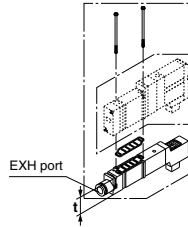

How to order individual SUP/EXH spacer assembly

Series SV1000

SV1000 - **38** - **1A** - **C6**

* t: 15

Series SV2000/SV3000/SV4000

SV **2** 000 - **38** - 1 **A**

● Port size

C3	One-touch fitting for $\phi 3.2$
C4	One-touch fitting for $\phi 4$
C6	One-touch fitting for $\phi 6$
N1	One-touch fitting for $\phi 1/8"$
N3	One-touch fitting for $\phi 5/32"$
N7	One-touch fitting for $\phi 1/4"$

● Series

Symbol	Series	t
2	SV2000	15
3	SV3000	18.5
4	SV4000	20

● Thread type ^{Note)}

NH	Rc
F	G
N	NPT
T	NPTF

● Spacer type

38	Individual SUP spacer
39	Individual EXH spacer
88	Individual SUP + Individual EXH spacers (Double-stack)

* In the series SV3000, only type 10 is compatible with the double-stack spacers.
The series SV4000 is not compatible with the double-stack spacers.
Individual SUP and EXH spacers can be mounted either on the top or the bottom.

Note) SV2000/3000/4000 port size

Series	Port size
SV2000	1/8
SV3000	1/8
SV4000	1/4

Series	Round head combination screw	Gasket
SV1000	SX3000-22-9 (M2 x 39.5)	SX3000-57-4
SV2000	SV2000-21-6 (M3 x 46)	SY5000-11-15
SV3000	SV3000-21-3 (M4 x 53)	SY7000-11-11
SV4000	SV2000-21-5 (M3 x 60)	SY9000-11-2

■ Individual SUP/EXH spacer assembly (Double-stack)

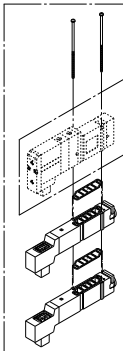

SJ
SY
SY
SV
SYJ
SZ
VF
VP4
S0700
VQ
VQ4
VQ5
VQC
VQC4
VQZ
SQ
VFS
VFR
VQ7

Single Valve/Sub-plate Type IP67 Compliant Series SV1000/2000/3000/4000



How to Order

SV 1 1 00 - 5 W1 U D - - -

Series

1	SV1000
2	SV2000
3	SV3000
4	SV4000

Made to order

Nil	—
X90	Main valve fluororubber (Refer to page 646.)

Type of actuation

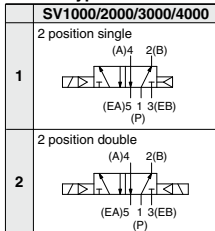

Pilot type

Nil	Internal pilot
R	External pilot

* External pilot specifications is not available for 4 position dual 3 port valves.

Thread type

Nil	Rc
F	G
N	NPT
T	NPTF

Port size

Symbol	Port size	Applicable series
Nil	Without sub-plate	
01	1/8	SV1000
02	1/4	SV2000 SV3000
03	3/8	SV3000 SV4000
04	1/2	SV4000

Manual override

Nil	Non-locking push type
D	Push-turn locking slotted type

Light/Surge voltage suppressor

U	With light/surge voltage suppressor
R	With surge voltage suppressor

M12 waterproof connector

Symbol	Cable length (mm)
W1	300
W2	500
W3	1000
W4	2000
W7	5000

Rated voltage

5	24 VDC
6	12 VDC

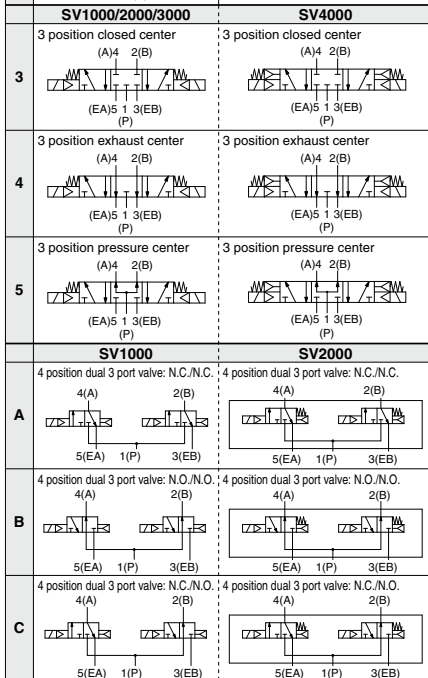

* SV3000 and 4000 are not available with 4 position dual 3 port valve.

Series SV Solenoid Valve Specifications



Fluid		Air
Internal pilot operating pressure range (MPa)	2 position single	0.15 to 0.7
	4 position dual 3 port valve	
	2 position double	0.1 to 0.7
External pilot operating pressure range (MPa)	3 position	0.2 to 0.7
	Operating pressure range	-100 kPa to 0.7
Ambient and fluid temperature (°C)	2 position single, double	-10 to 50 (No freezing. Refer to page 5.)
	4 position dual 3 port valve	
Max. operating frequency (Hz)	2 position	5
	3 position	3
	Manual override	Non-locking push type Push-turn locking slotted type
Pilot exhaust method	Internal pilot	Common exhaust type for main and pilot valve
	External pilot	
Lubrication		Not required
Mounting orientation		Unrestricted
Impact/Vibration resistance (ms²)		150/30 (8.3 to 2000 Hz)
Enclosure		IP67 (Based on IEC60529)
Electrical entry		M12 waterproof connector
Coil rated voltage		24 VDC, 12 VDC
Allowable voltage fluctuation		±10% of rated voltage
Power consumption (W)		0.6 (With indicator light: 0.65)
Surge voltage suppressor		Zener diode
Indicator light		LED

Note) Impact resistance: No malfunction occurred when it is tested with a drop tester in the axial direction and at the right angles to the main valve and armature in both energized and de-energized states every once for each condition. (Values at the initial period)

Vibration resistance: No malfunction occurred in a one-sweep test between 45 and 2000 Hz. Test was performed at both energized and de-energized states in the axial direction and at the right angles to the main valve and armature. (Values at the initial period)

Response Time

Type of actuation	Response time (ms) (at the pressure of 0.5 MPa)			
	SV1000	SV2000	SV3000	SV4000
2 position single	11 or less	25 or less	28 or less	40 or less
2 position double	10 or less	17 or less	26 or less	40 or less
3 position	18 or less	29 or less	32 or less	82 or less
4 position dual 3 port valve	15 or less	33 or less	—	—

Note) Based on dynamic performance test, JIS B 8375-1981. (Coil temperature: 20°C, at rated voltage)

M12 Waterproof Connector Wiring Specifications

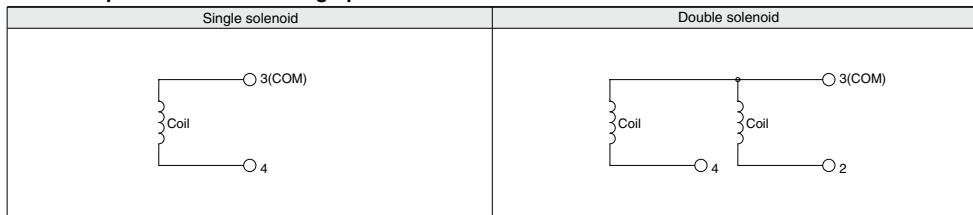

Note) Solenoid valves have no polarity.

Connection Destination (Female Side) Connector Cable

Connector size	pin	Manufacturer	Applicable series
M12	4	Correns Corp.	VA-4D
		OMRON Corp.	XS2
		Azbil Corp.	PA5-41
		Hirose Electric Co., Ltd.	HR24
		DDK Ltd.	CM01-8DP4S

* This connector is a female connector for ① relay output module and ② single unit/sub-plate.

SJ
SY
SY
SV
SVJ
SZ
VF
VP4
S0700
VQ
VQ4
VQ5
VQC
VQC4
VQZ
SQ
VFS
VFR
VQ7

Flow Characteristics/Weight

Series SV1000

Valve model	Type of actuation		Port size	Flow characteristics ⁽¹⁾						Weight (g) ⁽²⁾
				1 → 4/2 (P → A/B)			4/2 → 5/3 (A/B → EA/EB)			M12 waterproof connector (Cable length 300 mm)
				C [dm ³ /(s·bar)]	b	Cv	C [dm ³ /(s·bar)]	b	Cv	
SV1□00-□-01	2 position	Single	Rc 1/8	1.0	0.30	0.24	1.1	0.30	0.26	123 (88)
		Double								128 (93)
	3 position	Closed center		0.77	0.28	0.18	0.85	0.30	0.19	130 (95)
		Exhaust center		0.73	0.31	0.18	1.1 [0.55]	0.26 [0.52]	0.24 [0.16]	
		Pressure center		1.2 [0.51]	0.24 [0.45]	0.29 [0.14]	0.89	0.47	0.24	
		N.C./N.C.		0.68	0.35	0.18	1.1	0.39	0.29	
	4 position dual	N.O./N.O.		0.87	0.31	0.23	0.77	0.44	0.21	128 (93)

Note 1) []: Denotes the normal position. Note 2) (): Denotes without sub-plate.

Series SV2000

Valve model	Type of actuation		Port size	Flow characteristics ⁽¹⁾						Weight (g) ⁽²⁾
				1 → 4/2 (P → A/B)			4/2 → 5/3 (A/B → EA/EB)			M12 waterproof connector (Cable length 300 mm)
				C [dm ³ /(s·bar)]	b	Cv	C [dm ³ /(s·bar)]	b	Cv	
SV2□00-□-02	2 position	Single	Rc 1/4	2.4	0.41	0.64	2.8	0.29	0.66	159 (96)
		Double								163 (100)
	3 position	Closed center		1.8	0.47	0.50	1.8	0.40	0.47	168 (105)
		Exhaust center		1.4	0.55	0.44	3.0 [1.2]	0.33 [0.48]	0.72 [0.37]	
		Pressure center		3.3 [0.84]	0.36 [0.60]	0.85 [0.28]	1.8	0.40	0.48	
		N.C./N.C.		2.2	0.40	0.55	2.6	0.31	0.60	
	4 position dual	N.O./N.O.		2.7	0.24	0.57	2.3	0.36	0.54	163 (100)

Note 1) []: Denotes the normal position. Note 2) (): Denotes without sub-plate.

Series SV3000

Valve model	Type of actuation		Port size	Flow characteristics ⁽¹⁾						Weight (g) ⁽²⁾
				1 → 4/2 (P → A/B)			4/2 → 5/3 (A/B → EA/EB)			M12 waterproof connector (Cable length 300 mm)
				C [dm ³ /(s·bar)]	b	Cv	C [dm ³ /(s·bar)]	b	Cv	
SV3□00-□-02	2 position	Single	Rc 1/4	4.1	0.41	1.1	4.1	0.29	1.0	250 (121)
		Double								253 (124)
	3 position	Closed center		3.0	0.43	0.80	2.6	0.41	0.72	26 (132)
		Exhaust center		2.6	0.42	0.71	4.7 [1.7]	0.35 [0.48]	1.1 [0.49]	
		Pressure center		5.3 [2.3]	0.39 [0.49]	1.3 [0.65]	2.2	0.49	0.63	
		N.C./N.C.		4.9	0.29	1.2	4.5	0.27	1.1	
SV3□00-□-03	2 position	Single	Rc 3/8	3.0	0.40	0.80	2.6	0.45	0.73	235
		Double								238
	3 position	Closed center		2.6	0.42	0.71	4.8 [1.7]	0.35 [0.48]	1.1 [0.34]	246
		Pressure center		5.3 [2.3]	0.31 [0.51]	1.3 [0.64]	2.3	0.45	0.66	

Note 1) []: Denotes the normal position. Note 2) (): Denotes without sub-plate.

Series SV4000

Valve model	Type of actuation		Port size	Flow characteristics ⁽¹⁾						Weight (g) ⁽²⁾
				1 → 4/2 (P → A/B)			4/2 → 5/3 (A/B → EA/EB)			M12 waterproof connector (Cable length 300 mm)
				C [dm ³ /(s·bar)]	b	Cv	C [dm ³ /(s·bar)]	b	Cv	
SV4□00-□-03	2 position	Single	Rc 3/8	7.9	0.34	2.0	9.6	0.43	2.5	505 (208)
		Double								509 (212)
	3 position	Closed center		7.5	0.33	1.8	7.3	0.30	1.7	530 (233)
		Exhaust center		7.2	0.34	1.7	13 [4.0]	0.23 [0.41]	2.8 [0.95]	
		Pressure center		12 [3.3]	0.26 [0.41]	2.8 [0.84]	6.7	0.40	1.9	
SV4□00-□-04	2 position	Single	Rc 1/2	8.0	0.48	2.2	10	0.29	2.5	484
		Double								488
	3 position	Closed center		7.6	0.32	1.8	7.3	0.32	1.8	509
		Exhaust center		7.3	0.42	2.0	13 [4.7]	0.32 [0.54]	3.6 [1.5]	
		Pressure center		12 [3.3]	0.33 [0.51]	3.3 [0.94]	7.4	0.33	1.9	

Note 1) []: Denotes the normal position. Note 2) (): Denotes without sub-plate.

Construction: SV1000/2000/3000/4000 Single Valve/Sub-plate Type

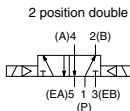
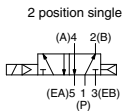

SV1000/2000/3000

3 position closed center

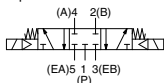

3 position exhaust center



3 position pressure center

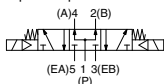

SV4000

3 position closed center

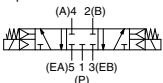

3 position exhaust center

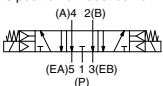

3 position pressure center

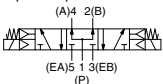

2 position single

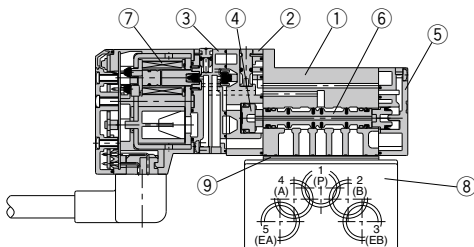

2 position double

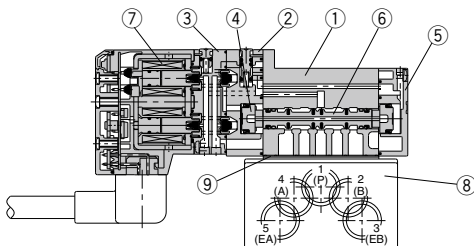

3 position closed center/exhaust center/pressure center

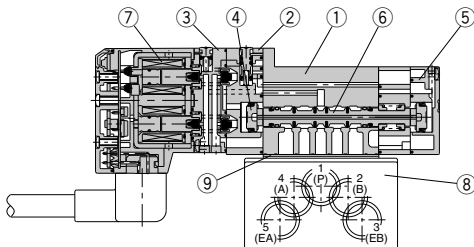

Component Parts

No.	Description	Material	Note
①	Body	Aluminum die-casted (SV1000 is zinc die-casted)	White
②	Adapter plate	Resin	White
③	Pilot body	Resin	White
④	Piston	Resin	—
⑤	End plate	Resin	White
⑥	Spool valve assembly	Aluminum/HNBR	—
⑦	Molded coil	—	Gray

Caution

Mounting screw tightening torques

M2: 0.16 N·m
M3: 0.8 N·m
M4: 1.4 N·m

Replacement Parts

No.	Description	Part no.				Note
		SV1□00	SV2□00	SV3□00	SV4□00	
⑧	Sub-plate	SY3000-27-1□-Q	SY5000-27-1□-Q	1/4: SY7000-27-1□-Q 3/8: SY7000-27-2□-Q	3/8: SY9000-27-1□ 1/2: SY9000-27-2□	Aluminum die-casted Refer to thread types on page 638 for □.
⑨	Gasket	SY3000-11-25	SY5000-11-18	SY7000-11-14	SY9000-11-2	
—	Round head combination screw	SX3000-22-2 (M2 x 24)	SV2000-21-1 (M3 x 30)	SV3000-21-1 (M4 x 35)	SV2000-21-2 (M3 x 40)	For valve mounting (Matt nickel plated)

Note) Round head combination screw requires 2 pcs. per one valve for Series SV1000, SV2000, SV3000. For Series SV4000, it requires 3 pcs.

SV
SVJ
SZ
VF
VP4
S0700
VQ
VQ4
VQ5
VQC
VQC4
VQZ
SQ
VFS
VFR
VQ7

Dimensions: Series SV1000

2 position single/double, 4 position dual 3 port [M12 waterproof connector type]

SV1□00(R)-□W□□-01□

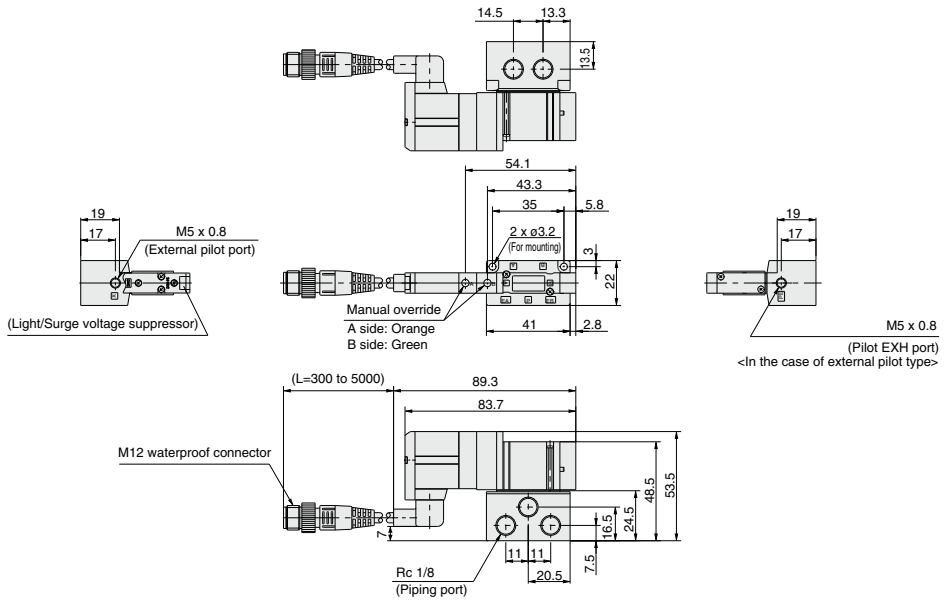

3 position closed center/exhaust center/pressure center [M12 waterproof connector type]

SV1□00(R)-□W□□-01□

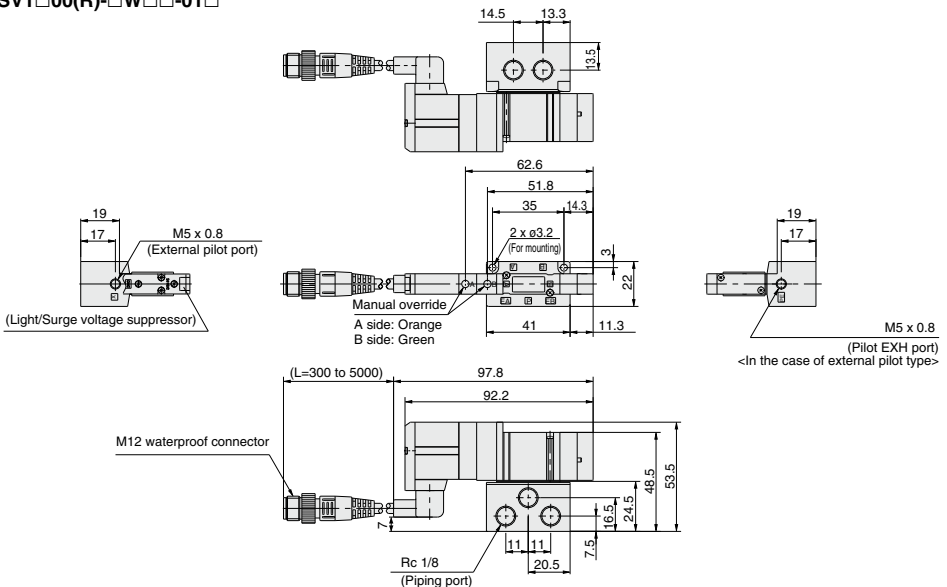

Dimensions: Series SV2000

2 position single/double, 4 position dual 3 port [M12 waterproof connector type]
SV2□00(R)-□W□□-02□

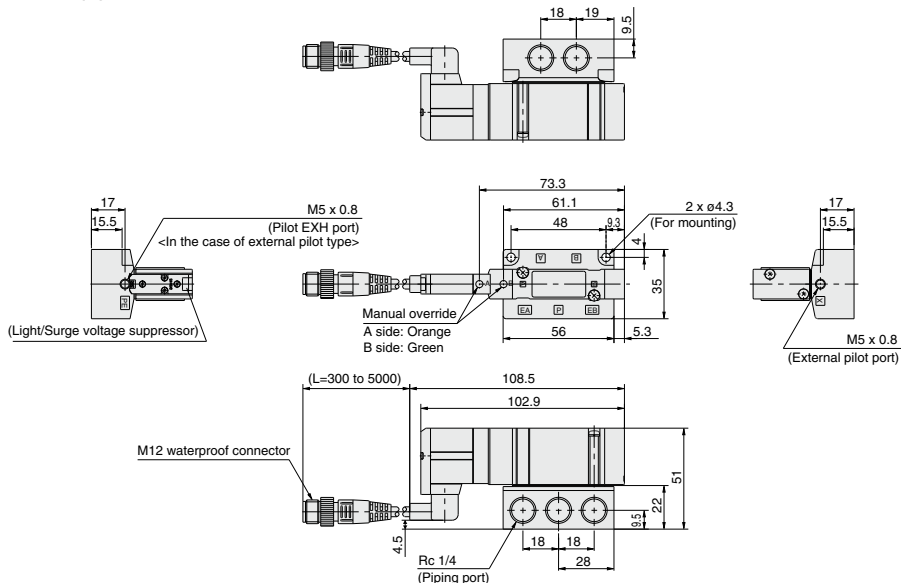

3 position closed center/exhaust center/pressure center [M12 waterproof connector type]
SV2□00(R)-□W□□-02□

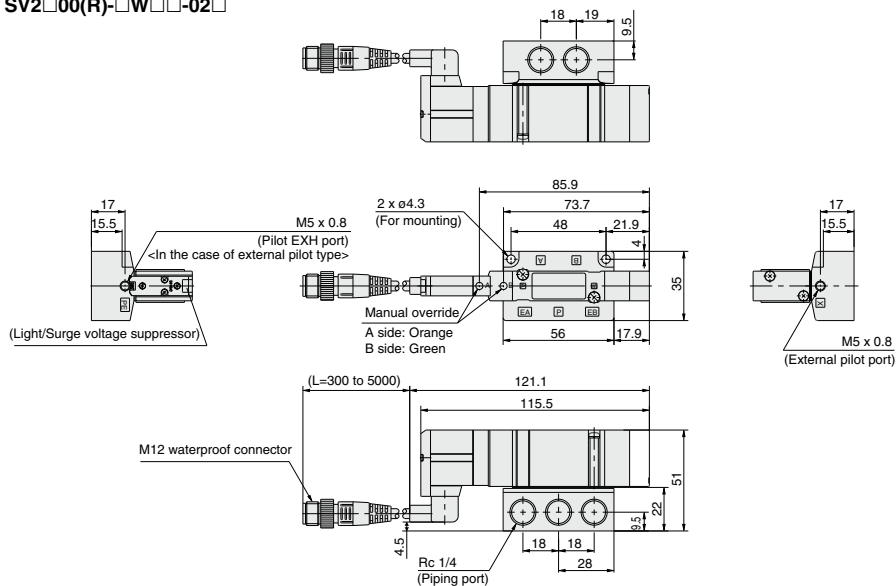

SJ
SY
SY
SV
SYJ
SZ
VF
VP4
S0700
VQ
VQ4
VQ5
VQC
VQC4
VQZ
SQ
VFS
VFR
VQ7

Dimensions: Series SV3000

2 position single/double [M12 waterproof connector type]

SV3□00(R)-□W□□-02, 03□

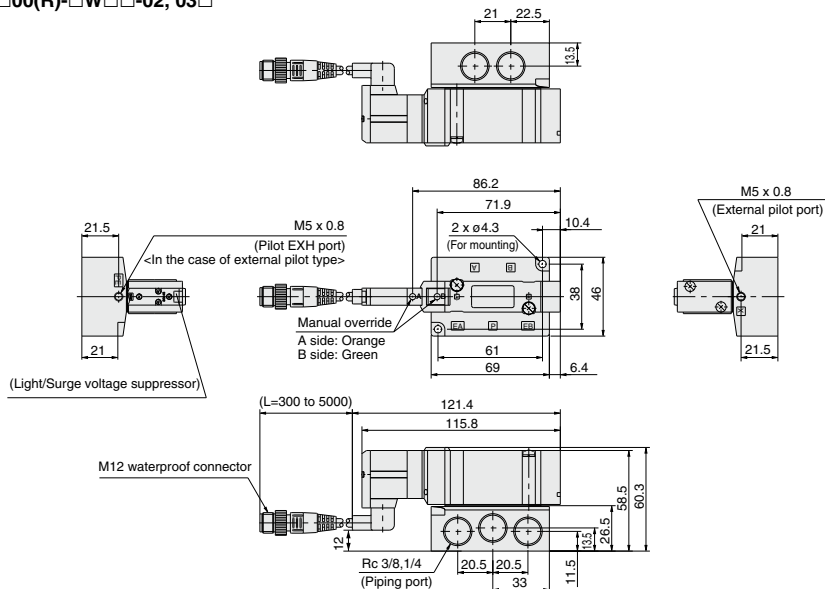

3 position closed center/exhaust center/pressure center [M12 waterproof connector type]

SV3□00(R)-□W□□-02, 03□

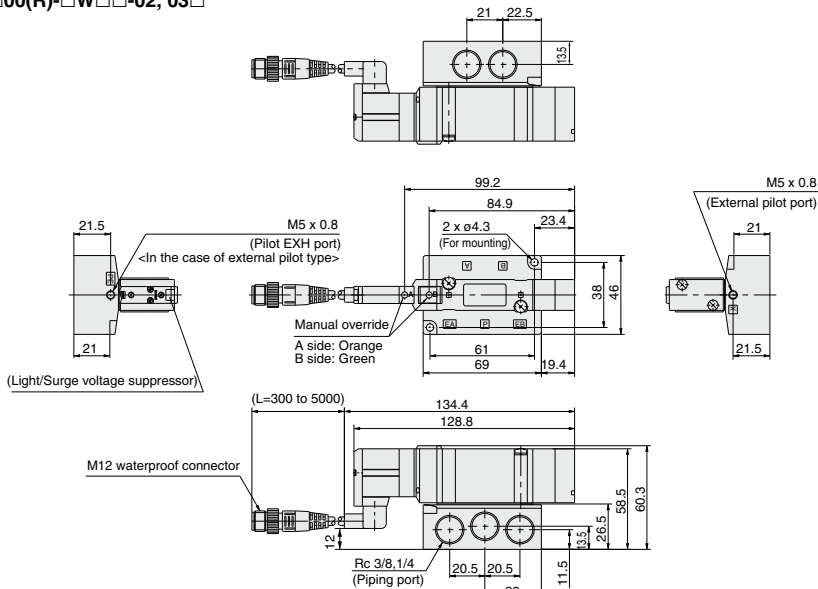

Dimensions: Series SV4000

2 position single/double [M12 waterproof connector type]

SV4□00(R)-□W□□-03, 04□

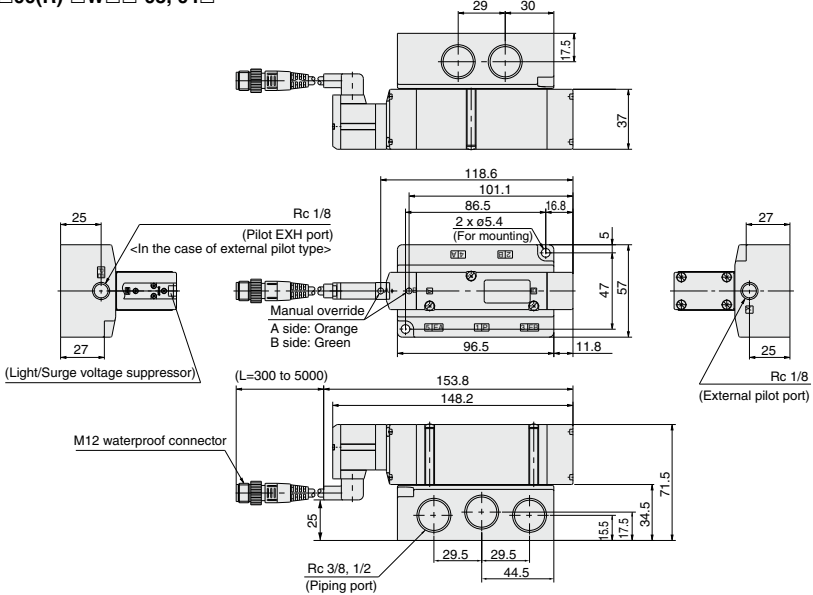

3 position closed center/exhaust center/pressure center [M12 waterproof connector type]

SV4□00(R)-□W□□-03, 04□

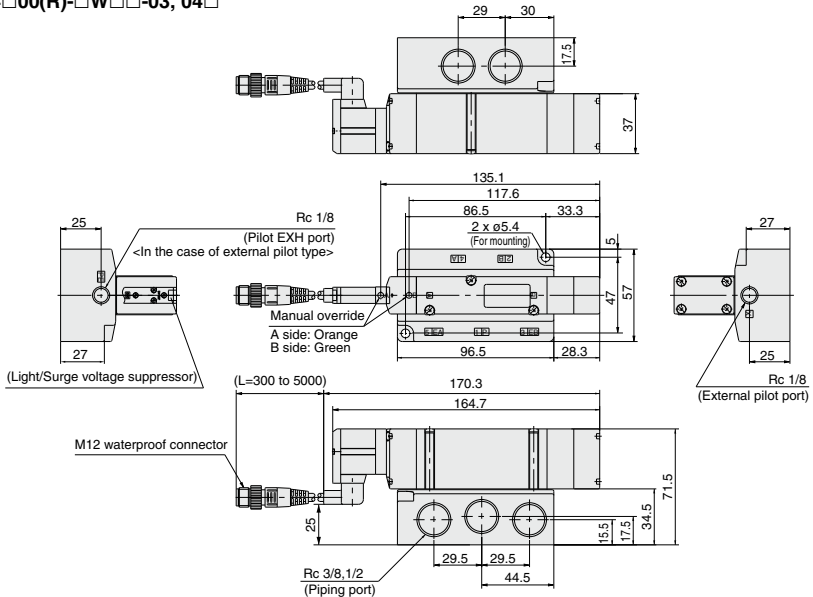

SJ
SY
SY
SV
SYJ
SZ
VF
VP4
S0700
VQ
VQ4
VQ5
VQC
VQC4
VQZ
SQ
VFS
VFR
VQ7



Please contact SMC for detailed dimensions, specifications and lead times.

1 Main Valve Fluororubber Specifications

Symbol

-X90

Fluororubber is used for rubber parts of the main valve to allow use in applications such as the following.

1. When using a lubricant other than the recommended turbine oil, and there is a possibility of malfunction due to swelling of the spool valve seats.
2. When ozone enters or is generated in the air supply.

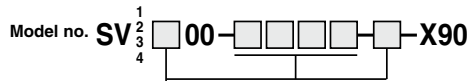

• Entry is the same as standard products.

Note) Because in series -X90 fluororubber is used for only main valve, the rubber parts of the application/usage in conditions requiring heat resistance should be avoided.



Series SV

Specific Product Precautions 1

Be sure to read before handling.

Refer to front matter 53 for Safety Instructions and pages 3 to 8 for 3/4/5 Port Solenoid Valve Precautions.

Environment

Warning

- Do not use valves in atmospheres of corrosive gases, chemicals, salt water, water, steam, or where there is direct contact with any of these.
- Products compliant with IP65 and IP67 enclosures (Based on IEC60529) are protected against dust and water, however, these products cannot be used in water.
- Products compliant with IP65 and IP67 enclosures satisfy the specifications by mounting each product properly. Be sure to read the Specific Product Precautions for each product.
- When using built-in silencer type manifold with an IP67 enclosure, keep the exhaust port of the silencer from coming in direct contact with water or other liquids. Liquid filtration through the exhaust port of the silencer can cause damage to the valve.

Manual Override Operation

Warning

Handle carefully, as connected equipment can be actuated through manual override operation.

■ Non-locking push type

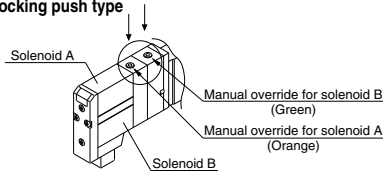

■ Push-turn locking slotted type

After pushing down, turn in the direction of the arrow. If it is not turned, it can be operated the same way as the non-locking type.

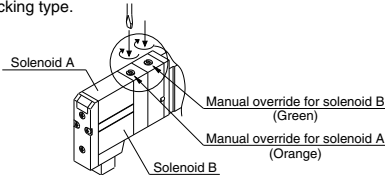

Caution

When locking the manual override with the push-turn locking slotted type, be sure to push it down before turning. Turning without first pushing it down can cause damage to the manual override and other trouble such as air leakage, etc.

Exhaust Restriction

Caution

Since Series SV is a type in which the pilot valve exhaust joins the main valve exhaust inside the valve, use caution, so that the piping from the exhaust port is not restricted.

Series SV Used as a 3 Port Valve

Caution

In the case of using a 5 port valve (as a 3 port valve)
Series SV can be used as normally closed (N.C.) or normally open (N.O.) 3 port valves by closing one of the cylinder ports (A or B) with a plug. However, they should be used with the exhaust ports kept open. They are convenient at times when a double solenoid type 3 port valve is required.

Plug position		B port	A port
Actuation		N.C.	N.O.
Number of solenoids	Single		
	Double		

Light/Surge Voltage Suppressor

Caution

Solenoid valves have no polarity. Light/Surge voltage suppressor

Single solenoid

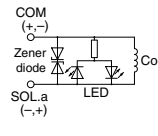

Double solenoid, 3 position type

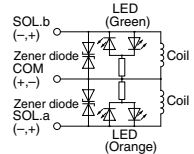

Surge voltage suppressor

Single solenoid

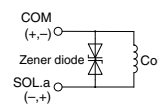

Double solenoid, 3 position type

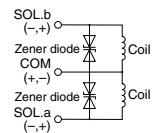

Light Indication

Caution

When equipped with indicator light and surge voltage suppressor, the light window turns orange when solenoid A is energized, and it turns green when solenoid B is energized.

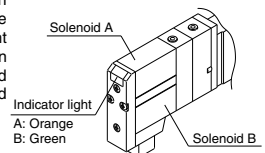

SJ

SY

SY

SV

SYJ

SZ

VF

VP4

S0700

VQ

VQ4

VQ5

VQC

VQC4

VQZ

SQ

VFS

VFR

VQ7



Series SV Specific Product Precautions 2

Be sure to read before handling.

Refer to front matter 53 for Safety Instructions and pages 3 to 8 for 3/4/5 Port Solenoid Valve Precautions.

Connector Entry Directions

⚠ Caution

Connector entry directions for D-sub connectors and flat ribbon cables can be changed. To change the connector's entry direction, press the levers on both sides of the connector, take it off, and change the direction as shown in the drawing. Since lead wire assemblies are attached to the connector, excessive pulling or twisting can cause broken wires or other trouble. Also, take precautions so that lead wires are not caught and pinched when installing the connector.

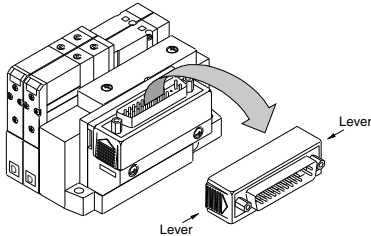

How to Order Manifold

⚠ Caution

The letter "S" or "D" is indicated on manifold blocks for series SV as shown below. This indication refers to the type of substrate assembly (single wiring or double wiring) inside the manifold blocks.

When the manifold specification sheet does not include a wiring specification, all stations will be double wiring specification (D). In this case, single and double solenoid valves can be mounted in any position, but when a single valve is used, there will be an unused control signal. To avoid this, indicate positions of manifold blocks for single wiring specification (S) and double wiring specification (D) on a manifold specification sheet. (Note that double, 3 or 4 position valves cannot be used for manifold blocks with single wiring specification (S).)

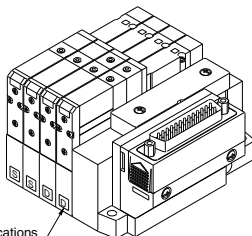

Substrate Assemblies inside Manifolds

⚠ Caution

Substrate assemblies inside of manifolds cannot be taken apart. Attempting to do so may damage parts.

One-touch Fittings

⚠ Caution

1. Tube attachment/detachment for One-touch fittings

1) Attaching of tube

- (1) Take a tube having no flaws on its periphery and cut it off at a right angle. When cutting the tube, use tube cutters TK-1, 2 or 3. Do not use pinchers, nippers or scissors, etc. If cutting is done with tools other than tube cutters, there is the danger that the tube may be cut diagonally or become flattened, etc., making a secure installation impossible, and causing problems such as the tube pulling out after installation or air leakage. Also allow some extra length in the tube.
- (2) Grasp the tube and push it in slowly, inserting it securely all the way into the fitting.
- (3) After inserting the tube, pull on it lightly to confirm that it will not come out. If it is not installed securely all the way into the fitting, this can cause problems such as air leakage or the tube pulling out.

2) Detaching of tube

- (1) Push in the release button sufficiently, and push the collar evenly at the same time.
- (2) Pull out the tube while holding down the release button so that it does not come out. If the release button is not pressed down sufficiently, there will be increased bite on the tube and it will become more difficult to pull it out.
- (3) When the removed tube is to be used again, cut off the portion which has been chewed before reusing it. If the chewed portion of the tube is used as is, this can cause trouble such as air leakage or difficulty in removing the tube.

Other Tubing Brands

⚠ Caution

1. When using tube other than SMC brand, confirm that the following specifications are satisfied with respect to the outside diameter tolerance of the tube.

- | | |
|------------------------|---------------------------------------|
| 1) Nylon tubing | within ± 0.1 mm |
| 2) Soft nylon tubing | within ± 0.1 mm |
| 3) Polyurethane tubing | within $+0.15$ mm
within -0.2 mm |

Do not use tubing which does not meet these outside diameter tolerances. It may not be possible to connect them, or they may cause other trouble, such as air leakage or the tube pulling out after connection.

Back Pressure Check Valve Built-in Type

⚠ Caution

Valves with built-in back pressure check valve is to protect the back pressure inside a valve. For this reason, use caution the valves with external pilot specification cannot be pressurized from exhaust port [3/5(E)]. As compared with the types which do not integrate the back pressure check valve, C value of the flow characteristics goes down. For details, please contact SMC.



Series SV Specific Product Precautions 3

Be sure to read before handling.

Refer to front matter 53 for Safety Instructions and pages 3 to 8 for 3/4/5 Port Solenoid Valve Precautions.

Interface Regulator

Caution

Specifications

Interface regulator		SV1□□00-□-□	SV2000-□-□	SV3000-□-□	SV4000-□-□
Applicable model		SV1000	SV2000	SV3000	SV4000
Regulating port		P, A, B			
Set pressure range		0.1 to 0.7 MPa			
Maximum operating pressure		0.7 MPa			
Fluid		Air			
Ambient and fluid temp.		Maximum at 50°C			
Weight	With pressure gauge	38.4 g (43.4 g)	86.5 g	103.8 g	178.2 g
	Without pressure gauge	32 g (37 g)	80.3 g	97.6 g	171.8 g

Note 1) Apply pressure from P port in the base for interface regulator.

Note 3) Gasket and mounting screws are included in the weight.

Note 2) P port pressure regulation is only available for closed center and pressure center.

Note 4) () : Denotes the values of SV1300.

Flow Characteristics

SV1000 P Reduced pressure (P → A,B)

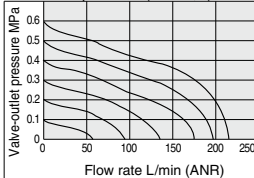

SV2000 P Reduced pressure (P → A,B)

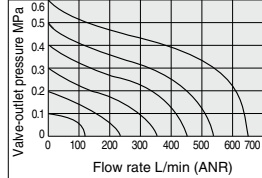

A1 Reduced pressure (P → A), B1 Reduced pressure (P → B)

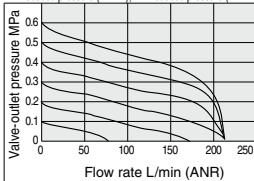

A1 Reduced pressure (P → A), B1 Reduced pressure (P → B)

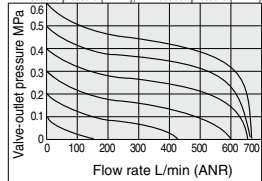

SV3000 P Reduced pressure (P → A,B)

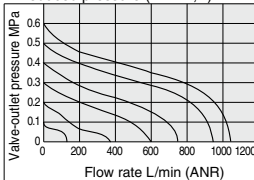

A1 Reduced pressure (P → A), B1 Reduced pressure (P → B)

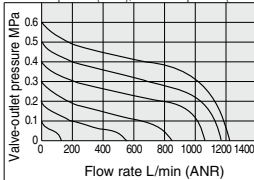

How to Calculate the Flow Rate

For obtaining the flow rate, refer to front matters 42 to 45

SJ
SY
SY
SV
SYJ
SZ
VF
VP4
S0700
VQ
VQ4
VQ5
VQC
VQC4
VQZ
SQ
VFS
VFR
VQ7



Series SV

Specific Product Precautions 4

Be sure to read before handling.

Refer to front matter 53 for Safety Instructions and pages 3 to 8 for 3/4/5 Port Solenoid Valve Precautions.

Serial Wiring EX500/EX250/EX260/EX120 Precautions

Warning

1. These products are intended for use in general factory automation equipment.
Avoid using these products in machinery/equipment which affects human safety, and in cases where malfunction or failure can result in extensive damage.
2. Do not use in an explosive atmosphere, environment with inflammable gases, or corrosive atmosphere.
This can cause injury or fire, etc.
3. Work such as transporting, installing, piping, wiring, operation, control and maintenance should be performed by personnel with specialized knowledge.
There is a danger of electrocution, injury or fire, etc.
4. Install an external emergency stop circuit that can promptly stop operation and shut off the power supply.
5. Do not remodel these products, as there is a danger of injury and damage.
6. Do not wipe the product with chemicals, etc.

Caution

1. Read the instruction manual carefully, strictly observe the precautions and operate within the range of the specifications.
2. Do not drop these products or submit them to strong impacts. This can cause damage, failure or malfunction, etc.
3. In locations with poor electrical conditions, take steps to ensure a steady flow of the rated power supply. Use of a voltage outside of the specifications can cause malfunction, damage to the unit, electrocution or fire, etc.
4. Do not touch connector terminals or internal substrates when current is being supplied. There is a danger of malfunction, damage to the unit or electrocution if connector terminals or internal substrates are touched when current is being supplied.
Be sure that the power supply is OFF when adding or removing manifold valves or input blocks, etc., or when connecting or disconnecting connectors.
5. Operate at an ambient temperature that is within the specifications. Even when the ambient temperature range is within the specifications, do not use in locations where there are rapid temperature changes.
6. Keep wire scraps and other extraneous material from getting inside these products. This can cause fire, failure or malfunction, etc.
7. Give consideration to the operating environment depending on the type of enclosure being used.
To achieve IP65 or IP67 protection, provide appropriate wiring between all units using electrical wiring cables, communication connectors and cables with M12 connectors. Also, provide waterproof caps when there are unused ports, and perform proper mounting of input units, input blocks, SI units and manifold valves, etc. Provide a cover or other protection for applications in which there is constant exposure to water.
8. Obey the proper tightening torque.
There is a possibility of damaging threads if tightening exceeds the tightening torque range.

Caution

9. Provide adequate protection when operating in locations such as the following:
 - Where noise is generated by static electricity, etc.
 - Where there is a strong electric field
 - Where there is a danger of exposure to radiation
 - When in close proximity to power supply lines
10. When these products are installed in equipment, provide adequate protection against noise by using noise filters, etc.
11. Since these products are components that are used after installation in other equipment, the customer should confirm conformity to EMC directives for the finished product.
12. Do not remove the name plate.
13. Perform periodic inspections and confirm normal operation. It may otherwise be impossible to guarantee safety due to unexpected malfunction or erroneous operation.

Power Supply Safety Instructions

Caution

1. Operation is possible with a single power supply or a separate power supply. However, be sure to provide two wiring systems (one for solenoid valves, and one for input and control units).
2. Use the following UL approved products for DC power supply combinations.
 - 1) Controlled voltage current circuit conforming to UL508
Circuit uses the secondary coil of an isolated transformer as the power supply, satisfying the following conditions.
 - Max. voltage (with no load): 30 Vrms (42.4 V peak) or less
 - Max. current: (1) 8 A or less (including shorts), and
(2) When controlled by a circuit protector (fuse, etc.) with the following rating

No-load voltage (V peak)	Max. current rating
0 to 20 [V]	5.0
Over 20 [V] to 30 [V]	100
	Peak voltage value
 - 2) A circuit (class 2 circuit) with maximum 30 Vrms (42.4 V peak) or less, and a power supply consisting of a class 2 power supply unit conforming to UL1310, or a class 2 transformer conforming to UL1585

Safety Instructions for Cable

Caution

1. Be careful of mis-wiring. This can cause malfunction, damage and fire in the unit.
2. To prevent noise and surge in signal lines, keep all wiring separate from power lines and high voltage lines. Otherwise, this can cause malfunction.
3. Check wiring insulation, as defective insulation can cause damage to the unit due to excessive voltage or current.
4. Do not bend or pull cables repeatedly, and do not place heavy objects on them or allow them to be pinched. This can cause broken lines.



Series SV

Specific Product Precautions 5

Be sure to read before handling.

Refer to front matter 53 for Safety Instructions and pages 3 to 8 for 3/4/5 Port Solenoid Valve Precautions.

EX600 Precautions

Design/Selection

Warning

- Use this product within the specification range.**
Using beyond the specified specifications range can cause fire, malfunction, or damage to the system.
Confirm the specifications when operating.
- When using for an interlock circuit:**
 - Provide a multiple interlock system which is operated by another system (such as mechanical protection function).
 - Perform an inspection to check that it is working properly.

This may cause possible injury due to malfunction.

Caution

- When applicable to UL, use a Class 2 power supply unit conforming to UL1310 for direct current power supply.**
- Use this product within the specified voltage range.**
Using beyond the specified voltage range is likely to cause the units and connecting devices to be damaged or to malfunction.
- The power supply for the unit should be 0 V as the standard for both power supply for output as well as power supply for control/input.**

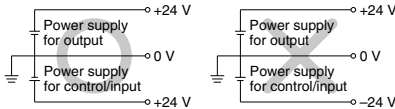

- Do not install a unit in a place where it can be used as a foothold.**
Applying any excessive load such as stepping on the unit by mistake or placing a foot on it, will cause it to break.
- Keep the surrounding space free for maintenance.**
When designing a system, take into consideration the amount of free space needed for performing maintenance.
- Do not remove the name plate.**
Improper maintenance or incorrect use of operation manual can cause failure and malfunction. Also, there is a risk of losing conformity with safety standards.
- Beware of inrush current when the power supply is turned on.**
Some connected loads can apply an initial charge current which will trigger the over current protection function, causing the unit to malfunction.

Mounting

Caution

- When handling and assembling units:**
 - Do not touch the sharp metal parts of the connector or plug.
 - Do not apply excessive force to the unit when disassembling.
The connecting portions of the unit are firmly joined with seals.
 - When joining units, take care not to get fingers caught between units.
Injury can result.

Mounting

Caution

- Do not drop, bump, or apply excessive impact.**
Otherwise, the unit can become damaged, malfunction, or fail to function.
- Observe the tightening torque range.**
Tightening outside of the allowable torque range will likely damage the screw.
IP67 cannot be guaranteed if the screws are not tightened to the specified torque.
- When lifting a large size manifold solenoid valve unit, take care to avoid causing stress to the valve connection joint.**
The connection parts of the unit may be damaged.
Because the unit may be heavy, carrying and installation should be performed by more than one operator to avoid strain or injury.
- When placing a manifold, mount it on a flat surface.**
Torsion in the whole manifold can lead to trouble such as air leakage or defective insulation.

Wiring

Caution

- Confirm grounding to maintain the safety of the reduced wiring system and for anti-noise performance.**
Provide a specific grounding as close to the unit as possible to minimize the distance to grounding.
- Avoid repeatedly bending or stretching the cable and applying a heavy object or force to it.**
Wiring applying repeated bending and tensile stress to the cable can break the circuit.
- Avoid miswiring.**
If miswired, there is a danger of malfunction or damage to the reduced wiring system.
- Do not wire while energizing the product.**
There is a danger of malfunction or damage to the reduced wiring system or input/output equipment.
- Avoid wiring the power line and high pressure line in parallel.**
Noise or surge produced by signal line resulting from the power line or high pressure line could cause malfunction.
Wiring of the reduced wiring system or input/output device and the power line or high pressure line should be separated from each other.
- Confirm the wiring insulation.**
Defective insulation (contact with other circuits, improper insulation between terminals, etc.) may cause damage to the reduced wiring system or input/output device due to excessive voltage or current.

SJ
SY
SY
SV
SYJ
SZ
VF
VP4
S0700
VQ
VQ4
VQ5
VQC
VQC4
VQZ
SQ
VFS
VFR
VQ7



Series SV

Specific Product Precautions 6

Be sure to read before handling.

Refer to front matter 53 for Safety Instructions and pages 3 to 8 for 3/4/5 Port Solenoid Valve Precautions.

EX600 Precautions

Wiring

Caution

7. When a reduced wiring system is installed in machinery/equipment, provide adequate protection against noise by using noise filters, etc.
Noise in signal lines may cause malfunction.
8. When connecting wires of input/output device or Handheld Terminal, prevent water, solvent or oil from entering inside from the connector section.
This can cause damage, equipment failure or malfunction.
9. Avoid wiring patterns in which excessive stress is applied to the connector.
This may cause malfunction or damage to the unit due to contact failure.

Operating Environment

Warning

1. Do not use in an atmosphere containing an inflammable gas or explosive gas.
Use in such an atmosphere is likely to cause a fire or explosion. This system is not explosion-proof.

Caution

1. Select the proper type of enclosure according to the environment of operation.
IP65/67 is achieved when the following conditions are met.
 - 1) Provide appropriate wiring between all units using electrical wiring cables, communication connectors and cables with M12 connectors.
 - 2) Suitable mounting of each unit and manifold valve.
 - 3) Be sure to mount a seal cap on any unused connectors.If using in an environment that is exposed to water splashes, please take measures such as using a cover.
When the enclosure is IP40, do not use in an operating environment or atmosphere where it may come in contact with corrosive gas, chemical agents, seawater, water, or water vapor. When connected to EX600-D□□E or EX600-D□□F, manifold enclosure is IP40.
Also, the Handheld Terminal conforms to IP20, so prevent foreign matter from entering inside, and water, solvent or oil from coming in direct contact with it.
2. Provide adequate protection when operating in locations such as the following.
Failure to do so may cause damage or malfunction. The effect of countermeasures should be checked in individual equipment and machine.
 - 1) Where noise is generated by static electricity, etc.
 - 2) Where there is a strong electric field
 - 3) Where there is a danger of exposure to radiation
 - 4) When in close proximity to power supply lines

Operating Environment

Caution

3. Do not use in an environment where oil and chemicals are used.
Operating in environments with coolants, cleaning solvents, various oils or chemicals may cause adverse effects (damage, malfunction) to the unit even in a short period of time.
4. Do not use in an environment where the product could be exposed to corrosive gas or liquid.
This may damage the unit and cause it to malfunction.
5. Do not use in locations with sources of surge generation.
Installation of the unit in an area around the equipment (electromagnetic lifters, high frequency induction furnaces, welding machine, motors, etc.), which generates the large surge voltage could cause to deteriorate an internal circuitry element of the unit or result in damage. Implement countermeasures against the surge from the generating source, and avoid touching the lines with each other.
6. Use the product type that has an integrated surge absorption element when directly driving a load which generates surge voltage by relay, solenoid valves or lamp.
When a surge generating load is directly driven, the unit may be damaged.
7. The product is CE marked, but not immune to lightning strikes. Take measures against lightning strikes in your system.
8. Keep dust, wire scraps and other extraneous material from getting inside the product.
This may cause malfunction or damage.
9. Mount the unit in such locations, where no vibration or shock is affected.
This may cause malfunction or damage.
10. Do not use in places where there are cyclic temperature changes.
In case that the cyclic temperature is beyond normal temperature changes, the internal unit is likely to be adversely affected.
11. Do not use in direct sunlight.
Do not use in direct sunlight. It may cause malfunction or damage.
12. Use this product within the specified ambient temperature range.
This may cause malfunction.
13. Do not use in places where there is radiated heat around it.
Such a place is likely to cause malfunction.



Series SV

Specific Product Precautions 7

Be sure to read before handling.

Refer to front matter 53 for Safety Instructions and pages 3 to 8 for 3/4/5 Port Solenoid Valve Precautions.

EX600 Precautions

Adjustment/Operation

⚠ Warning

1. Do not perform operation or setting with wet hands.
There is a risk of electrical shock.

<Handheld Terminal>

2. Do not apply pressure to the LCD.
There is a possibility of the crack of LCD and injuring.
3. The forced input/output function is used to change the signal status forcibly. When operating this function, be sure to check the safety of the surroundings and installation.
Otherwise, injury or equipment damage could result.
4. Incorrect setting of parameters can cause malfunction. Be sure to check the settings before use.
This may cause injury or equipment damage.

⚠ Caution

1. Use a watchmaker's screwdriver with thin blade for the setting of each switch of the SI Unit.
When setting the switch, do not touch other unrelated parts.
This may cause parts damage or malfunction due to a short circuit.
2. Provide adequate setting for the operating conditions.
Failure to do so could result in malfunction.
Refer to the operation manual for setting of the switches.
3. For the details of programming and address setting, refer to the manual from the PLC manufacturer.
The content of programming related to protocol is designed by the manufacturer of the PLC used.

<Handheld Terminal>

4. Do not press the setting buttons with a sharp pointed object.
This may cause damage or malfunction.
5. Do not apply excessive load and impact to the setting buttons.
This may cause damage, equipment failure or malfunction.

When the order does not include the SI Unit, the Valve Plate to connect the manifold and SI Unit is not mounted. Use attached valve fixing screws and mount the Valve Plate.
(Tightening torque: 0.6 to 0.7 N·m)

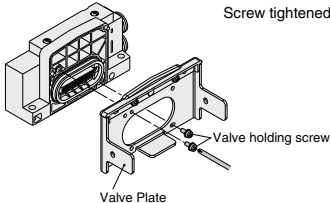

Maintenance

⚠ Warning

1. Do not disassemble, modify (including circuit board replacement) or repair this product.
Such actions are likely to cause injuries or breakage.
2. When an inspection is performed,
 - Turn off the power supply.
 - Stop the air supply, exhaust the residual pressure in piping and verify that the air is released before performing maintenance work.
Unexpected malfunction of system components and injury can result.

⚠ Caution

1. When handling and replacing the unit:
 - Do not touch the sharp metal parts of the connector or plug.
 - Do not apply excessive force to the unit when disassembling.
The connecting portions of the unit are firmly joined with seals.
 - When joining units, take care not to get fingers caught between units.
Injury can result.
2. Perform periodic inspection.
Unexpected malfunction in the system composition devices is likely to occur due to malfunction of machinery or equipment.
3. After maintenance, make sure to perform an appropriate functionality inspection.
In cases of abnormality such as faulty operation, stop operation. Unexpected malfunction in the system composition devices is likely to occur.
4. Do not use benzene and thinner for cleaning units.
Damage to the surface or erasure of the display can result. Wipe off any stains with a soft cloth.
If the stain is persistent, wipe off with a cloth soaked in a dilute solution of neutral detergent and wrung out tightly, and then finish with a dry cloth.

Other

⚠ Caution

1. Refer to the catalog of each series for Common Precautions and Specific Product Precautions on manifold solenoid valves.

■ Trademark

DeviceNet™ is a trademark of ODVA. EtherNet/IP™ is a trademark of ODVA. CompoNet™ is a trademark of ODVA. EtherCAT® is registered trademark and patented technology, licensed by Beckhoff Automation GmbH, Germany.

SJ
SY
SY
SV
SYJ
SZ
VF
VP4
S0700
VQ
VQ4
VQ5
VQC
VQC4
VQZ
SQ
VFS
VFR
VQ7

Fieldbus System (For Input/Output)

New



Compatible Protocols



New Unit type added

Dual port SI Unit (EtherNet/IP™) product

- Can be used for linear type or DLR type topology.
- Supports QuickConnect™ function.
- Status checks and settings can be performed on a web browser.

Reduction in wiring time with SPEEDCON (Phoenix Contact).
Just insert and make 1/2 rotation!

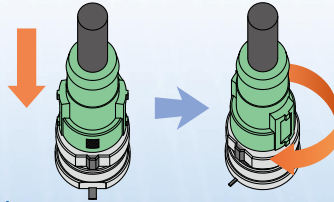

IP67

Note) Some products are IP40.



Handheld Terminal

Self Diagnosis Function

It is possible to ascertain the maintenance period and identify the parts that require maintenance, by an input/output open circuit detection function and an input/output signal ON/OFF counter function. Also, the monitoring of input and output signals and the setting of parameters can be performed with a Handheld Terminal.



Max. 9 Units Note)

Can be connected in any order.

The Input Unit to connect input device such as an auto switch, pressure switch and flow switch, and the Output Unit to connect output device such as a solenoid valve, relay and indicator light can be connected in any order.

Note) Except SI Unit

Manifold Solenoid Valves

Series SY3000/5000/7000



IP67

Series SV1000/2000/3000



IP67

Series S0700



IP40

Series VQC1000/2000/4000



IP67

Note) The SY3000/5000/7000, S0700, and VQC1000/2000/4000 are not UL-compatible.

Series EX600



CAT.E02-24E

Series EX600 Configurations

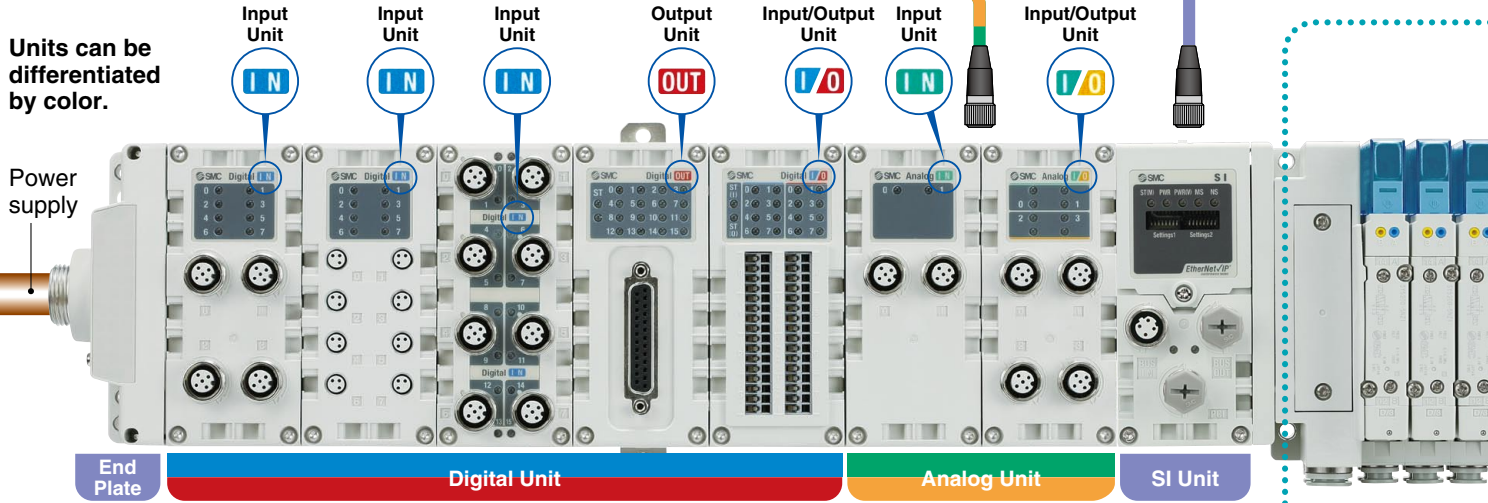
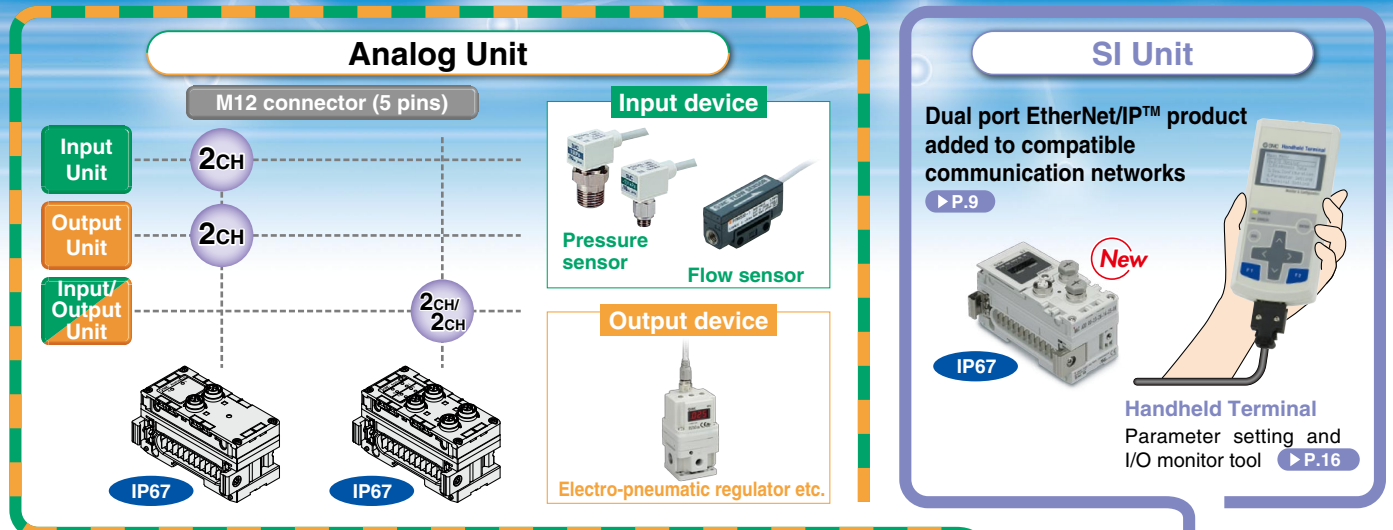

For detailed specifications of connectable device, refer to the catalog of each device and select the right device for your application. If anything is unclear, please contact SMC.

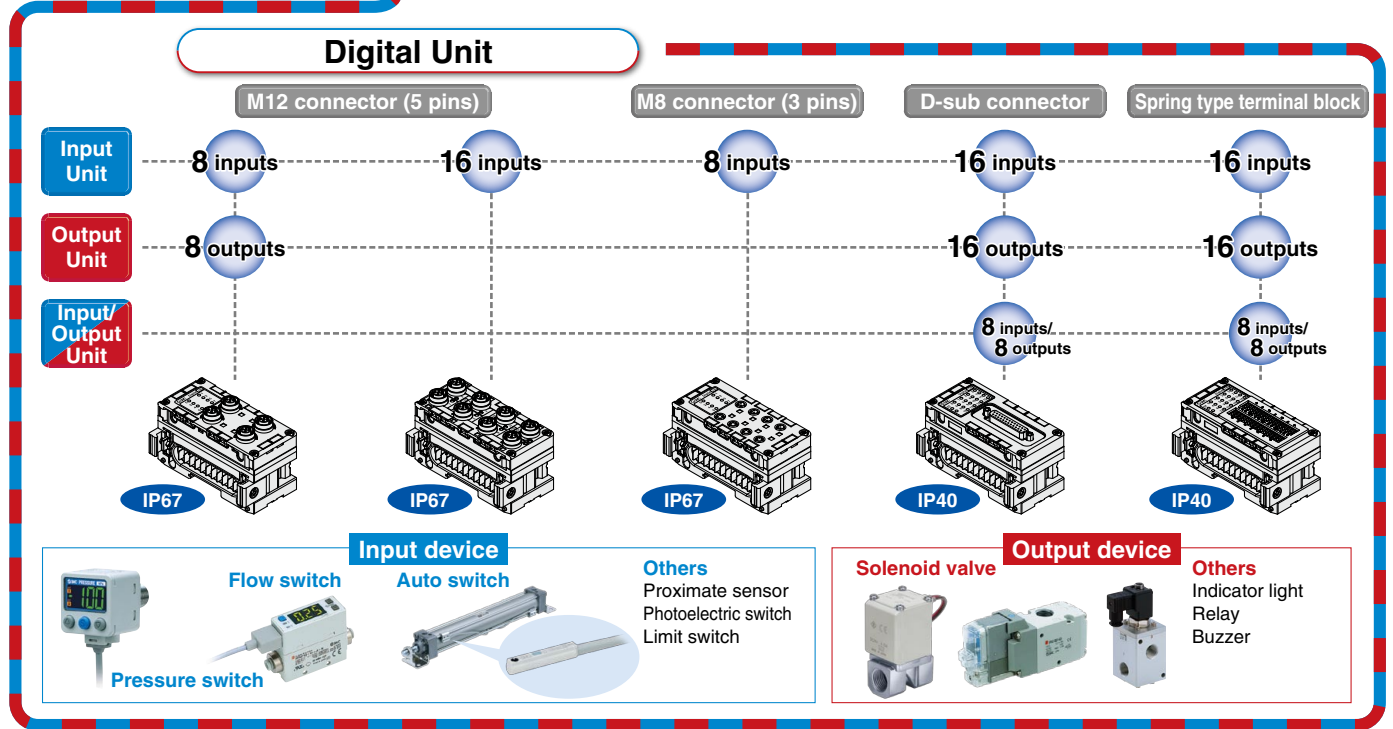



Manifold solenoid valves



Series SY (IP67)



▶ P.27



Series SV (IP67)

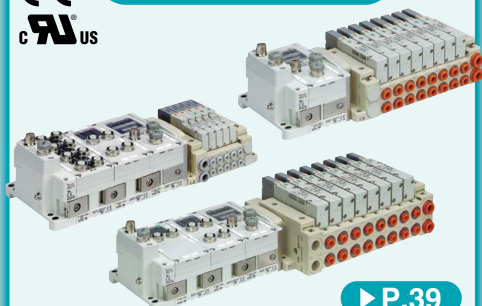

▶ P.39



Series S0700 (IP40)



▶ P.47



Series VQC (IP67)



▶ P.51

SI Unit

Unit to connect various Fieldbus with the EX600 system

- How to Order ▶ P. 9
- Specifications ▶ P. 11, 12
- Parts Description ▶ P. 17
- Dimensions ▶ P. 19



Digital Unit

Unit to input or output digital (switch) signals

- How to Order ▶ P. 9
- Specifications ▶ P. 13, 14
- Parts Description ▶ P. 18
- Dimensions ▶ P. 20



Analog Unit

Unit to input or output analog (voltage/current) signals

- How to Order ▶ P. 10
- Specifications ▶ P. 15, 16
- Parts Description ▶ P. 18
- Dimensions ▶ P. 20



End Plate

Unit to supply power to the EX600 system

- How to Order ▶ P. 10
- Specifications ▶ P. 16
- Parts Description ▶ P. 18
- Dimensions ▶ P. 19



Handheld Terminal

Parameter setting and I/O monitor tool

- How to Order ▶ P. 10
- Specifications ▶ P. 16
- Parts Description ▶ P. 17
- Dimensions ▶ P. 19



Accessories

Options including a power supply cable etc. for the EX600 series



▶ P. 21

Table of Mountable Units ▶ P. 25

Manifold Solenoid Valves for EX600..... ▶ P. 26

Specific Product Precautions ▶ P. 63

Latest EtherNet/IP™ Technology

The following functions are available for the dual port EtherNet/IP™ product (EX600-SEN3/4).

Added Compatible Topologies (connection configuration).

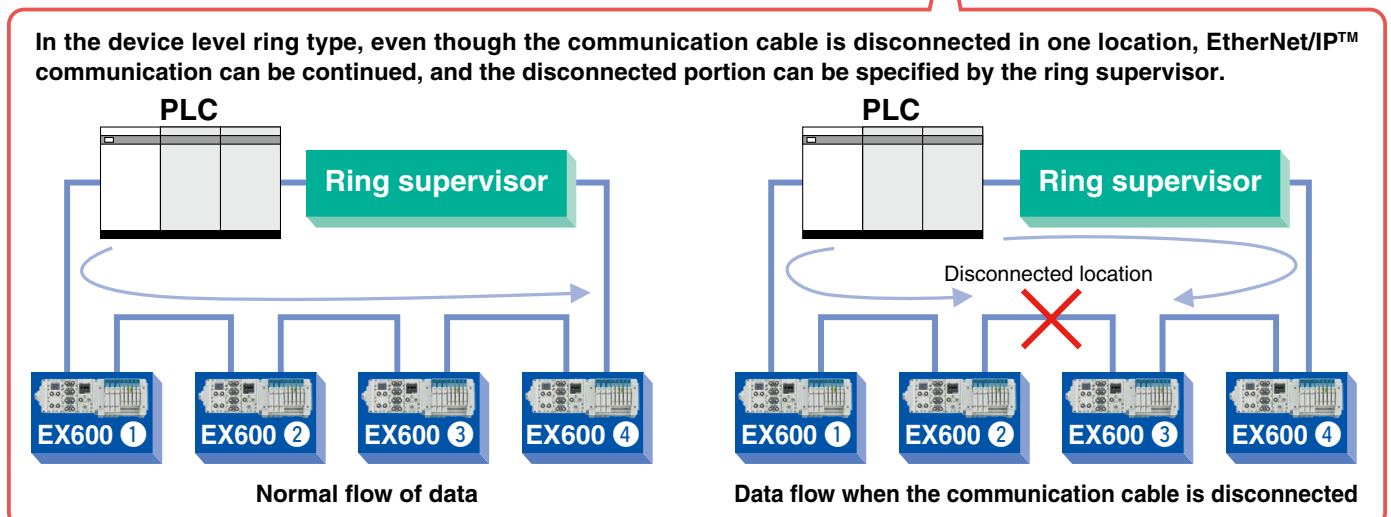
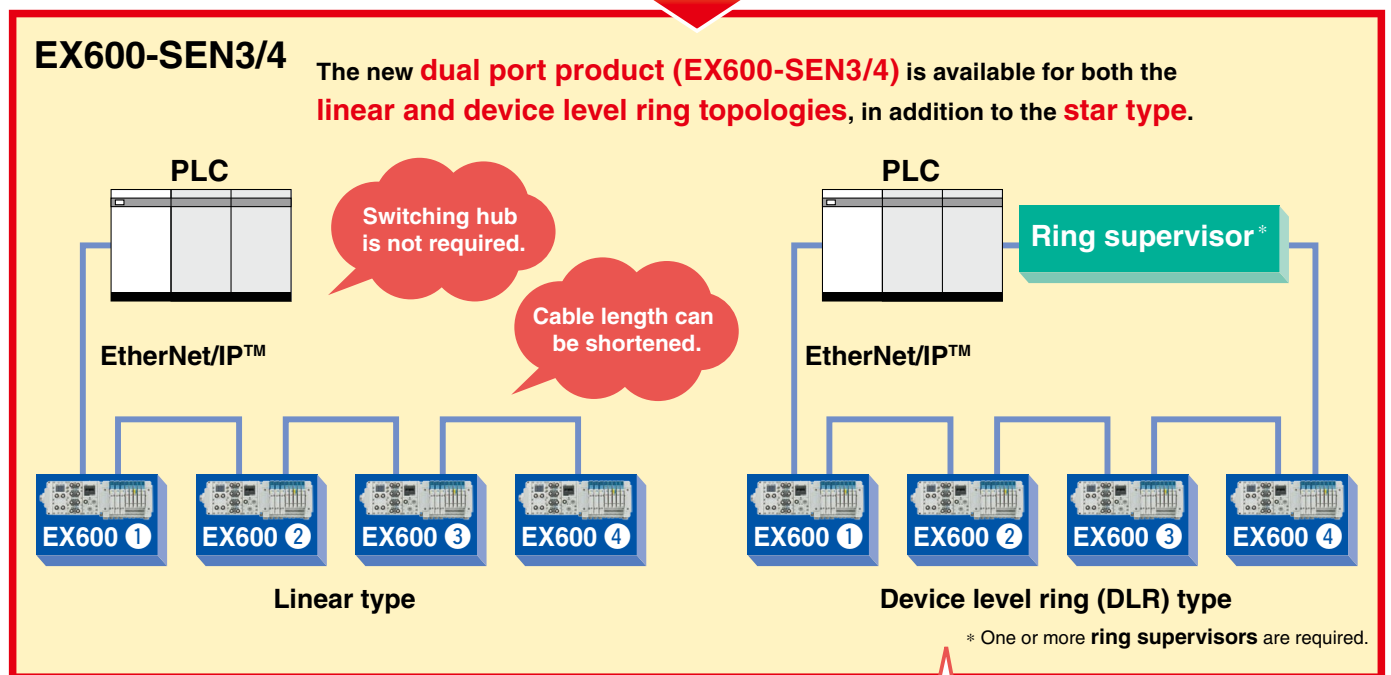
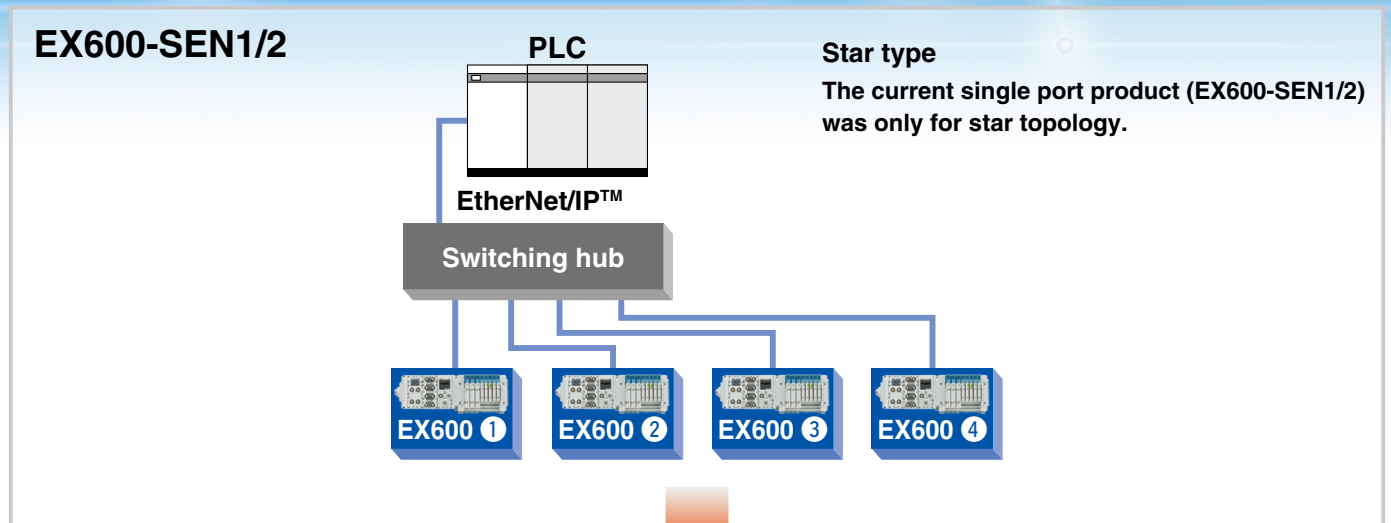

QuickConnect™ Function Available

From Power ON to communication connection

10 sec.

Approx. **0.5 sec.**

In the case of a tool changer, it takes about 10 seconds for the communication to be connected in common EtherNet/IP™ products, after the power of the device installed on the tool is turned ON. Since the QuickConnect™ function* is available in the EX600-SEN3/4, the communication can be connected in about 0.5 seconds.

Greatly reduces the communication connection time to the EtherNet/IP™.

* To use the QuickConnect™ function, the PLC should be able to support the QuickConnect™ function.

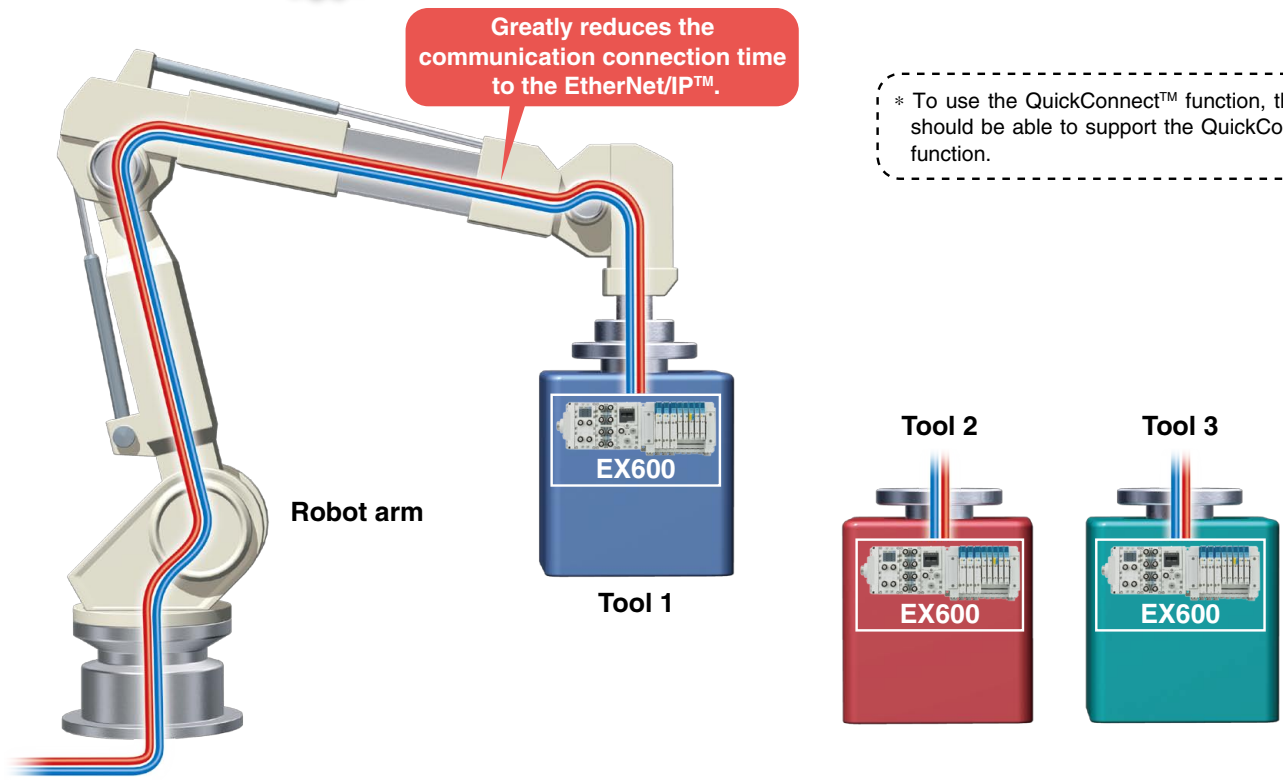

Built-in Web Server Function

The EX600-SEN3/4 has a built-in web server function, which enables status checks, parameter settings and forced output of the EX600 using general-purpose web browsers, such as Internet Explorer. Start-up of the system and maintenance can be performed efficiently.

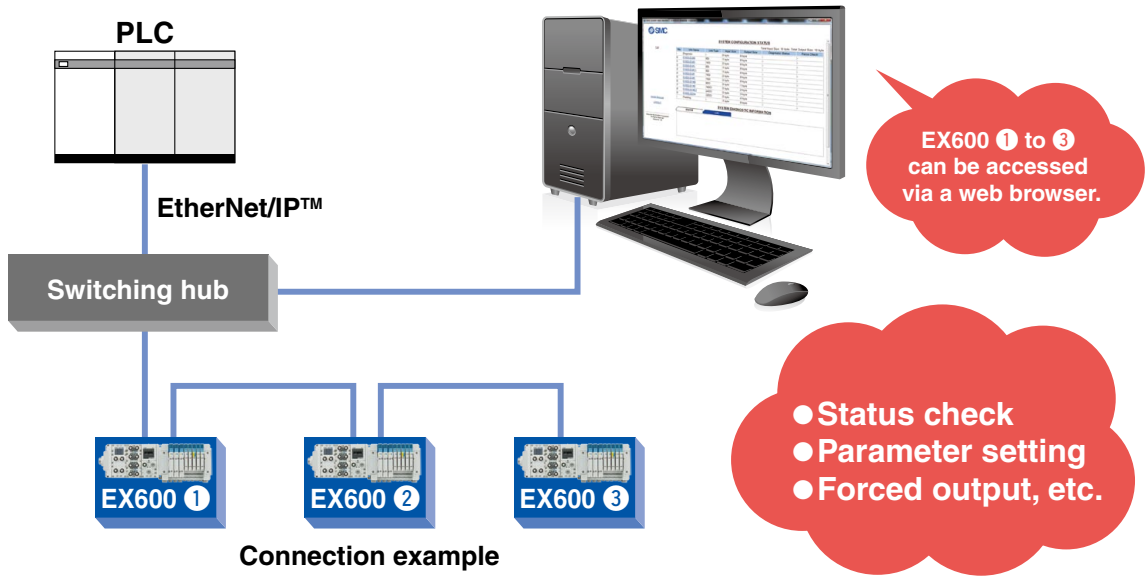

Connection example

Fieldbus System EX600

D-sub Connector

IP40

These Units are capable of connection using a D-sub connector. There are three types of Units, for Digital Input, Output, and Input/Output. The Digital Output Unit can be connected with an SMC manifold solenoid valve F kit (D-sub connector).

Manifold solenoid valve can be connected using cable with D-sub connector.

- Series SY • Series S0700 • Series SJ • Series SQ
- Series SV • Series VQC • Series VQ

* Please limit the number of valve connections to 16 stations for single and 8 stations for double. Refer to the catalog for each product for pin assignment details.

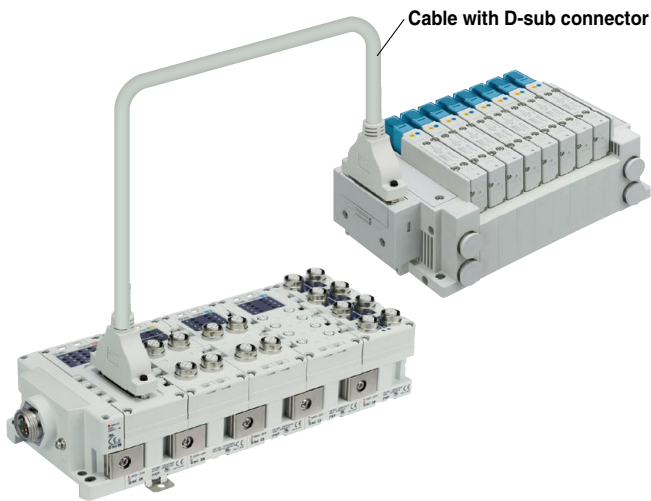

Spring Type Terminal Block

IP40

These Terminal Block Units are compatible with individual wiring configurations. There are three types of Units, for Digital Input, Output, and Input/Output. Wiring connection to a sensor connector box, etc., can be carried out easily using only a flat head screwdriver.

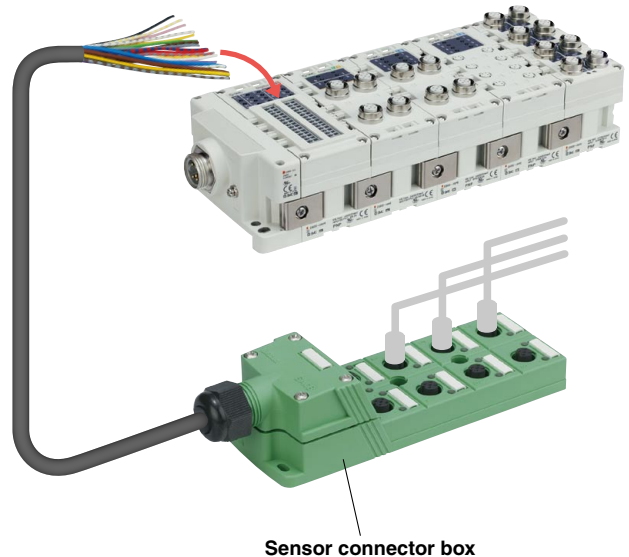

Digital Input Unit

IP67

This Unit is for inputting a digital signal (ON/OFF signal). The signal of a 2-wire/3-wire auto switch attached to the actuator can be acquired to feedback a signal to the PLC. The control signal of an entire system can be managed by Fieldbus System.

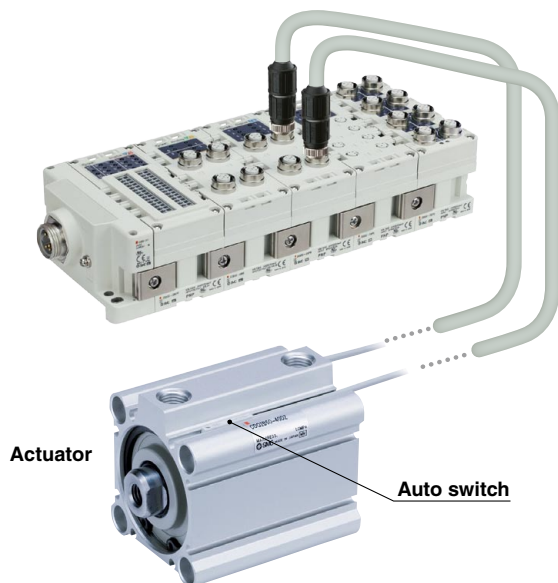

Analog Input/Output Unit

IP67

These Units are for inputting or outputting an analog signal (voltage/ current). A single Unit performs both input and output, allowing feedback control where analog signals are received from a pressure sensor and sent to a pressure controller. Installation space is minimized as well.

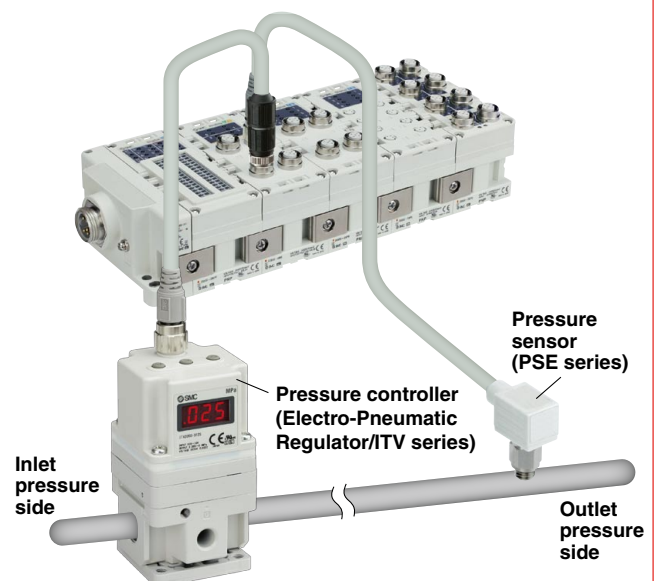

Self Diagnosis Function

In combination with the Handheld Terminal, the following two functions are available.

Short/Open Circuit Detection Function

It is possible to detect short or open circuit of input device such as an electronic 2-wire switch and 3-wire switch and output device such as a solenoid valve. The location of the error can be identified by the indicator light and the network.



Green ON Normal

Red ON Short circuit

Red flashing Open circuit

Counter Function

It is possible to ascertain the maintenance period and identify the parts that require maintenance by an input and output signal ON/OFF counter function. When the counter function is enabled and a certain number of contact operations is reached, the display of counter will flash in red.

Note) The counter function is not provided with the Analog Unit.

Handheld Terminal

Forced Input and Output Function

The input and output signals are controlled forcibly without a PLC. The startup time after facility introduction can be shortened.

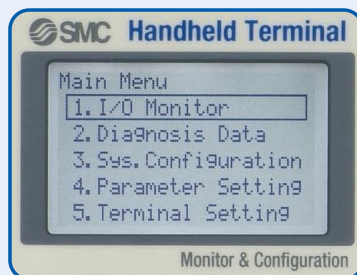

Password Setting Function

Simple Operation

Cursor button: **Mode and setting change** etc.

Function key: **Value and command entry** etc.

Can be used for the adjustment of internal parameters and the monitoring of input and output signal status.

Parameters: **Analog data format**
Analog measurement range
Input filter selection
Counter function
Open circuit detection function, etc.

A parameter is a set value to change the function and operation of the product through a PLC or Handheld Terminal. The desired operation for the customer's application is realized by the set values. There are some parameters that can only be set using the Handheld Terminal of this series.

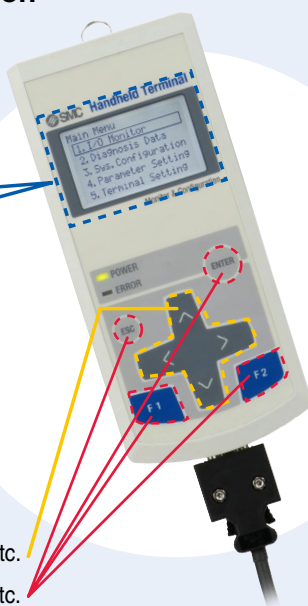

Fieldbus System EX600

● Individual Units can be connected and removed one by one.

A unique clamping method is adopted to prevent screws from falling out. It is easy to separate the Unit just by loosening joint bracket.

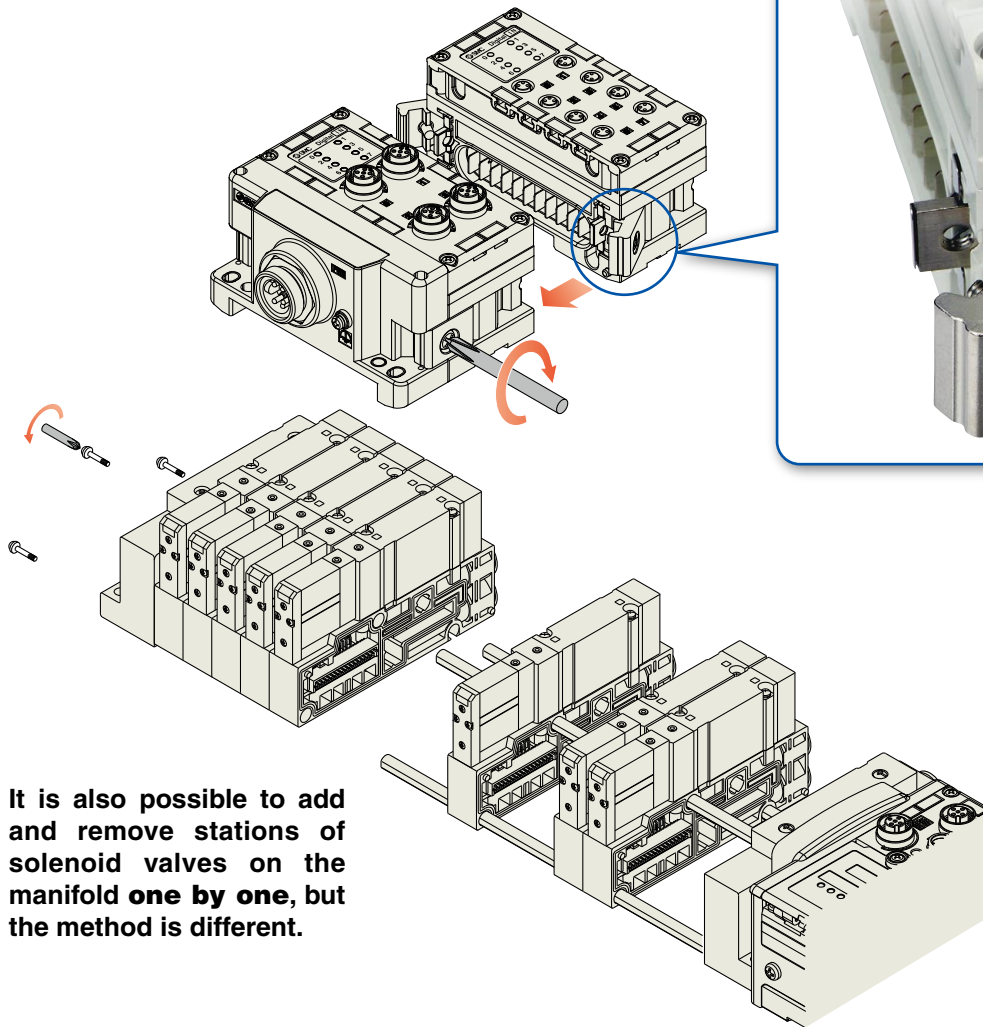

It is also possible to add and remove stations of solenoid valves on the manifold **one by one**, but the method is different.

5 Port Solenoid Valves SY3000/5000/7000

● Different sizes (SY3000/5000 or SY5000/7000) can be mixed!

The installation area can be reduced, and the number of SI Units and the wiring can also be reduced.

Overall length of manifold
Approx. 22% reduction

Example of SY3000 and SY5000

Installation space

Single manifold
SY5000 3 stations

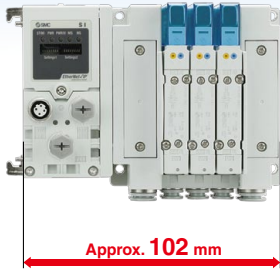

Approx. 102 mm

Single manifold
SY3000 5 stations



Approx. 117 mm

Mixed manifold

SY5000 3 stations SY3000 5 stations



Approx. 170 mm

Number of SI Units, Unit cost

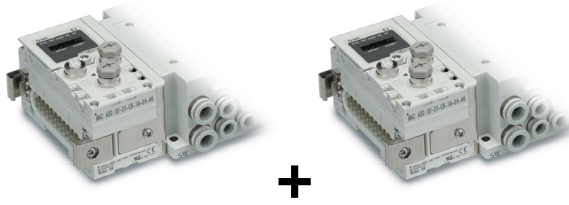

Manifold 2 pcs.
Serial Units 2 sets



Manifold 1 pc.
Serial Unit 1 set

● Bottom ported type is available!

Top or bottom ported reduces the footprint.

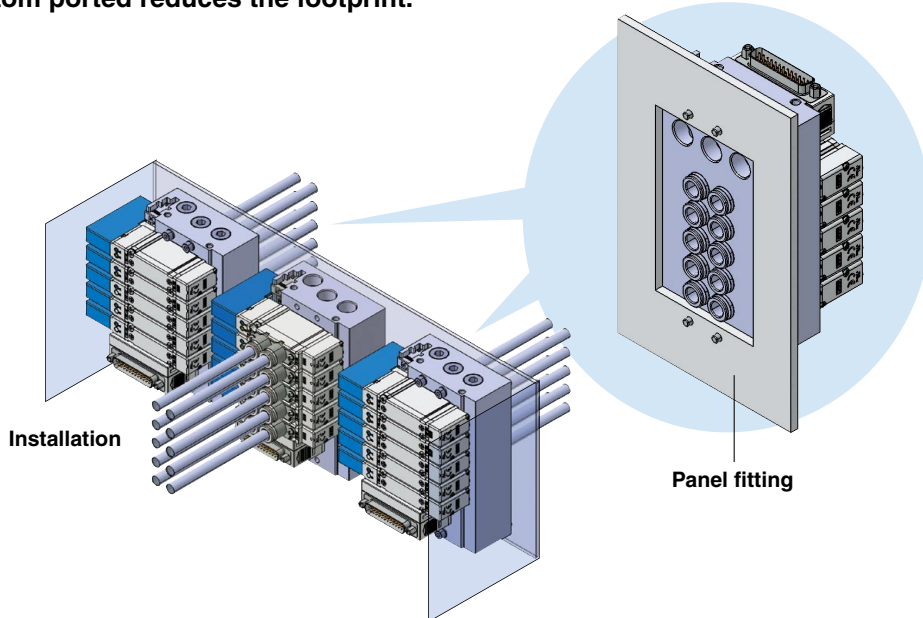

Series EX600

Series SY

Series SV

Series S0700

Series VQC

Fieldbus System

Series EX600



How to Order

SI Unit

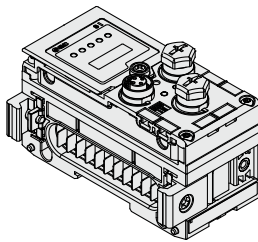

EX600-S EN 3

Protocol

Symbol	Description
PR	PROFIBUS DP
DN	DeviceNet™
MJ	CC-Link
EN	EtherNet/IP™ Note 1)
EC	EtherCAT® Note 1)
PN	PROFINET Note 1)

Version

Symbol	Condition
Nil	Select in the case of MJ, EN, EC or PN.
A	Select in the case of PR or DN.

Output type

Symbol	Description	Condition
1	PNP (Negative common)	Can be selected by all protocols.
2	NPN (Positive common)	Can be selected by all protocols.
3	PNP (Negative common) EtherNet/IP (2 ports)	Can be selected in the case of EN.
4	NPN (Positive common) EtherNet/IP (2 ports)	Can be selected in the case of EN.

Digital Input Unit

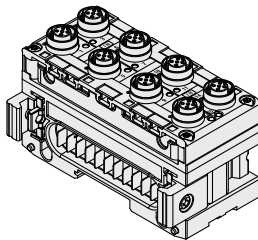

EX600-DX P D

Input type

Symbol	Description
P	PNP
N	NPN

Number of Inputs, Open circuit detection, and Connector

Symbol	Number of inputs	Open circuit detection	Connector
B	8 inputs	No	M12 connector (5 pins) 4 pcs.
C	8 inputs	No	M8 connector (3 pins) 8 pcs.
C1	8 inputs	Yes	M8 connector (3 pins) 8 pcs.
D	16 inputs	No	M12 connector (5 pins) 8 pcs.
E	16 inputs	No	D-sub connector (25 pins) Note 1) 2)
F	16 inputs	No	Spring type terminal block (32 pins) Note 1) 2)

Digital Output Unit

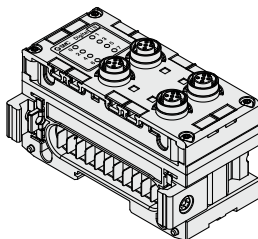

EX600-DY P B

Output type

Symbol	Description
P	PNP
N	NPN

Number of Outputs and Connector

Symbol	Number of outputs	Connector
B	8 outputs	M12 connector (5 pins) 4 pcs.
E	16 outputs	D-sub connector (25 pins) Note 1) 2)
F	16 outputs	Spring type terminal block (32 pins) Note 1) 2)

Digital Input/Output Unit

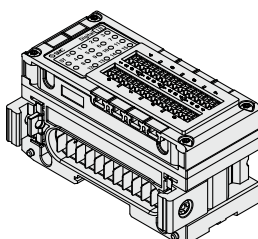

EX600-DM P F

Input/Output type

Symbol	Description
P	PNP
N	NPN

Number of Inputs/Outputs and Connector

Symbol	Number of inputs	Number of outputs	Connector
E	8 inputs	8 outputs	D-sub connector (25 pins) Note 1) 2)
F	8 inputs	8 outputs	Spring type terminal block (32 pins) Note 1) 2)

Note 1) Cannot be communicated with the EX600-HT1-□. Refer to page 25 for "Table of Mountable Units."

Note 2) Cannot be connected with the EX600-SPR1, EX600-SPR2, EX600-SDN1, or EX600-SDN2. Refer to page 25 for "Table of Mountable Units."

How to Order

Analog Input Unit

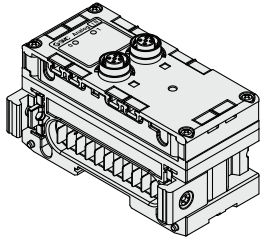

EX600-AXA

Analog input

Number of Input channels and Connector

Symbol	Number of input channels	Connector
A	2 channels	M12 connector (5 pins) 2 pcs.

Series EX600

Series SY

Series SV

Series S0700

Series VQC

Analog Output Unit

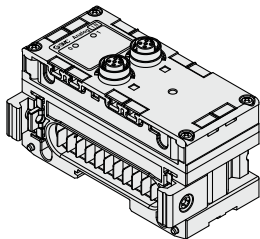

EX600-AYA

Analog output

Number of Output channels and Connector

Symbol	Number of output channels	Connector
A	2 channels	M12 connector (5 pins) 2 pcs. <small>Note1) 2)</small>

Analog Input/Output Unit

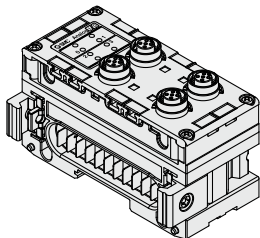

EX600-AMB

Analog input/output

Number of Input/Output channels and Connector

Symbol	Number of input channels	Number of output channels	Connector
B	2 channels	2 channels	M12 connector (5 pins) 4 pcs. <small>Note1) 2)</small>

End Plate

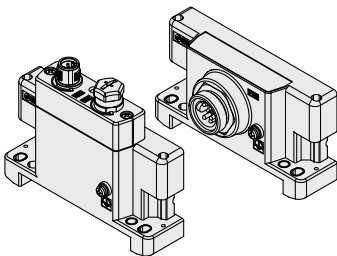

EX600-ED2

Power connector

Mounting method

Symbol	Connector
2	M12 (5 pins)
3	7/8 inch (5 pins)

Symbol	Description
Nil	Without DIN rail mounting bracket
2	With DIN rail mounting bracket
3	With DIN rail mounting bracket (Specialized for SY series)

Handheld Terminal

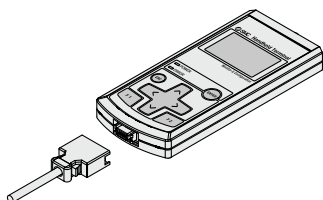

EX600-HT1A-3

Version

Cable length

Symbol	Description
Nil	No cable
1	1 m
3	3 m

Handheld Terminals are not yet UL-compatible.

Note 1) Cannot be communicated with the EX600-HT1-□. Refer to page 25 for "Table of Mountable Units."

Note 2) Cannot be connected with the EX600-SPR1, EX600-SPR2, EX600-SDN1, or EX600-SDN2. Refer to page 25 for "Table of Mountable Units."

Series EX600

SI Unit Specifications

All Units Common Specifications

Environmental resistance	Operating temperature range	-10 to 50°C
	Storage temperature range	-20 to 60°C
	Operating humidity range	35 to 85% RH (No dew condensation)
	Withstand voltage ^{Note)}	500 VAC for 1 minute between external terminals and FE
	Insulation resistance ^{Note)}	500 VDC, 10 MΩ or more between external terminals and FE

Note) Except Handheld Terminals

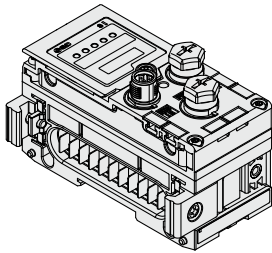

EX600-SPR□A

SI Unit (EX600-SPR□A)

Model		EX600-SPR1A	EX600-SPR2A
Communication	Protocol	PROFIBUS DP (DP-V0)	
	Device type	PROFIBUS DP Slave	
	Communication speed	9.6/19.2/45.45/93.75/187.5/500 kbps 1.5/3/6/12 Mbps	
	Configuration file	GSD file	
	Occupation area (Number of inputs/outputs)	Max. (512 inputs/512 outputs)	
Terminating resistor		Internally implemented	
Internal current consumption (Power supply for Control/Input)		80 mA or less	
Output	Output type	Source/PNP (Negative common)	Sink/NPN (Positive common)
	Number of outputs	32 outputs (8/16/24/32 outputs selectable)	
	Load	Solenoid valve with surge voltage suppressor 24 VDC, 1.5 W or less (SMC)	
	Power supply	24 VDC, 2 A	
	Fail safe	HOLD/CLEAR/Forced power ON	
Protection		Short-circuit protection	
Enclosure		IP67 (Manifold assembly)	
Standards		CE Marking, UL (CSA), RoHS compliant	
Weight		300 g	

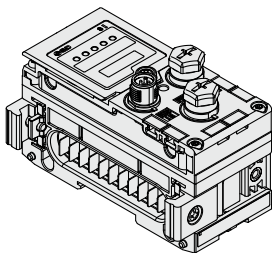

EX600-SDN□A

SI Unit (EX600-SDN□A)

Model		EX600-SDN1A	EX600-SDN2A
Communication	Protocol	DeviceNet™: Volume 1 (Edition 2.1), Volume 3 (Edition 1.1)	
	Device type	Group 2 Only Server	
	Communication speed	125/250/500 kbps	
	Configuration file	EDS file	
	Occupation area (Number of inputs/outputs)	Max. (512 inputs/512 outputs)	
Applicable messages		Duplicate MAC ID Check Message Group 2 Only Unconnected Explicit Message Explicit Message (Group 2) Poll I/O Message (Predefined M/S Connection set)	
DeviceNet™ power supply		11 to 25 VDC (Current consumption 50 mA or less)	
Internal current consumption (Power supply for Control/Input)		55 mA or less	
Output	Output type	Source/PNP (Negative common)	Sink/NPN (Positive common)
	Number of outputs	32 outputs (8/16/24/32 outputs selectable)	
	Load	Solenoid valve with surge voltage suppressor 24 VDC, 1.5 W or less (SMC)	
	Power supply	24 VDC, 2 A	
	Fail safe	HOLD/CLEAR/Forced power ON	
Protection		Short-circuit protection	
Enclosure		IP67 (Manifold assembly)	
Standards		CE Marking, UL (CSA), RoHS compliant	
Weight		300 g	

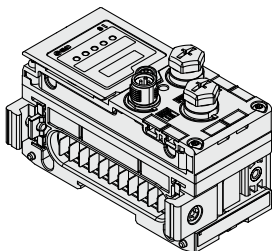

EX600-SMJ□

SI Unit (EX600-SMJ□)

Model		EX600-SMJ1	EX600-SMJ2
Communication	Protocol	CC-Link (Ver. 1.10, Ver. 2.00)	
	Station type	Remote Device Station	
	Communication speed	156/625 kbps 2.5/5/10 Mbps	
	Occupation area (Number of inputs/outputs)	Max. (512 inputs/512 outputs) 1/2/3/4 stations occupied	
	Internal current consumption (Power supply for Control/Input)		75 mA or less
Output	Output type	Source/PNP (Negative common)	Sink/NPN (Positive common)
	Number of outputs	32 outputs (8/16/24/32 outputs selectable)	
	Load	Solenoid valve with surge voltage suppressor 24 VDC, 1.5 W or less (SMC)	
	Power supply	24 VDC, 2 A	
	Fail safe	HOLD/CLEAR/Forced power ON	
Protection		Short-circuit protection	
Enclosure		IP67 (Manifold assembly)	
Standards		CE Marking, UL (CSA), RoHS compliant	
Weight		300 g	

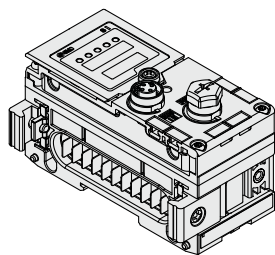

EX600-SEN1/2

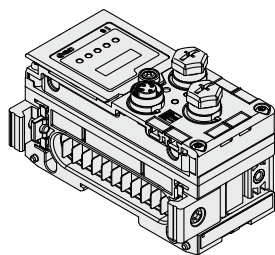

EX600-SEN3/4

SI Unit (EX600-SEN□)

Model		EX600-SEN1	EX600-SEN2	EX600-SEN3	EX600-SEN4
Communication	Number of communication ports	1 port		2 ports	
	Protocol	EtherNet/IP™ (Conformance version: Composite 6)		EtherNet/IP™ (Conformance version: Composite 11)	
	Communication speed	10/100 Mbps			
	Communication method	Full duplex/Half duplex			
	Configuration file	EDS file			
	Occupation area (Number of inputs/outputs)	Max. (512 inputs/512 outputs)			
	IP address setting range	SI Unit switch settings: 192.168.0 or 1.1 to 254 Through DHCP server: Optional address			
	Device information	Vendor ID: 7 (SMC Corporation) Device type: 12 (Communication Adapter) Product code: 126		Vendor ID: 7 (SMC Corporation) Device type: 12 (Communication Adapter) Product code: 203	
	QuickConnect™	—		Compliant	
	DLR	—		Compliant	
WEB server	—		Compliant		
Internal current consumption		120 mA or less			
Output	Output type	Source/PNP (Negative common)	Sink/NPN (Positive common)	Source/PNP (Negative common)	Sink/NPN (Positive common)
	Number of outputs	32 outputs (8/16/24/32 outputs selectable)		32 outputs	
	Load	Solenoid valve with surge voltage suppressor 24 VDC, 1.5 W or less (SMC)		Solenoid valve with surge voltage suppressor 24 VDC, 1.0 W or less (SMC)	
	Power supply	24 VDC, 2 A			
	Fail safe	HOLD/CLEAR/Forced power ON			
	Protection	Short-circuit protection			
	Enclosure	IP67 (Manifold assembly)			
Standards	CE Marking, UL (CSA), RoHS compliant				
Weight	300 g				

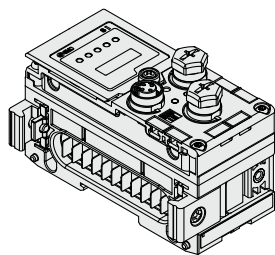

EX600-SEC□

SI Unit (EX600-SEC□)

Model		EX600-SEC1	EX600-SEC2
Communication	Protocol	EtherCAT® (Conformance Test Record V.1.2)	
	Communication speed	100 Mbps	
	Configuration file	XML file	
	Occupation area (Number of inputs/outputs)	Max. (512 inputs/512 outputs)	
Internal current consumption (Power supply for Control/Input)		100 mA or less	
Output	Output type	Source/PNP (Negative common)	Sink/NPN (Positive common)
	Number of outputs	32 outputs (8/16/24/32 outputs selectable)	
	Load	Solenoid valve with surge voltage suppressor 24 VDC, 1.5 W or less (SMC)	
	Power supply	24 VDC, 2 A	
	Fail safe	HOLD/CLEAR/Forced power ON	
Protection	Short-circuit protection		
Enclosure	IP67 (Manifold assembly)		
Standards	CE Marking, UL (CSA), RoHS compliant		
Weight	300 g		

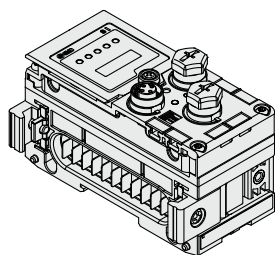

EX600-SPN□

SI Unit (EX600-SPN□)

Model		EX600-SPN1	EX600-SPN2
Communication	Protocol	PROFINET IO (PROFINET RT)	
	Communication speed	100 Mbps	
	Configuration file	GSDML file	
	Occupation area (Number of inputs/outputs)	Max. (512 inputs/512 outputs)	
Internal current consumption (Power supply for Control/Input)		120 mA or less	
Output	Output type	Source/PNP (Negative common)	Sink/NPN (Positive common)
	Number of outputs	32 outputs	
	Load	Solenoid valve with surge voltage suppressor 24 VDC, 1.0 W or less (SMC)	
	Power supply	24 VDC, 2 A	
	Fail safe	HOLD/CLEAR/Forced power ON	
Protection	Short-circuit protection		
Enclosure	IP67 (Manifold assembly)		
Standards	CE Marking, UL (CSA), RoHS compliant		
Weight	300 g		

Series EX600

Digital Unit Specifications

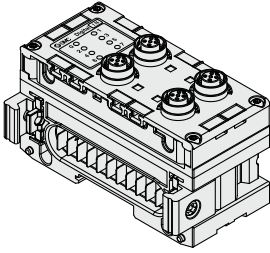

EX600-DX□B

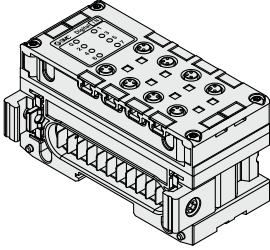

EX600-DX□C

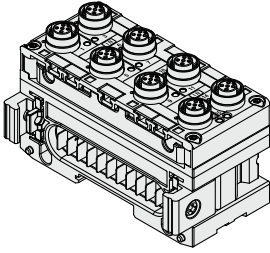

EX600-DX□D

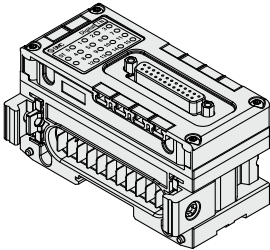

EX600-DX□E

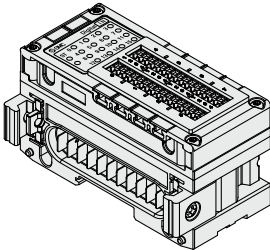

EX600-DX□F

Digital Input Unit

Model		EX600-DXPB	EX600-DXNB	EX600-DXPC□	EX600-DXNC□	EX600-DXPD	EX600-DXND
Input	Input type	PNP	NPN	PNP	NPN	PNP	NPN
	Input connector	M12 (5-pin) socket ^{Note 1)}		M8 (3-pin) socket ^{Note 3)}		M12 (5-pin) socket ^{Note 1)}	
	Number of inputs	8 inputs (2 inputs/Connector)		8 inputs (1 input/Connector)		16 inputs (2 inputs/Connector)	
	Supplied voltage	24 VDC					
	Max. supplied current	0.5 A/Connector 2 A/Unit		0.25 A/Connector 2 A/Unit		0.5 A/Connector 2 A/Unit	
	Protection	Short-circuit protection					
	Input current (at 24 VDC)	9 mA or less					
	ON voltage	17 V or more (At NPN input, between the pin for input terminal and supplied voltage of +24 V) (At PNP input, between the pin for input terminal and supplied voltage of 0 V)					
	OFF voltage	5 V or less (At NPN input, between the pin for input terminal and supplied voltage of +24 V) (At PNP input, between the pin for input terminal and supplied voltage of 0 V)					
	Open circuit detection current	2 wires	—		0.5 mA/Input ^{Note 2)}		—
3 wires		—		0.5 mA/Connector ^{Note 2)}		—	
Current consumption	50 mA or less		55 mA or less		70 mA or less		
Enclosure	IP67 (Manifold assembly)						
Standards	CE Marking, UL (CSA), RoHS compliant						
Weight	300 g		275 g		340 g		

Note 1) M12 (4-pin) connector can be connected.

Note 2) Function only applies to the EX600-DX□C1.

Note 3) When connecting the M8 plug connector, the tightening torque must be 0.2 N·m ±10%. If tightened with an excessive tightening torque, this may cause the connector thread of the Unit to break.

Model		EX600-DXPE	EX600-DXNE	EX600-DXPF	EX600-DXNF	
Input	Input type	PNP	NPN	PNP	NPN	
	Input connector	D-sub socket (25 pins) Lock screw: No.4-40 UNC		Spring type terminal block (32 pins)		
	Number of inputs	16 inputs		16 inputs (2 inputs x 8 blocks)		
	Supplied voltage	24 VDC				
	Max. supplied current	2 A/Unit		0.5 A/Block 2 A/Unit		
	Protection	Short-circuit protection				
	Input current (at 24 VDC)	5 mA or less				
	ON voltage	17 V or more (At NPN input, between the pin for input terminal and supplied voltage of +24 V) (At PNP input, between the pin for input terminal and supplied voltage of 0 V)				
	OFF voltage	5 V or less (At NPN input, between the pin for input terminal and supplied voltage of +24 V) (At PNP input, between the pin for input terminal and supplied voltage of 0 V)				
	Applicable wire	—		0.08 to 1.5 mm ² (AWG16 to 28)		
Current consumption	50 mA or less		55 mA or less			
Enclosure	IP40 (Manifold assembly)					
Standards	CE Marking, UL (CSA), RoHS compliant					
Weight	300 g					

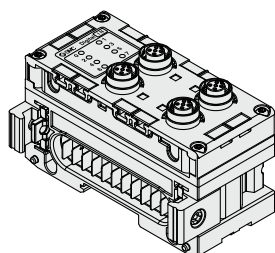

EX600-DY□B

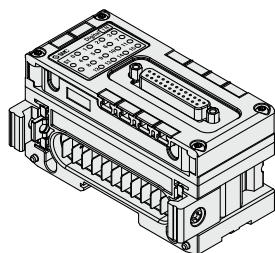
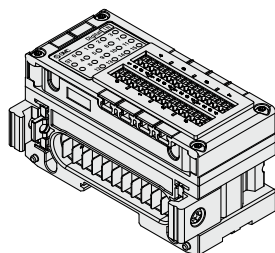
 EX600-DY□E
EX600-DM□E

 EX600-DY□F
EX600-DM□F

Digital Output Unit

Model	EX600-DYPB	EX600-DYNB	EX600-DYPE	EX600-DYNE	EX600-DYPF	EX600-DYNF
Output type	PNP	NPN	PNP	NPN	PNP	NPN
Output connector	M12 (5-pin) socket <small>Note</small>		D-sub socket (25 pins) Lock screw: No.4-40 UNC		Spring type terminal block (32 pins)	
Number of outputs	8 outputs (2 outputs/Connector)		16 outputs		16 outputs (2 outputs x 8 blocks)	
Supplied voltage	24 VDC					
Max. load current	0.5 A/Output 2 A/Unit					
Protection	Short-circuit protection					
Applicable wire	—		—		0.08 to 1.5 mm ² (AWG16 to 28)	
Current consumption	50 mA or less					
Enclosure	IP67 (Manifold assembly)			IP40 (Manifold assembly)		
Standards	CE Marking, UL (CSA), RoHS compliant					
Weight	300 g					

Note) M12 (4-pin) connector can be connected.

Digital Input/Output Unit

Model	EX600-DMPE	EX600-DMNE	EX600-DMPF	EX600-DMNF
Input/Output type	PNP	NPN	PNP	NPN
Connector	D-sub socket (25 pins) Lock screw: No.4-40 UNC		Spring type terminal block (32 pins)	
Number of inputs	8 inputs		8 inputs (2 inputs x 4 blocks)	
Supplied voltage	24 VDC			
Max. supplied current	2 A/Unit		0.5 A/Block 2 A/Unit	
Protection	Short-circuit protection			
Input current (at 24 VDC)	5 mA or less			
ON voltage	17 V or more (At NPN input, between the pin for input terminal and supplied voltage of +24 V) (At PNP input, between the pin for input terminal and supplied voltage of 0 V)			
OFF voltage	5 V or less (At NPN input, between the pin for input terminal and supplied voltage of +24 V) (At PNP input, between the pin for input terminal and supplied voltage of 0 V)			
Number of outputs	8 outputs		8 outputs (2 outputs x 4 blocks)	
Supplied voltage	24 VDC			
Max. load current	0.5 A/Output 2 A/Unit			
Protection	Short-circuit protection			
Applicable wire	—		0.08 to 1.5 mm ² (AWG16 to 28)	
Current consumption	50 mA or less		60 mA or less	
Enclosure	IP40 (Manifold assembly)			
Standards	CE Marking, UL (CSA), RoHS compliant			
Weight	300 g			

Series EX600

Analog Unit Specifications

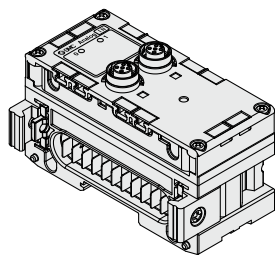

EX600-AXA

Analog Input Unit

Model		EX600-AXA		
Input	Input type	Voltage input	Current input	
	Input connector	M12 (5-pin) socket ^{Note 1)}		
	Input channel	2 channels (1 channel/Connector)		
	Supplied voltage	24 VDC		
	Max. supplied current	0.5 A/Connector		
	Protection	Short-circuit protection		
	Input signal range	12 bit resolution	0 to 10 V, 1 to 5 V, 0 to 5 V	0 to 20 mA, 4 to 20 mA
		16 bit resolution	-10 to 10 V, -5 to 5 V	-20 to 20 mA
	Max. rated input signal	±15 V	±22 mA ^{Note 2)}	
	Input impedance	100 kΩ	50 Ω	
	Linearity (25°C)	±0.05% F.S.		
	Repeatability (25°C)	±0.15% F.S.		
	Absolute accuracy (25°C)	±0.5% F.S.	±0.6% F.S.	
	Current consumption	70 mA or less		
Enclosure	IP67 (Manifold assembly)			
Standards	CE Marking, UL (CSA), RoHS compliant			
Weight	290 g			

Note 1) M12 (4-pin) connector can be connected.

Note 2) When input signal exceeds 22 mA, the protection function activates and the input signal is interrupted.

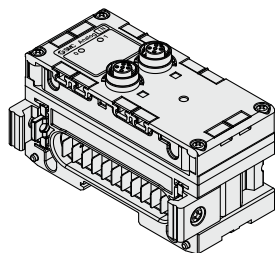

EX600-AYA

Analog Output Unit

Model		EX600-AYA		
Output	Output type	Voltage output	Current output	
	Output connector	M12 (5-pin) socket ^{Note)}		
	Output channel	2 channels (1 channel/Connector)		
	Supplied voltage	24 VDC		
	Max. load current	0.5 A/Connector		
	Protection	Short-circuit protection		
	Output signal range	12 bit resolution	0 to 10 V, 1 to 5 V, 0 to 5 V	0 to 20 mA, 4 to 20 mA
		16 bit resolution	-10 to 10 V, -5 to 5 V	-20 to 20 mA
	Load impedance	1 kΩ or more	600 Ω or less	
	Linearity (25°C)	±0.05% F.S.		
	Repeatability (25°C)	±0.15% F.S.		
	Absolute accuracy (25°C)	±0.5% F.S.	±0.6% F.S.	
	Current consumption	70 mA or less		
	Enclosure	IP67 (Manifold assembly)		
Standards	CE Marking, UL (CSA), RoHS compliant			
Weight	290 g			

Note) M12 (4-pin) connector can be connected.

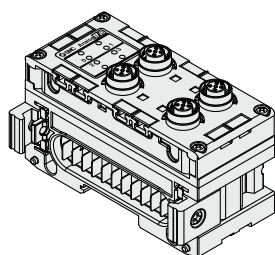
EX600-AMB
Analog Input/Output Unit

Model		EX600-AMB		
Input	Input type	Voltage input	Current input	
	Input connector	M12 (5-pin) socket ^{Note 1)}		
	Input channel	2 channels (1 channel/Connector)		
	Supplied voltage	24 VDC		
	Max. supplied current	0.5 A/Connector		
	Protection	Short-circuit protection		
	Input signal range	12 bit resolution 0 to 10 V, 1 to 5 V, 0 to 5 V	0 to 20 mA, 4 to 20 mA	
	Max. rated input signal	15 V	22 mA ^{Note 2)}	
	Input impedance	100 kΩ	250 Ω	
	Linearity (25°C)	±0.05% F.S.		
	Repeatability (25°C)	±0.15% F.S.		
	Absolute accuracy (25°C)	±0.5% F.S.	±0.6% F.S.	
	Output	Output type	Voltage output	Current output
		Output connector	M12 (5-pin) socket ^{Note 1)}	
Output channel		2 channels (1 channel/Connector)		
Supplied voltage		24 VDC		
Max. load current		0.5 A/Connector		
Protection		Short-circuit protection		
Output signal range		12 bit resolution 0 to 10 V, 1 to 5 V, 0 to 5 V	0 to 20 mA, 4 to 20 mA	
Load impedance		1 kΩ or more	600 Ω or less	
Linearity (25°C)		±0.05% F.S.		
Repeatability (25°C)		±0.15% F.S.		
Absolute accuracy (25°C)	±0.5% F.S.	±0.6% F.S.		
Current consumption	100 mA or less			
Enclosure	IP67 (Manifold assembly)			
Standards	CE Marking, UL (CSA), RoHS compliant			
Weight	300 g			

Note 1) M12 (4-pin) connector can be connected.

Note 2) When input signal exceeds 22 mA, the protection function activates and the input signal is interrupted.

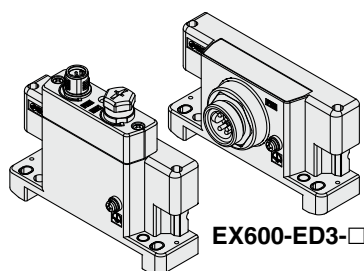
EX600-ED2-□
EX600-ED3-□
End Plate

Model		EX600-ED2-□	EX600-ED3-□
Power specifications	Power connector	M12 (5-pin) plug	7/8 inch (5-pin) plug
	Power supply (for Control/Input)	24 VDC ±10%, Class 2, 2 A	24 VDC ±10%, 8 A
	Power supply (for Output)	24 VDC +10/-5%, Class 2, 2 A	24 VDC +10/-5%, 8 A
Enclosure	IP67 (Manifold assembly)		
Standards	CE Marking, UL (CSA), RoHS compliant		
Weight	170 g	175 g	

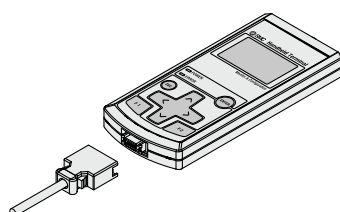

EX600-HT1A-□
Handheld Terminal

Model	EX600-HT1A-□
Power supply	Power supplied from SI Unit connector (24 VDC)
Current consumption	50 mA or less
Display	LCD with backlight
Connection cable	Handheld Terminal cable (1 m ... EX600-AC010-1, 3 m ... EX600-AC030-1)
Enclosure	IP20
Standards	CE Marking, RoHS compliant
Weight	160 g

Series EX600

Parts Description

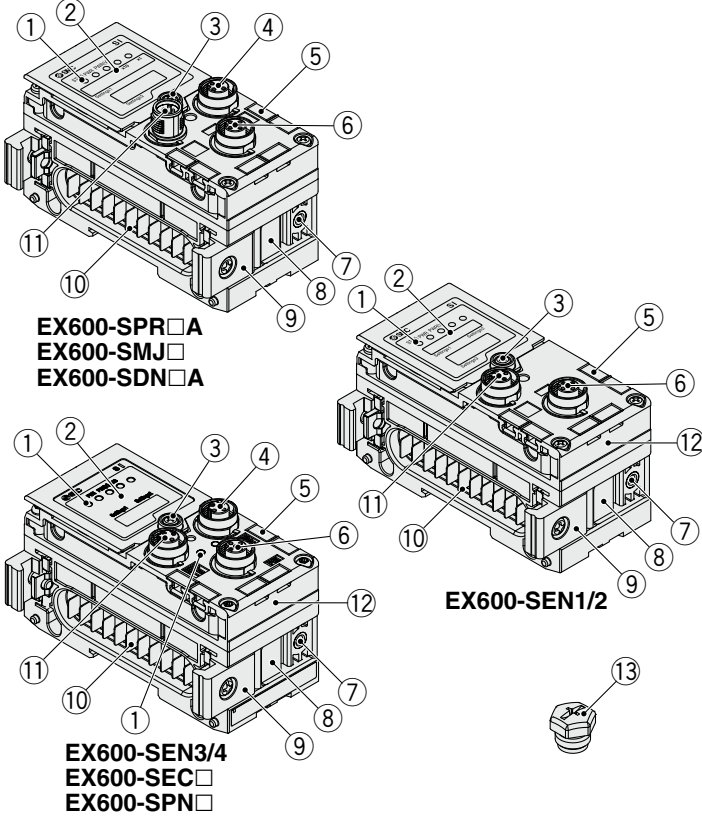
SI Unit



No.	Name	Use
1	Status indication LED	Displays Unit status.
2	Indication cover	Open for setting the switch.
3	Indication cover set screw	Loosen for opening the indication cover.
4	Connector (BUS OUT)	Connects to the fieldbus output cable.
5	Marker groove	Can be used to mount a marker.
6	Connector (PCI)	Connects to the Handheld Terminal cable.
7	Valve plate mounting holes	Fixes a valve plate in place.
8	Valve plate mounting groove	Inserts a valve plate.
9	Joint bracket	Links Units to one another.
10	Connector for Unit (Plug)	Transmits signals to the neighboring Unit and supplies power.
11	Connector (BUS IN)	Connects to the cable for fieldbus input.
12	MAC address name plate ^{Note)}	Displays a unique 12-digit MAC address for each SI Unit.
13	Seal cap	Mounted on the connectors (BUS OUT and PCI) at the time of shipment.

Note) MAC address name plate is not provided on the EX600-SEC□.

Handheld Terminal

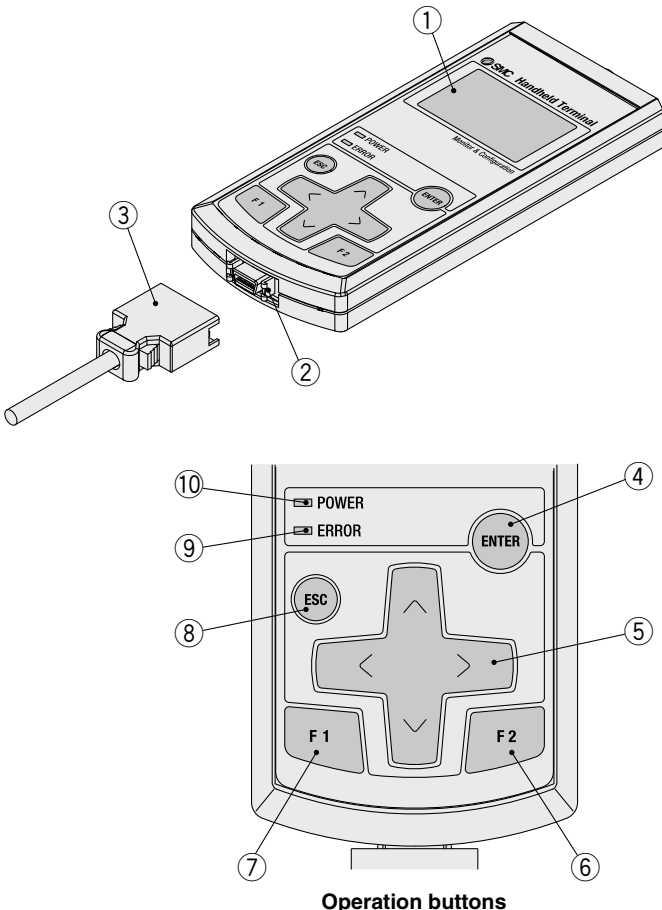

No.	Name	Use
1	LCD	Displays operation and Unit information.
2	Connector	Connects to the Handheld Terminal cable.
3	Handheld Terminal cable	Connects the SI Unit to the Handheld Terminal.
4	Enter button (ENTER)	From the selection screen, goes to the screen for the item selected. On the settings screen, registers the settings that have been made so far.
5	Cursor button (↑ ↓ ← →)	Moves the cursor on the LCD up, down, left or right. Moves the cursor on the selection screen up, down, left or right to make selections. On the settings screen, increases or decreases the value of settings or turns settings on and off.
6	F2 button (F2)	Functions in accordance with on-screen display or instructions.
7	F1 button (F1)	Functions in accordance with on-screen display or instructions.
8	Escape button (ESC)	On the selection screen, goes back to the previous screen. On the settings screen, cancels the settings that have been made so far and goes back to the previous screen.
9	ERROR LED	Lights up red when the EX600 diagnosis errors occur.
10	POWER LED	Connects to the EX600 SI Unit, and lights up green when control/input power supply is on.

Digital Unit

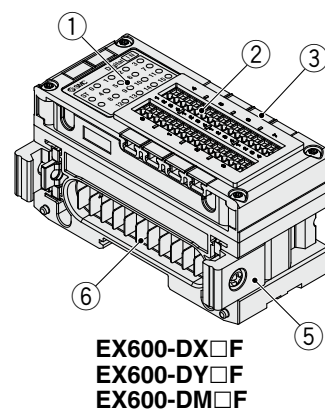
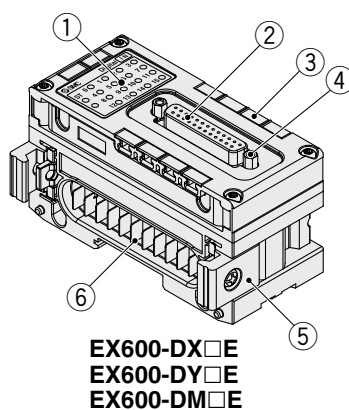
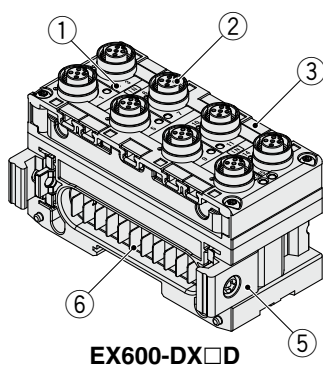
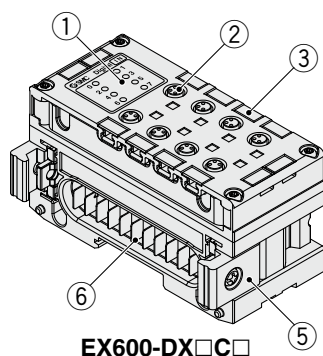
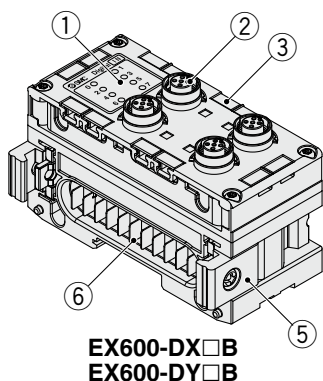

No.	Name	Use
1	Status indication LED	Displays Unit status.
2	Connector	Connects with input or output devices.
3	Marker groove	Can be used to mount a marker.
4	Lock screw	Fixes the D-sub connector in place. (No.4-40 UNC)
5	Joint bracket	Links Units to one another.
6	Connector for Unit (Plug)	Transmits signals to the neighboring Unit and supplies power.

Analog Unit

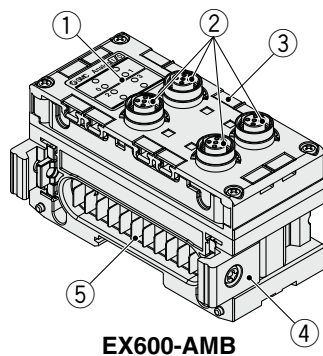
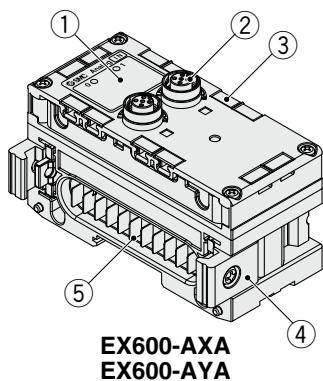

No.	Name	Use
1	Status indication LED	Displays Unit status.
2	Connector	Connects with input or output devices.
3	Marker groove	Can be used to mount a marker.
4	Joint bracket	Links Units to one another.
5	Connector for Unit (Plug)	Transmits signals to the neighboring Unit and supplies power.

End Plate

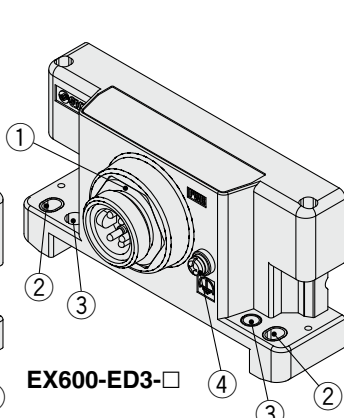
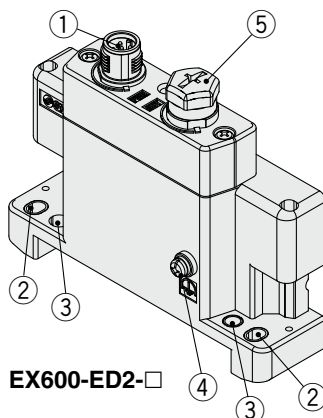

No.	Name	Use
1	Power connector	Supplies power to the Unit and/or input/output devices.
2	Fixing hole for direct mounting	Connects directly to equipment.
3	Fixing hole for DIN rail	Converts to manifold or for DIN rail mounting.
4	FE terminal	Used for grounding. Ground this terminal securely to improve the noise immunity.
5	Connector (Unused)	This connector has not yet been used. Do not remove the seal cap.

Series EX600

Series SY

Series SV

Series S0700

Series VQC

Series EX600

Dimensions

SI Unit

EX600-SPR□A
EX600-SDN□A
EX600-SMJ□

EX600-SEN□
EX600-SEC□
EX600-SPN□

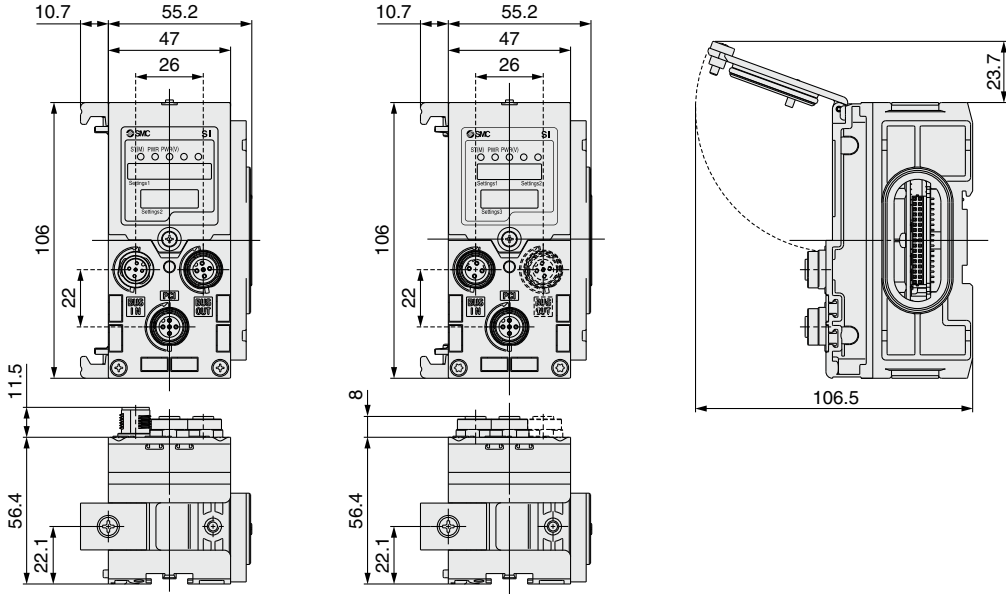

End Plate

EX600-ED2

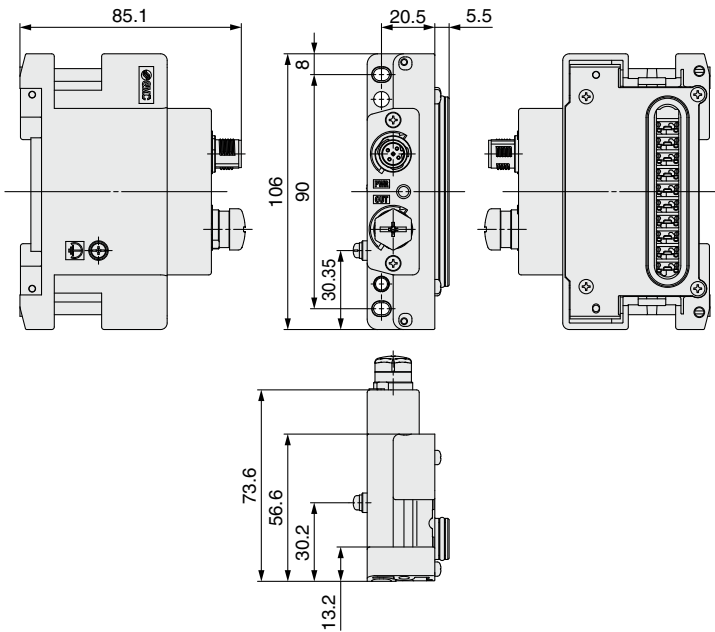

EX600-ED3

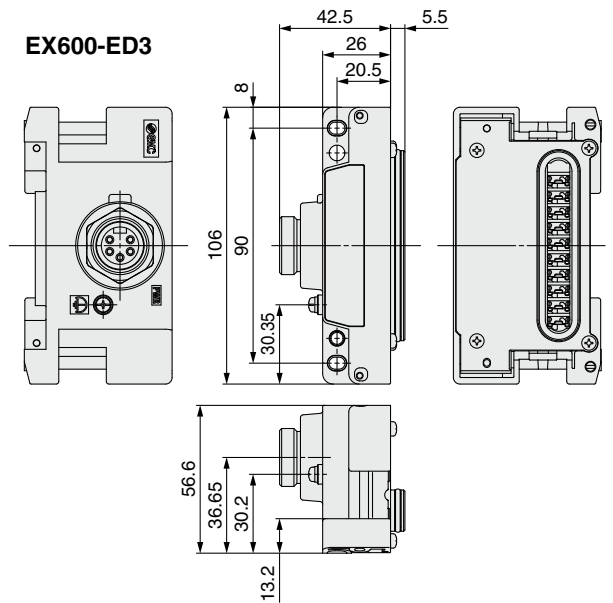

Handheld Terminal

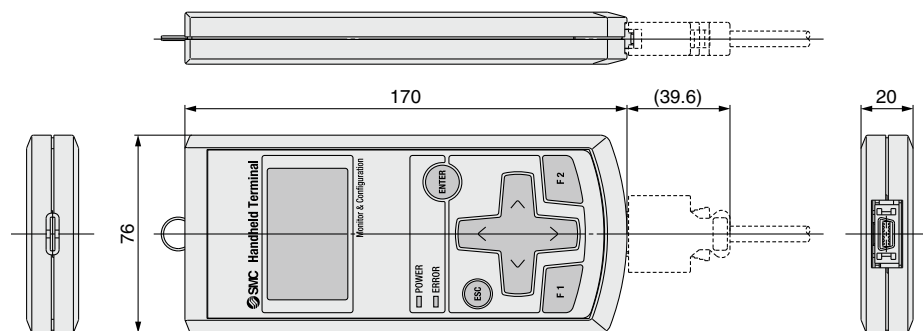

Digital Unit

EX600-DX□B
EX600-DY□B

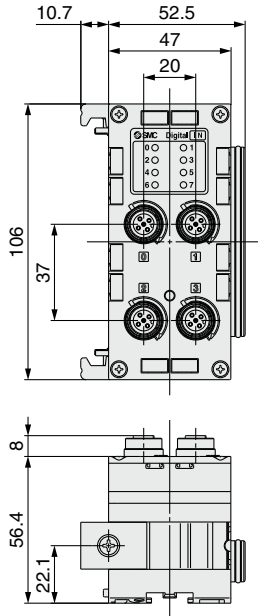

EX600-DX□C□

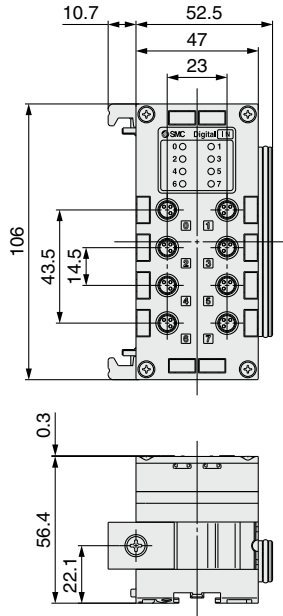

EX600-DX□D

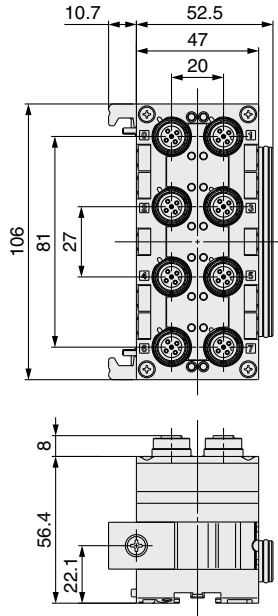

EX600-DX□E
EX600-DY□E
EX600-DM□E

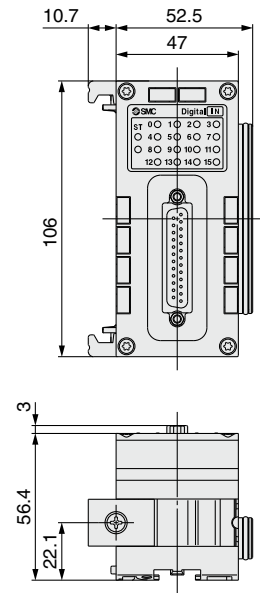

EX600-DX□F
EX600-DY□F
EX600-DM□F

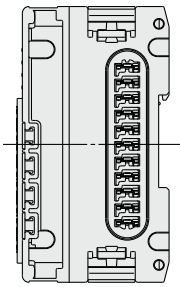
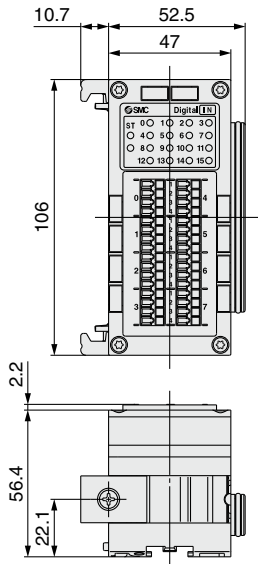

Analog Unit

EX600-AXA
EX600-AYA

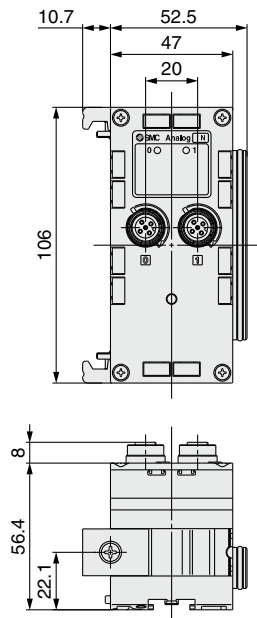

EX600-AMB

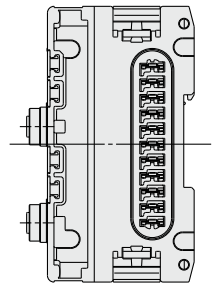
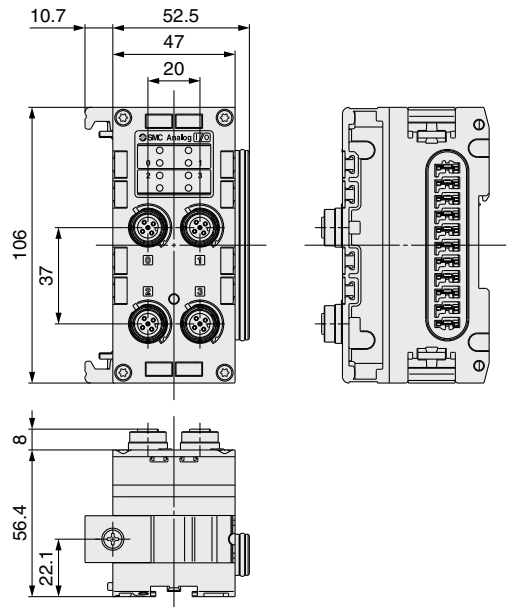

Series EX600

Series SY

Series SV

Series S0700

Series VQC

Series EX600 Accessories

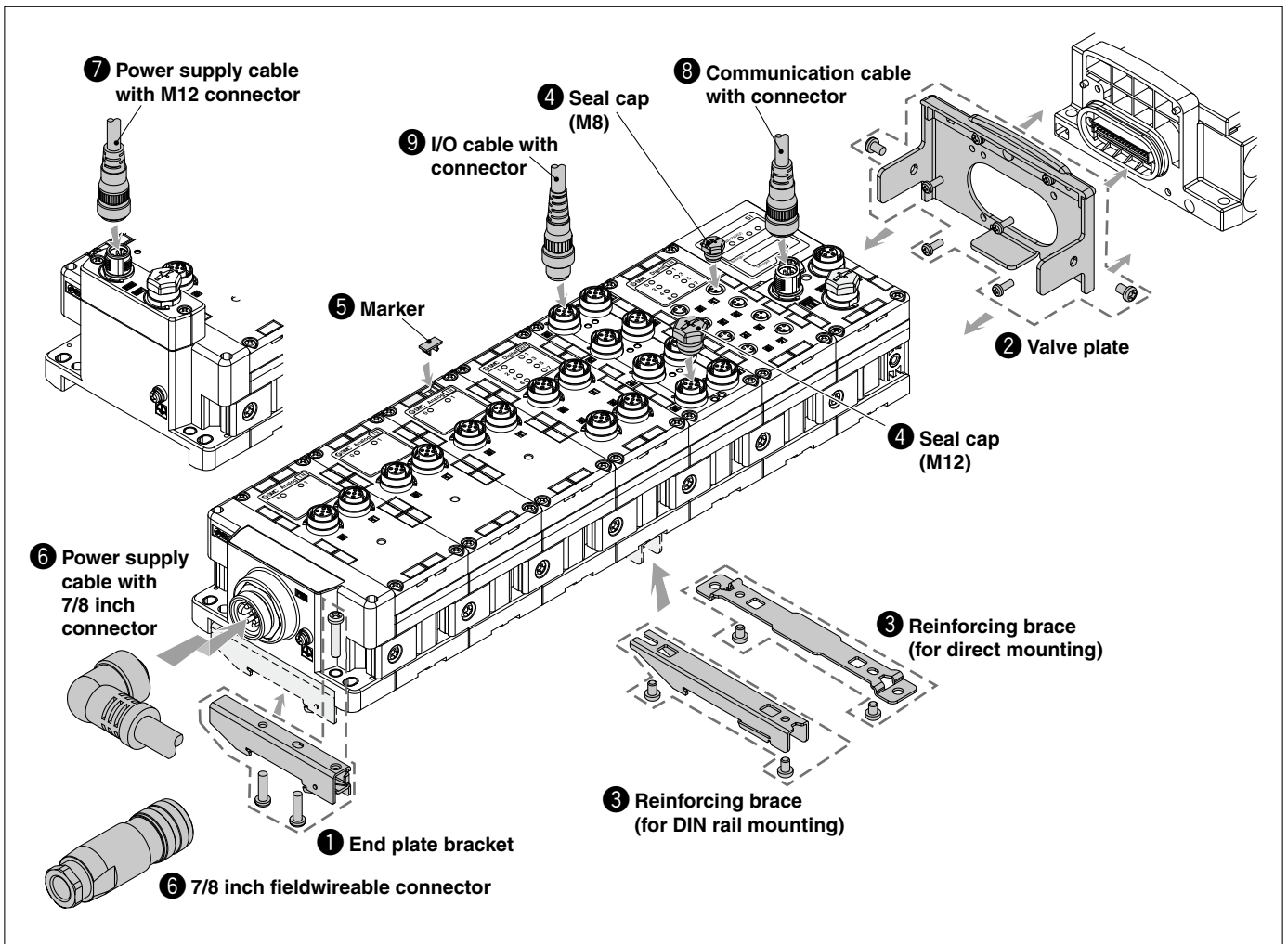

1 End Plate Bracket

This bracket is used for the end plate of DIN rail mounting.



EX600-ZMA2

Enclosed parts

Round head screw (M4 x 20) 1 pc.
P-tight screw (4 x 14) 2 pcs.

**EX600-ZMA3
(Specialized for SY series)**

Enclosed parts

Round head screw with washer (M4 x 20) 1 pc.
P-tight screw (4 x 14) 2 pcs.

2 Valve Plate

EX600-ZMV1

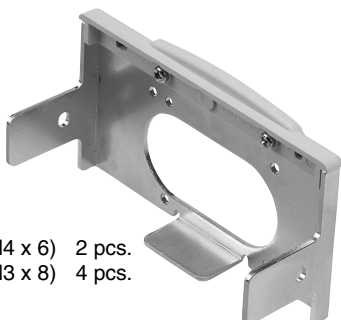

Enclosed parts

Round head screw (M4 x 6) 2 pcs.
Round head screw (M3 x 8) 4 pcs.

**EX600-ZMV2
(Specialized for SY series)**



Enclosed parts

Round head screw (M4 x 6) 2 pcs.
Round head screw (M3 x 8) 4 pcs.

③ Reinforcing Brace

This bracket is used on the bottom of the Unit at the intermediate position for connecting 6 Units or more.
 (Note) Be sure to attach this bracket to prevent connection failure between the Units caused by deflection.

For direct mounting
EX600-ZMB1

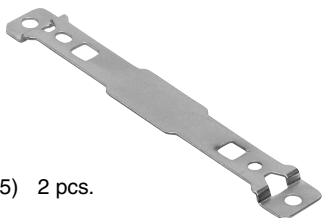

Enclosed parts
 Round head screw (M4 x 5) 2 pcs.

For DIN rail mounting
EX600-ZMB2

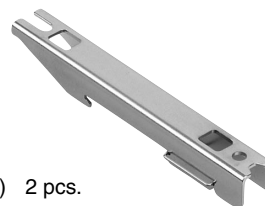

Enclosed parts
 Round head screw (M4 x 6) 2 pcs.

④ Seal Cap (10 pcs.)

Be sure to mount a seal cap on any unused I/O connectors. Otherwise, the specified enclosure cannot be maintained.

EX9-AWES
 For M8



EX9-AWTS
 For M12



⑤ Marker (1 sheet, 88 pcs.)

The signal name of I/O device and each Unit address can be entered and mounted on each Unit.

EX600-ZT1

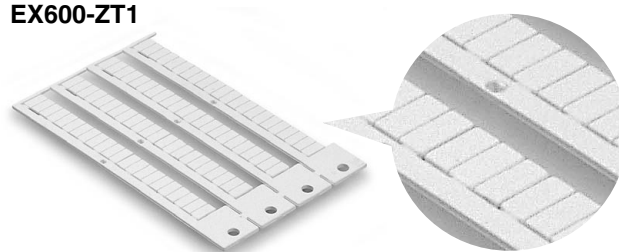

⑥ 7/8 Inch Connector and Its Related Parts

• **Power supply cable with 7/8 inch connector**

- PCA-1558810 Straight 2 m
- PCA-1558823 Straight 6 m
- PCA-1558836 Right angle 2 m
- PCA-1558849 Right angle 6 m



• **Fieldwireable 7/8 inch connector [compatible to AWG22-16]**

- PCA-1578078 Plug
- PCA-1578081 Socket



⑦ Power Supply Cable with M12 Connector (5-pin B-coded)

- PCA-1564927 Straight 2 m
- PCA-1564930 Straight 6 m
- PCA-1564943 Right angle 2 m
- PCA-1564969 Right angle 6 m



SPEEDCON

(Note) For M12 connector, description of B-coded for a reverse type is used as a connector shape.



Series EX600
Series SY
Series SV
Series S0700
Series VQC

Series EX600

⑧ Communication Cable with Connector/Communication Connector

For SI Unit compatible with CC-Link, DeviceNet™ and PROFIBUS DP

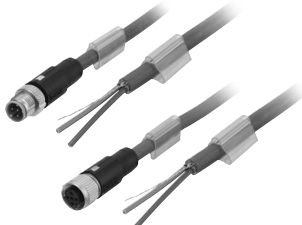
For details, refer to the M8/M12 connector catalog available on SMC website.

Name	Use	Part no.	Description
Cable with connector SPEEDCON	For Fieldbus communication 	PCA-1567720	Communication cable for CC-Link (Socket)
		PCA-1567717	Communication cable for CC-Link (Plug)
		PCA-1557633	Communication cable for DeviceNet™ (Socket)
		PCA-1557646	Communication cable for DeviceNet™ (Plug)
		PCA-1557688	Communication cable for PROFIBUS DP (Socket/B-coded)
		PCA-1557691	Communication cable for PROFIBUS DP (Plug/B-coded)
Fieldwireable connector	For Fieldbus communication 	PCA-1557617	Fieldwireable connector for CC-Link (Plug/Spring-caged)
		PCA-1557620	Fieldwireable connector for CC-Link (Socket/Spring-caged)
		PCA-1557659	Fieldwireable connector for DeviceNet™ (Plug/Spring-caged)
		PCA-1557662	Fieldwireable connector for DeviceNet™ (Socket/Spring-caged)
		PCA-1557701	Fieldwireable connector for PROFIBUS DP (Plug/B-coded/Spring-caged)
		PCA-1557714	Fieldwireable connector for PROFIBUS DP (Socket/B-coded/Spring-caged)

For SI Unit compatible with EtherNet/IP™, EtherCAT® and PROFINET

Cable with connector

Fieldwireable connector

PCA-1446566

SPEEDCON

Cable length

1446566 5000 [mm]

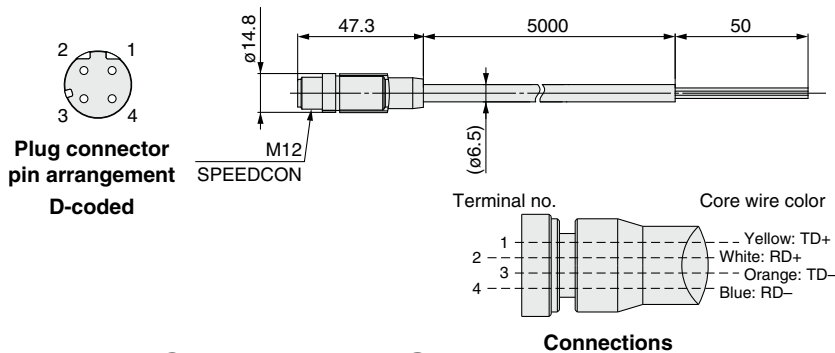

PCA-1446553

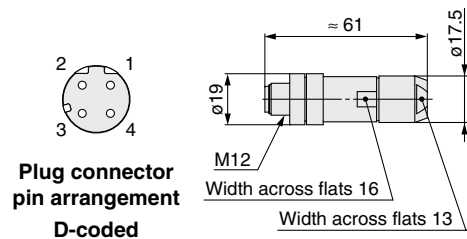

EX9-AC 020 EN - PSRJ

Cable length

010	1000 [mm]
020	2000 [mm]
030	3000 [mm]
050	5000 [mm]
100	10000 [mm]

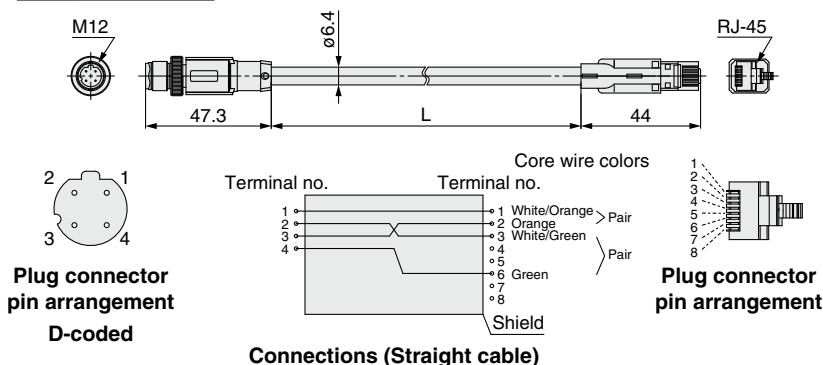

Connector specification

PSRJ M12 plug (straight) \leftrightarrow RJ-45 connector

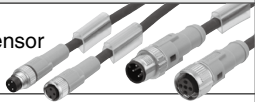

9 I/O Cable with Connector/I/O Connector

For details, refer to the M8/M12 connector catalog available on SMC website.

Name	Use	Part no.	Description
Cable with connector		PCA-1557769	Cable with M12 connector (4 pins/3 m)
		PCA-1557772	Cable with M8 connector (3 pins/3 m)
Fieldwireable connector		PCA-1557730	Fieldwireable connector (M8/3 pins/Plug/Piercecon® connection)
		PCA-1557743	Fieldwireable connector
		PCA-1557756	(M12/4 pins/Plug/QUICKON-ONE connection/SPEEDCON)
Y connector		PCA-1557785	Y connector (2 x M12 (5 pins)-M12 (5 pins)/SPEEDCON)
		PCA-1557798	Y connector (2 x M8 (3 pins)-M12 (4 pins)/SPEEDCON)

Note) When using the Y connector, connect it to the connector on the I/O Unit through the sensor cable (PCA-1557769) with the M12 connector.

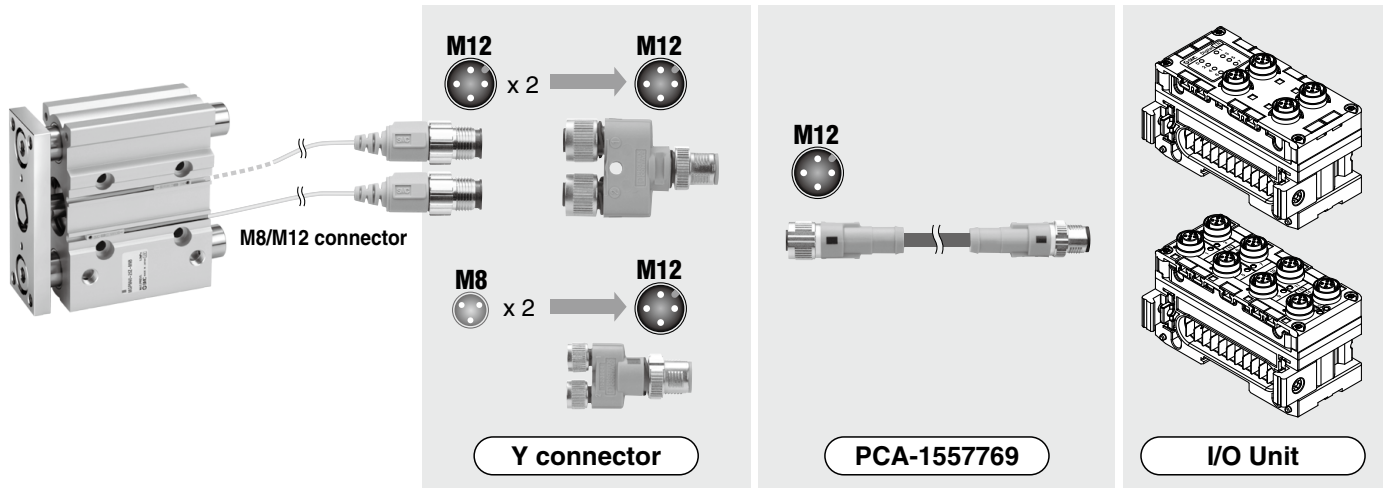

M8/M12 connector

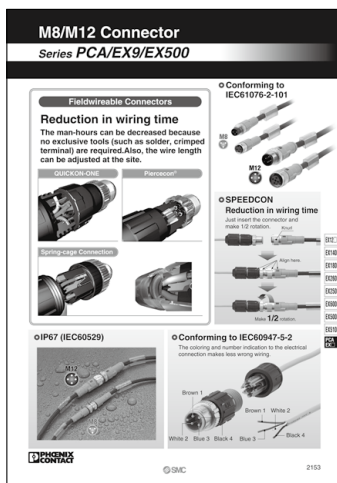

For details about the cables and connectors that can be purchased from SMC, refer to the **WEB catalog** or the Best Pneumatics No. 1.

Series EX600

Series SY

Series SV

Series S0700

Series VQC

Series EX600

Table of Mountable Units

The Units that can be connected differ depending on the product number.
Before mounting, please check the types of Units that can be connected.

○: Acceptable
×: Not acceptable

**Table of Compatible Units
Mountable with Each SI Unit**

		Product number				
		SI Unit				
		EX600-SPR□ (PROFIBUS DP) EX600-SDN□ (DeviceNet™)	EX600-SPR□A (PROFIBUS DP) EX600-SDN□A (DeviceNet™)	EX600-SMJ□ (CC-Link)	EX600-SEN□ (EtherNet/IP™) EX600-SEC□ (EtherCAT®) EX600-SPN□ (PROFINET)	
		Version Nil	Version A	Version Nil	Version Nil	
Product number	Digital Input Unit	EX600-DX□B	○	○	○	○
		EX600-DX□C□	○	○	○	○
		EX600-DX□D	○	○	○	○
		EX600-DX□E	×	○	○	○
		EX600-DX□F	×	○	○	○
	Digital Output Unit	EX600-DY□B	○	○	○	○
		EX600-DY□E	×	○	○	○
		EX600-DY□F	×	○	○	○
	Digital Input/Output Unit	EX600-DM□E	×	○	○	○
		EX600-DM□F	×	○	○	○
	Analog Input Unit	EX600-AXA	○	○	○	○
	Analog Output Unit	EX600-AYA	×	○	○	○
	Analog Input/Output Unit	EX600-AMB	×	○	○	○
	Handheld Terminal	EX600-HT1-□	○	○	○	×
EX600-HT1A-□		○	○	○	○	

**Table of Compatible Units Capable of
Communication with Handheld Terminals**

		Product number		
		Handheld Terminal		
		EX600-HT1-□	EX600-HT1A-□	
		Version Nil	Version A	
Product number	SI Unit	EX600-SPR□ (PROFIBUS DP)	○	○
		EX600-SPR□A (PROFIBUS DP)	○	○
		EX600-SDN□ (DeviceNet™)	○	○
		EX600-SDN□A (DeviceNet™)	○	○
		EX600-SMJ□ (CC-Link)	○	○
		EX600-SEN□ (EtherNet/IP™)	×	○
		EX600-SEC□ (EtherCAT®)	×	○
		EX600-SPN□ (PROFINET)	×	○
	Digital Input Unit	EX600-DX□B	○	○
		EX600-DX□C□	○	○
		EX600-DX□D	○	○
		EX600-DX□E	×	○
		EX600-DX□F	×	○
	Digital Output Unit	EX600-DY□B	○	○
EX600-DY□E		×	○	
EX600-DY□F		×	○	
Digital Input/Output Unit	EX600-DM□E	×	○	
	EX600-DM□F	×	○	
Analog Input Unit	EX600-AXA	○	○	
Analog Output Unit	EX600-AYA	×	○	
Analog Input/Output Unit	EX600-AMB	×	○	

Manifold Solenoid Valves for *Series EX600*

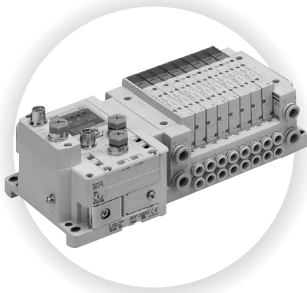

Series SY3000/5000/7000

Type 10 Side Ported/Type 11 Bottom Ported **P. 27**

Type 12 Top Ported **P. 37**

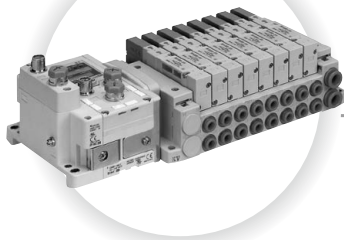

Series SV1000/2000/3000

P. 39

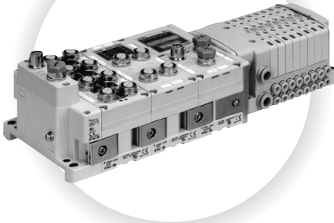

Series S0700

P. 47

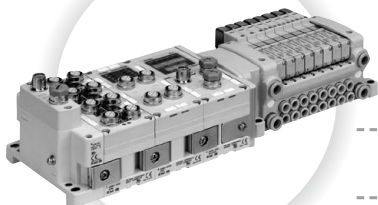

Series VQC1000

P. 51

Series VQC2000

P. 55

Series VQC4000

P. 59

EX600

5 Port Solenoid Valve

Series SV1000/2000/3000

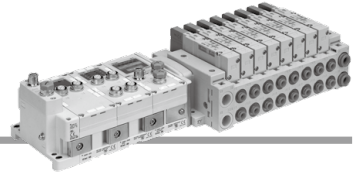

How to Order Manifold

● Tie-rod Base

SS5V **1** - **10S6** **Q** **□** **□** **□** **D** - **05** **U** **□** - **C6** - **□**

Series

1	SV1000
2	SV2000
3	SV3000

Enclosure

Nil	IP40
W	IP67

- When I/O Unit EX600-D□□E or EX600-D□□F are selected, enclosure is IP40. Refer to page 64 for details.

SI Unit

0	Without SI Unit
Q	DeviceNet™
N	PROFIBUS DP
V	CC-Link
ZE	EtherNet/IP™ (1 port)
EA	EtherNet/IP™ (2 ports)
D	EtherCAT®
F	PROFINET

- When "Without SI Unit" is specified, I/O Unit cannot be mounted.
- When "Without SI Unit" is specified, a valve plate which connects the valve manifold and SI Unit, is not mounted. Refer to page 65 for mounting method.

End plate type

Nil	No end plate
2	Power supply with M12 connector (Max. supplied current 2 A)
3	Power supply with 7/8 inch connector (Max. supplied current 8 A)

- Without SI Unit, the symbol is nil.

SI Unit output polarity

Nil	Positive common
N	Negative common

- Without SI Unit, the symbol is nil.

I/O Unit stations

Nil	None
1	1 station
:	:
9	9 stations

- Without SI Unit, the symbol is nil.
- SI Unit is not included in I/O Unit stations.
- When I/O Unit is selected, it is shipped separately and assembled by users. Refer to the attached operation manual for mounting method.

Mounting

Nil	Direct mounting
D	DIN rail mounting (With DIN rail)
D0 ^{Note 1)}	DIN rail mounting (Without DIN rail)
D3	For 3 stations
:	:
D20	For 20 stations

- Note 1) In the case of D0, only DIN rail mounting bracket is attached.
- Note 2) DIN rail is not attached (but shipped together) on the manifold in the case of with DIN rail. Refer to the SV series catalog for mounting method.
- Note 3) When selecting the DIN rail mounting (with DIN rail) of the SV3000 series, and 9 I/O Unit stations will result in a total of 18 valve stations. With 19 and 20 stations, the DIN rail mounting (with DIN rail) cannot be indicated, so please exercise caution. (Refer to "DIN Rail Overall Length" on pages 45 and 46.)
- Note 4) When it is necessary to mount a DIN rail without an SI Unit, select D0 and order the DIN rail with required length separately by referring to L1 in the dimensions.

● SUP/EXH block assembly

Nil	Internal pilot
S ^{Note)}	Internal pilot, Built-in silencer
R	External pilot
RS ^{Note)}	External pilot, Built-in silencer

- Note) When built-in silencer type is used, keep the exhaust port from coming in direct contact with water or other liquids.

Valve stations

Symbol	Stations	Note
02	2 stations	Double wiring ^{Note 1)}
:	:	
16	16 stations	
02	2 stations	Specified layout ^{Note 2)} (Available up to 32 solenoids)
:	:	
20	20 stations	

- Note 1) Double wiring: single, double, 3-position and 4-position valves can be used on all manifold stations. Use of a single solenoid will result in an unused control signal. If this is not desired, order with a specified layout.
- Note 2) Specified layout: Indicate the wiring specifications on the manifold specification sheet. (Note that double, 3-position and 4-position valves cannot be used where single wiring has been specified.)

● P, E port entry

U	U side (2 to 10 stations)
D	D side (2 to 10 stations)
B	Both sides (2 to 20 stations)

A, B port size (Metric)

Symbol	A, B port	P, E port	Applicable series
C3	ø3.2 One-touch fitting	ø8 One-touch fitting	SV1000
C4	ø4 One-touch fitting		
C6	ø6 One-touch fitting		
C4	ø4 One-touch fitting	ø10 One-touch fitting	SV2000
C6	ø6 One-touch fitting		
C8	ø8 One-touch fitting		
C6	ø6 One-touch fitting	ø12 One-touch fitting	SV3000
C8	ø8 One-touch fitting		
C10	ø10 One-touch fitting		
M	A, B port mixed		

A, B port size (Inch)

Symbol	A, B port	P, E port	Applicable series
N1	ø1/8" One-touch fitting	ø5/16" One-touch fitting	SV1000
N3	ø5/32" One-touch fitting		
N7	ø1/4" One-touch fitting		
N3	ø5/32" One-touch fitting	ø3/8" One-touch fitting	SV2000
N7	ø1/4" One-touch fitting		
N9	ø5/16" One-touch fitting		
N7	ø1/4" One-touch fitting	ø3/8" One-touch fitting	SV3000
N9	ø5/16" One-touch fitting		
N11	ø3/8" One-touch fitting		
M	A, B port mixed		

* In the case of mixed specifications (M), indicate separately on the manifold specification sheet.

* The X and PE port size of External pilot type (R), and X port size of External pilot, Built-in silencer type (RS) are ø4 (mm) or ø5/32" (inch) for the SV1000/2000 series, and ø6 (mm) or ø1/4" (inch) for the SV3000 series.

How to Order Manifold Assembly

Example (SS5V1)

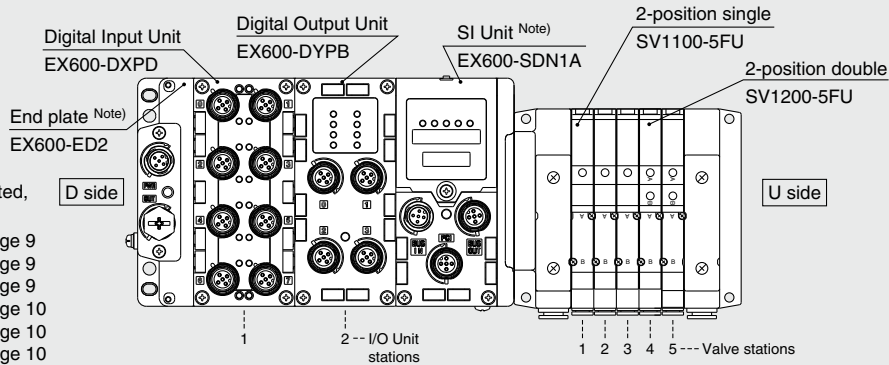

For the I/O Unit part number mounted, refer to the following pages.

- Digital Input Unit Page 9
- Digital Output Unit Page 9
- Digital Input/Output Unit Page 9
- Analog Input Unit Page 10
- Analog Output Unit Page 10
- Analog Input/Output Unit Page 10

SS5V1-W10S6Q2N2D-05B-C6 1 set	Manifold base part number	Enter in order starting from the first station on the D side. If the arrangement becomes complicated, specify on the manifold specification sheet.
* SV1100-5FU 3 sets	Valve part number (Stations 1 to 3)	
* SV1200-5FU 2 sets	Valve part number (Stations 4 to 5)	Enter in order starting from the first station on the D side. If the arrangement becomes complicated, specify on the manifold specification sheet.
* EX600-DXPD 1 set	I/O Unit part number (Station 1)	
* EX600-DYPB 1 set	I/O Unit part number (Station 2)	Note) Do not enter the SI Unit part number and the end plate part number together.

→The asterisk denotes the symbol for assembly.
Prefix it to the part numbers of the solenoid valve etc.

How to Order Valves

SV 1 1 00 - 5 FU

Series

1	SV1000
2	SV2000
3	SV3000

Made to Order

Nil	—
X90	Fluororubber specification

Type of actuation

1	2-position single
2	2-position double
3	3-position closed center
4	3-position exhaust center
5	3-position pressure center
A	4-position dual 3-port valve (N.C./N.C.)
B	4-position dual 3-port valve (N.O./N.O.)
C	4-position dual 3-port valve (N.C./N.O.)

* 4-position dual 3-port valves are applicable to the SV1000/2000 series only.

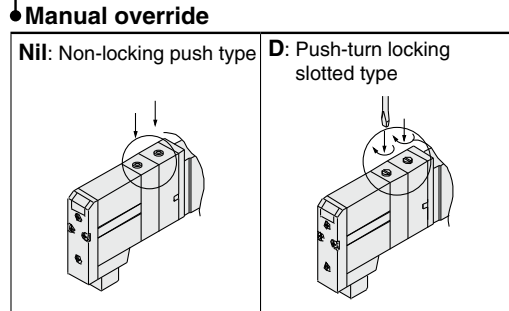

Pilot type

Nil	Internal pilot
R	External pilot

* External pilot type is not available for 4-position dual 3-port valves.

Light/surge voltage suppressor

U	With light/surge voltage suppressor
R	With surge voltage suppressor

Rated voltage

5	24 VDC
---	--------

Back pressure check valve

Nil	None
K	Built-in

* Built-in back pressure check valve type is applicable to the SV1000 series only.

* The product with a back pressure check valve is not available for 3-position valves.

Refer to the catalog of each series for details on manifold solenoid valve specifications, Common Precautions and Specific Product Precautions.

Series SV1000/2000/3000

Series SV1000

Dimensions

Power supply with M12 connector

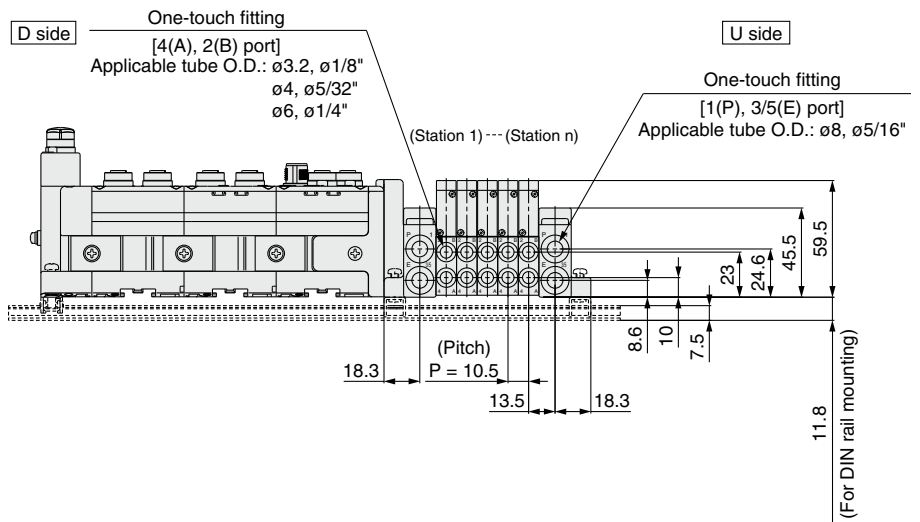
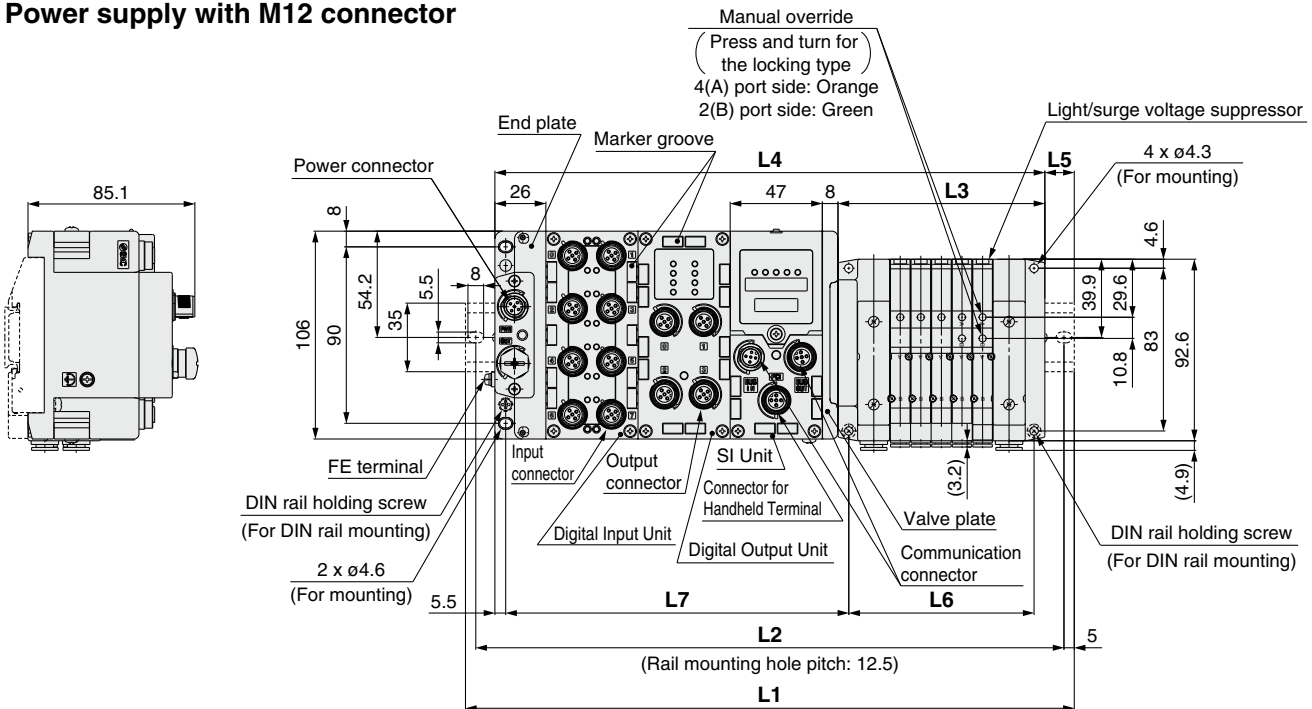

$$L2 = L1 - 10.5$$

$$L3 = 10.5 \times n1 + 53$$

$$L4 = L3 + 81 + 47 \times n2$$

$$L5 = (L1 - L4)/2$$

$$L6 = 10.5 \times n1 + 42$$

$$L7 = 47 \times n2 + 81$$

n1: Valve stations
n2: I/O Unit stations

L1: DIN Rail Overall Length

Valve stations (n1) / I/O Unit stations (n2)	[mm]																			
	2	3	4	5	6	7	8	9	10	11	12	13	14	15	16	17	18	19	20	
0	185.5	198	210.5	210.5	223	235.5	248	260.5	273	273	285.5	298	310.5	323	335.5	348	348	360.5	373	
1	235.5	248	248	260.5	273	285.5	298	310.5	310.5	323	335.5	348	360.5	373	373	385.5	398	410.5	423	
2	273	285.5	298	310.5	323	335.5	335.5	348	360.5	373	385.5	398	410.5	410.5	423	435.5	448	460.5	473	
3	323	335.5	348	360.5	373	373	385.5	398	410.5	423	435.5	435.5	448	460.5	473	485.5	498	498	510.5	
4	373	385.5	398	398	410.5	423	435.5	448	460.5	473	473	485.5	498	510.5	523	535.5	535.5	548	560.5	
5	423	435.5	435.5	448	460.5	473	485.5	498	498	510.5	523	535.5	548	560.5	560.5	573	585.5	598	610.5	
6	460.5	473	485.5	498	510.5	523	535.5	535.5	548	560.5	573	585.5	598	598	610.5	623	635.5	648	660.5	
7	510.5	523	535.5	548	560.5	560.5	573	585.5	598	610.5	623	623	635.5	648	660.5	673	685.5	698	698	
8	560.5	573	585.5	598	598	610.5	623	635.5	648	660.5	660.5	673	685.5	698	710.5	723	723	735.5	748	
9	610.5	623	623	635.5	648	660.5	673	685.5	685.5	698	710.5	723	735.5	748	760.5	760.5	773	785.5	798	

Dimensions

Series SV1000

Power supply with 7/8 inch connector

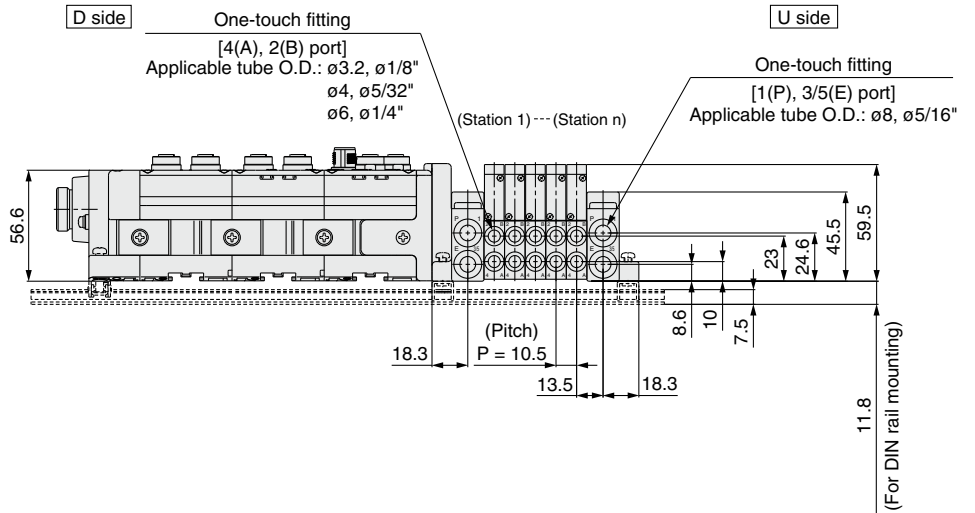
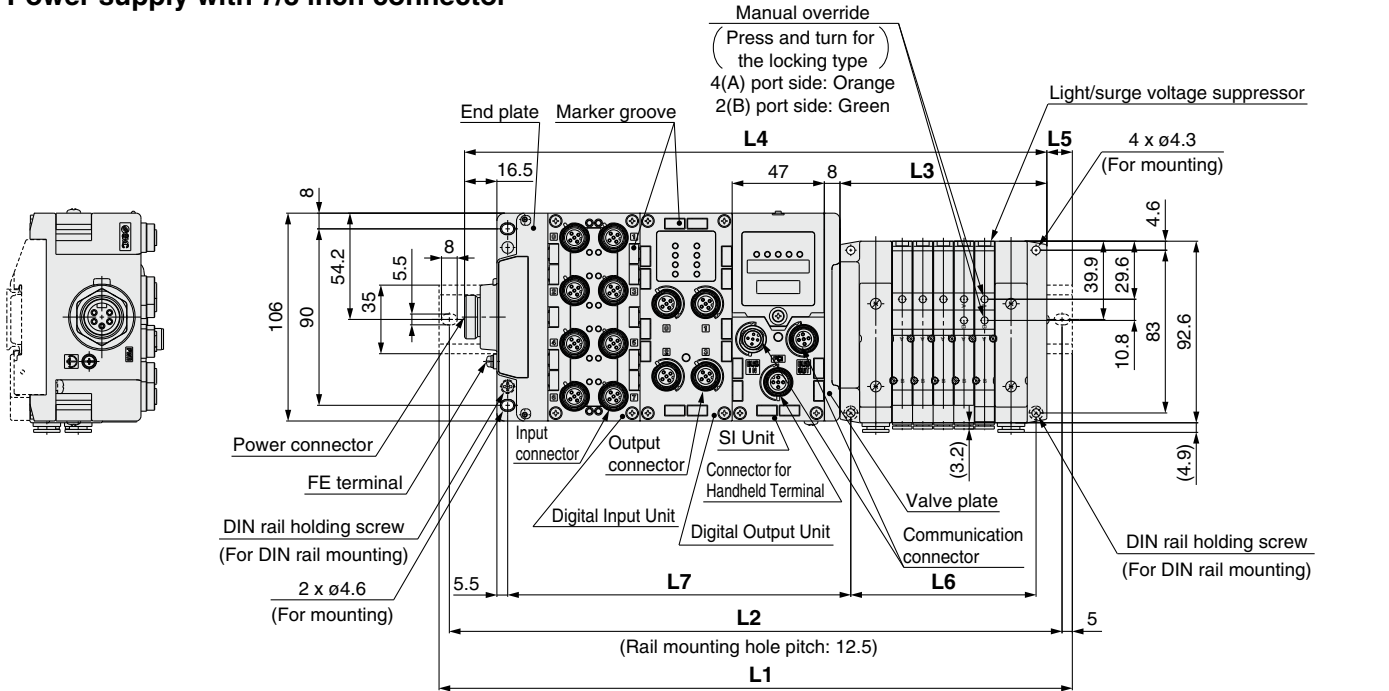

$L2 = L1 - 10.5$
 $L3 = 10.5 \times n1 + 53$
 $L4 = L3 + 97.5 + 47 \times n2$
 $L5 = (L1 - L4)/2$
 $L6 = 10.5 \times n1 + 42$
 $L7 = 47 \times n2 + 81$

n1: Valve stations
n2: I/O Unit stations

L1: DIN Rail Overall Length

Valve stations (n1) I/O Unit stations (n2)	[mm]																			
	2	3	4	5	6	7	8	9	10	11	12	13	14	15	16	17	18	19	20	
0	198	210.5	223	235.5	248	248	260.5	273	285.5	298	310.5	310.5	323	335.5	348	360.5	373	385.5	385.5	
1	248	260.5	273	285.5	285.5	298	310.5	323	335.5	348	348	360.5	373	385.5	398	410.5	410.5	423	435.5	
2	298	310.5	310.5	323	335.5	348	360.5	373	373	385.5	398	410.5	423	435.5	448	448	460.5	473	485.5	
3	348	348	360.5	373	385.5	398	410.5	410.5	423	435.5	448	460.5	473	473	485.5	498	510.5	523	535.5	
4	385.5	398	410.5	423	435.5	435.5	448	460.5	473	485.5	498	510.5	510.5	523	535.5	548	560.5	573	573	
5	435.5	448	460.5	473	473	485.5	498	510.5	523	535.5	535.5	548	560.5	573	585.5	598	598	610.5	623	
6	485.5	498	498	510.5	523	535.5	548	560.5	573	573	585.5	598	610.5	623	635.5	635.5	648	660.5	673	
7	535.5	535.5	548	560.5	573	585.5	598	598	610.5	623	635.5	648	660.5	660.5	673	685.5	698	710.5	723	
8	573	585.5	598	610.5	623	635.5	635.5	648	660.5	673	685.5	698	698	710.5	723	735.5	748	760.5	760.5	
9	623	635.5	648	660.5	660.5	673	685.5	698	710.5	723	723	735.5	748	760.5	773	785.5	798	798	810.5	

Series EX600

Series SY

Series SV

Series S0700

Series VQC

Series SV1000/2000/3000

Series **SV2000**

Dimensions

Power supply with M12 connector

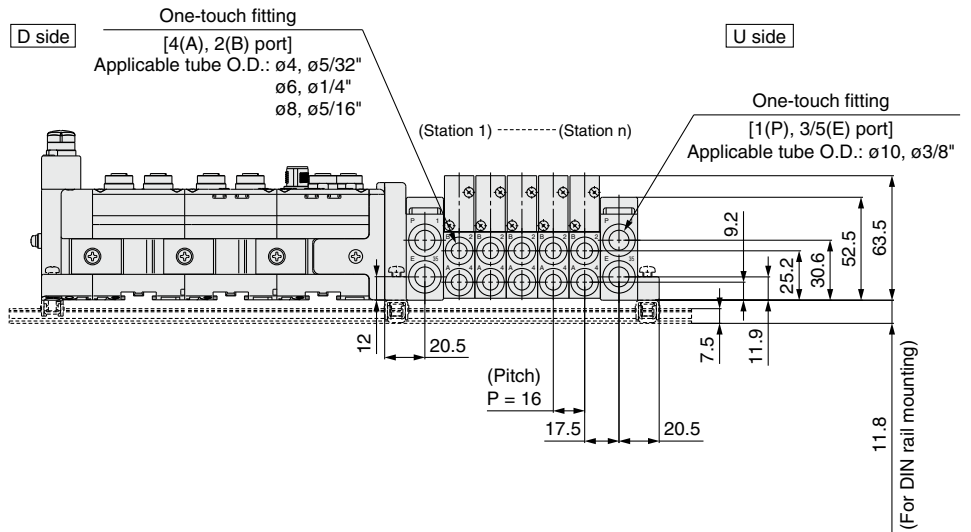
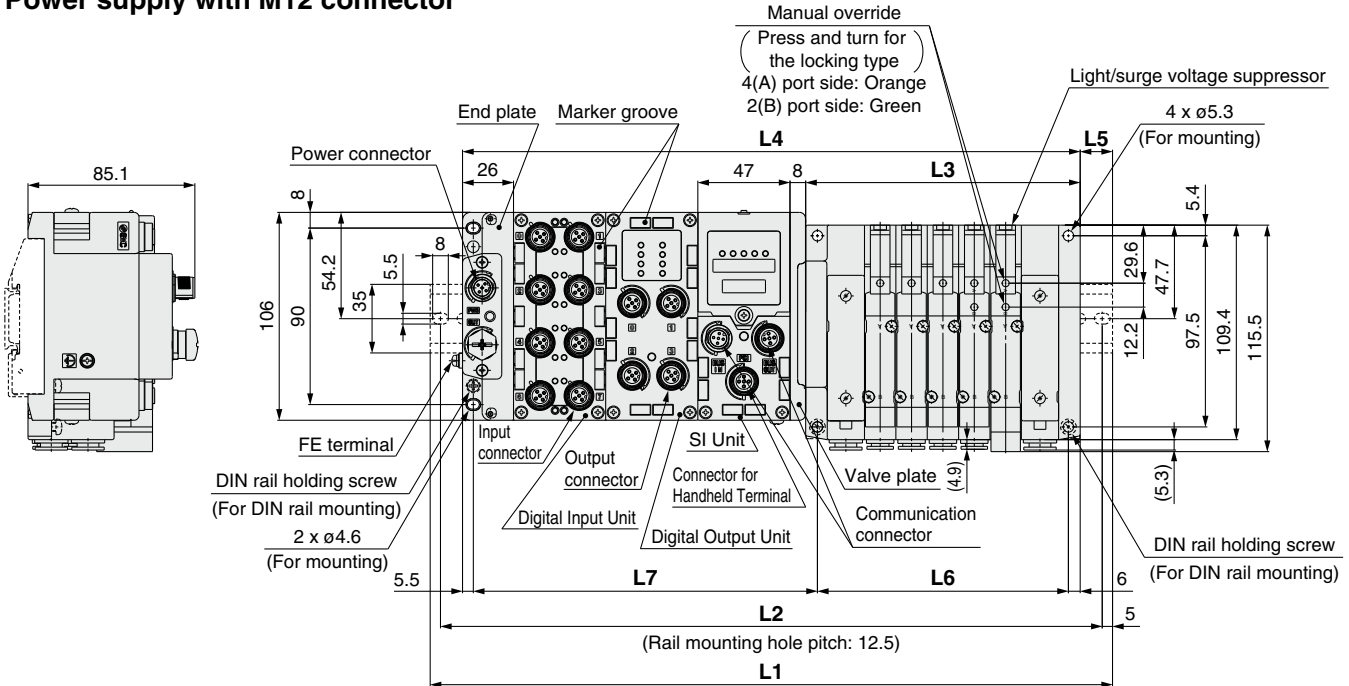

$L2 = L1 - 10.5$
 $L3 = 16 \times n1 + 60$
 $L4 = L3 + 81 + 47 \times n2$
 $L5 = (L1 - L4)/2$
 $L6 = 16 \times n1 + 48$
 $L7 = 47 \times n2 + 81.5$

n1: Valve stations
n2: I/O Unit stations

L1: DIN Rail Overall Length

I/O Unit stations (n2) \ Valve stations (n1)	2	3	4	5	6	7	8	9	10	11	12	13	14	15	16	17	18	19	20
0	198	223	235.5	248	260.5	285.5	298	310.5	335.5	348	360.5	373	398	410.5	423	448	460.5	473	485.5
1	248	260.5	285.5	298	310.5	335.5	348	360.5	373	398	410.5	423	435.5	460.5	473	485.5	510.5	523	535.5
2	298	310.5	323	348	360.5	373	398	410.5	423	435.5	460.5	473	485.5	510.5	523	535.5	548	573	585.5
3	348	360.5	373	385.5	410.5	423	435.5	460.5	473	485.5	498	523	535.5	548	573	585.5	598	610.5	635.5
4	385.5	410.5	423	435.5	460.5	473	485.5	498	523	535.5	548	560.5	585.5	598	610.5	635.5	648	660.5	673
5	435.5	448	473	485.5	498	523	535.5	548	560.5	585.5	598	610.5	635.5	648	660.5	673	698	710.5	723
6	485.5	498	510.5	535.5	548	560.5	585.5	598	610.5	623	648	660.5	673	698	710.5	723	735.5	760.5	773
7	535.5	548	560.5	585.5	598	610.5	623	648	660.5	673	685.5	710.5	723	735.5	760.5	773	785.5	798	823
8	573	598	610.5	623	648	660.5	673	685.5	710.5	723	735.5	760.5	773	785.5	798	823	835.5	848	860.5
9	623	635.5	660.5	673	685.5	710.5	723	735.5	748	773	785.5	798	823	835.5	848	860.5	885.5	898	910.5

Dimensions

Series SV2000

Power supply with 7/8 inch connector

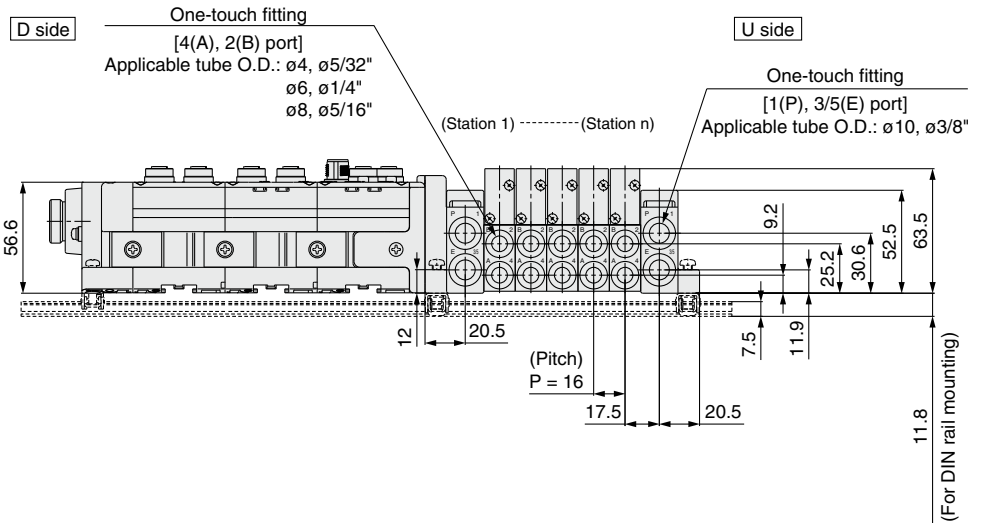
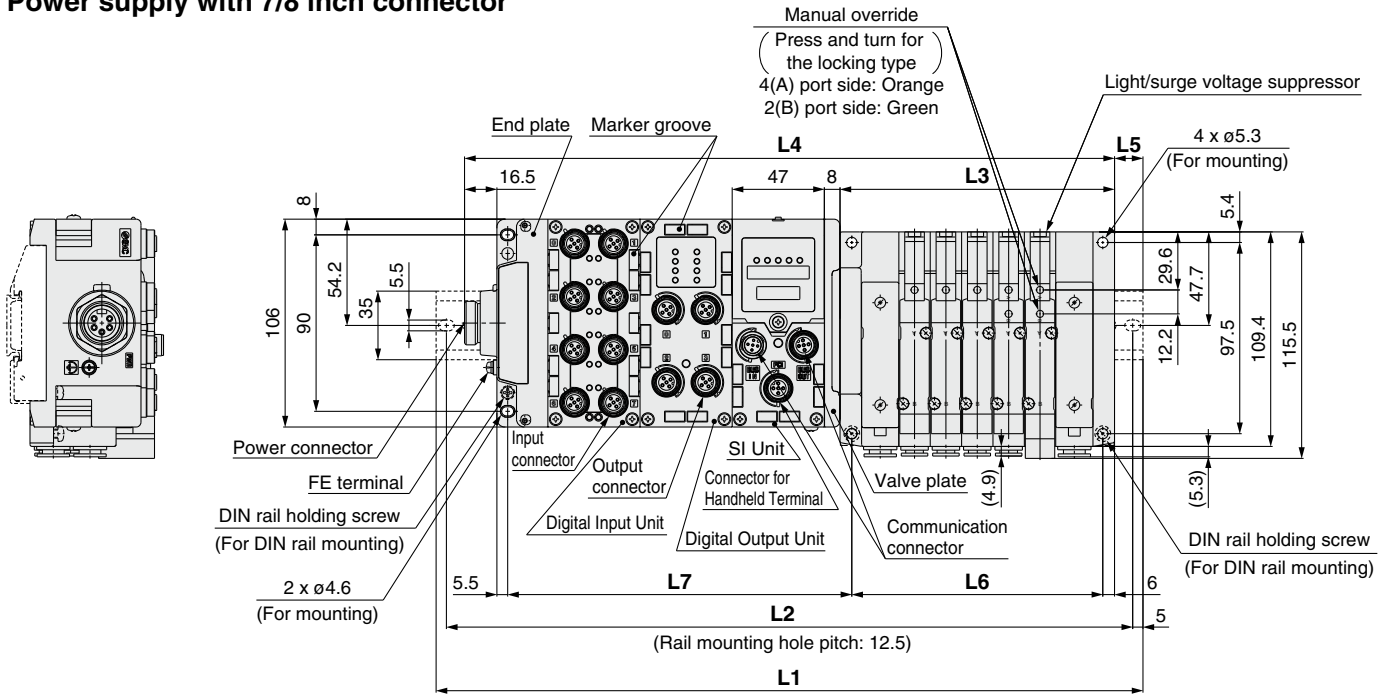

$L2 = L1 - 10.5$
 $L3 = 16 \times n1 + 60$
 $L4 = L3 + 97.5 + 47 \times n2$
 $L5 = (L1 - L4)/2$
 $L6 = 16 \times n1 + 48$
 $L7 = 47 \times n2 + 81.5$

n1: Valve stations
n2: I/O Unit stations

L1: DIN Rail Overall Length

Valve stations (n1) I/O Unit stations (n2)	[mm]																			
	2	3	4	5	6	7	8	9	10	11	12	13	14	15	16	17	18	19	20	
0	223	235.5	248	273	285.5	298	310.5	335.5	348	360.5	373	398	410.5	423	448	460.5	473	485.5	510.5	
1	260.5	285.5	298	310.5	335.5	348	360.5	373	398	410.5	423	448	460.5	473	485.5	510.5	523	535.5	548	
2	310.5	323	348	360.5	373	398	410.5	423	435.5	460.5	473	485.5	510.5	523	535.5	548	573	585.5	598	
3	360.5	373	398	410.5	423	435.5	460.5	473	485.5	498	523	535.5	548	573	585.5	598	610.5	635.5	648	
4	410.5	423	435.5	460.5	473	485.5	498	523	535.5	548	573	585.5	598	610.5	635.5	648	660.5	673	698	
5	448	473	485.5	498	523	535.5	548	560.5	585.5	598	610.5	635.5	648	660.5	673	698	710.5	723	748	
6	498	523	535.5	548	560.5	585.5	598	610.5	623	648	660.5	673	698	710.5	723	735.5	760.5	773	785.5	
7	548	560.5	585.5	598	610.5	623	648	660.5	673	698	710.5	723	735.5	760.5	773	785.5	798	823	835.5	
8	598	610.5	623	648	660.5	673	685.5	710.5	723	735.5	760.5	773	785.5	798	823	835.5	848	873	885.5	
9	648	660.5	673	685.5	710.5	723	735.5	748	773	785.5	798	823	835.5	848	860.5	885.5	898	910.5	935.5	

Series EX600

Series SY

Series SV

Series S0700

Series VQC

Series SV1000/2000/3000

Series **SV3000**

Dimensions

Power supply with M12 connector

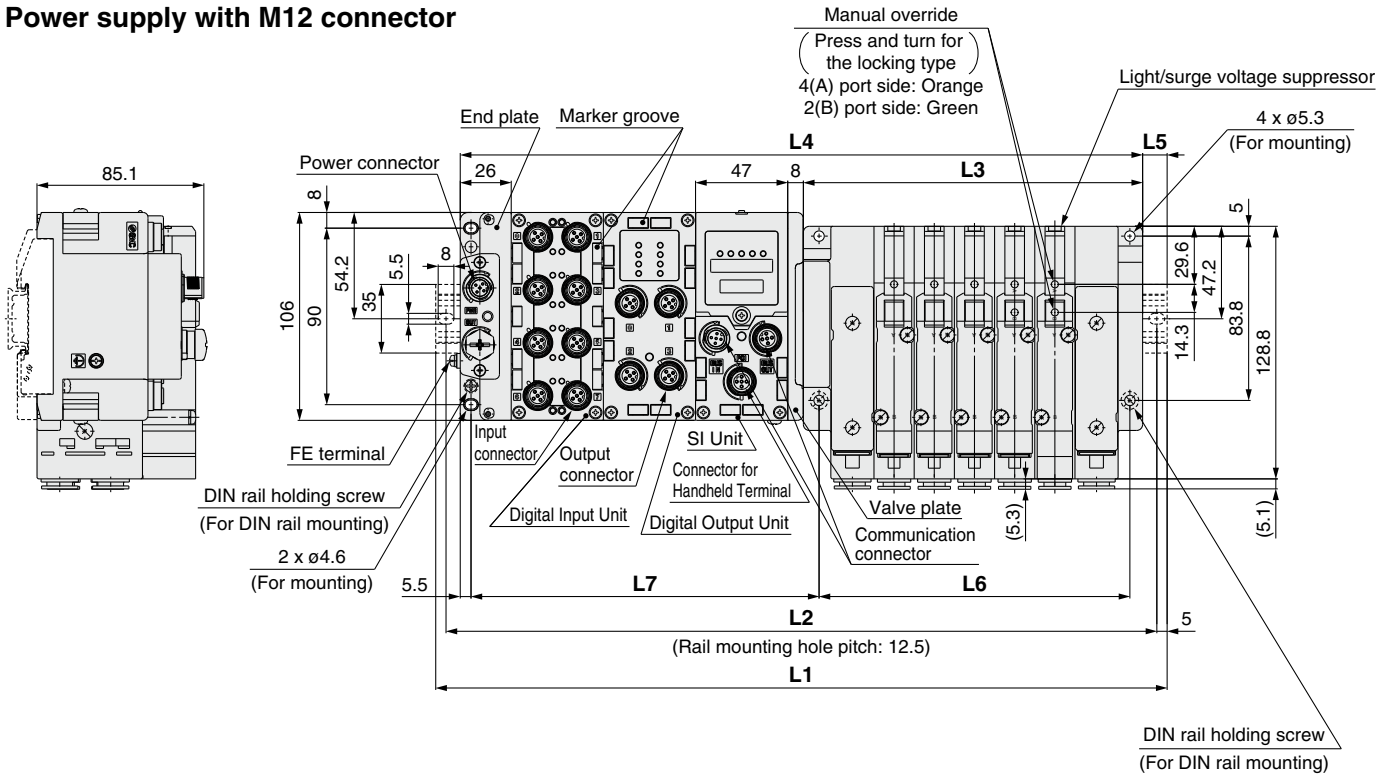

$$\begin{aligned}
 L2 &= L1 - 10.5 \\
 L3 &= 20.5 \times n1 + 70.5 \\
 L4 &= L3 + 81 + 47 \times n2 \\
 L5 &= (L1 - L4)/2 \\
 L6 &= 20.5 \times n1 + 56 \\
 L7 &= 47 \times n2 + 83.5
 \end{aligned}$$

n1: Valve stations
n2: I/O Unit stations

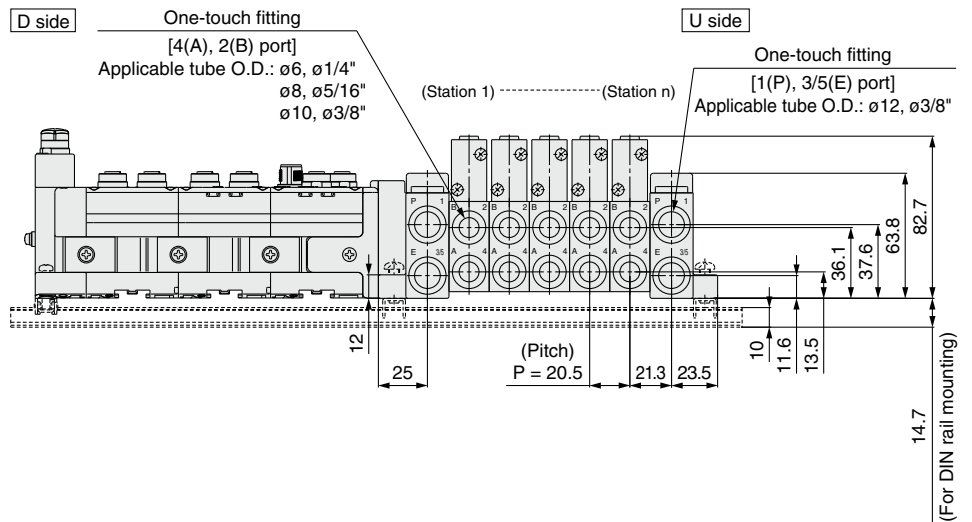

L1: DIN Rail Overall Length

Valve stations (n1) I/O Unit stations (n2)	[mm]																			
	2	3	4	5	6	7	8	9	10	11	12	13	14	15	16	17	18	19	20	
0	223	248	260.5	285.5	298	323	348	360.5	385.5	410.5	423	448	473	485.5	510.5	535.5	548	573	585.5	
1	273	285.5	310.5	335.5	348	373	398	410.5	435.5	448	473	498	510.5	535.5	560.5	573	598	623	635.5	
2	310.5	335.5	360.5	373	398	423	435.5	460.5	485.5	498	523	535.5	560.5	585.5	598	623	648	660.5	685.5	
3	360.5	385.5	398	423	448	460.5	485.5	510.5	523	548	573	585.5	610.5	635.5	648	673	685.5	710.5	735.5	
4	410.5	435.5	448	473	498	510.5	535.5	548	573	598	610.5	635.5	660.5	673	698	723	735.5	760.5	773	
5	460.5	473	498	523	535.5	560.5	585.5	598	623	635.5	660.5	685.5	698	723	748	760.5	785.5	810.5	823	
6	498	523	548	560.5	585.5	610.5	623	648	673	685.5	710.5	735.5	748	773	785.5	810.5	835.5	848	873	
7	548	573	598	610.5	635.5	648	673	698	710.5	735.5	760.5	773	798	823	835.5	860.5	873	898	923	
8	598	623	635.5	660.5	685.5	698	723	735.5	760.5	785.5	798	823	848	860.5	885.5	910.5	923	948	973	
9	648	660.5	685.5	710.5	723	748	773	785.5	810.5	835.5	848	873	885.5	910.5	935.5	948	973	—	—	

Dimensions

Power supply with 7/8 inch connector

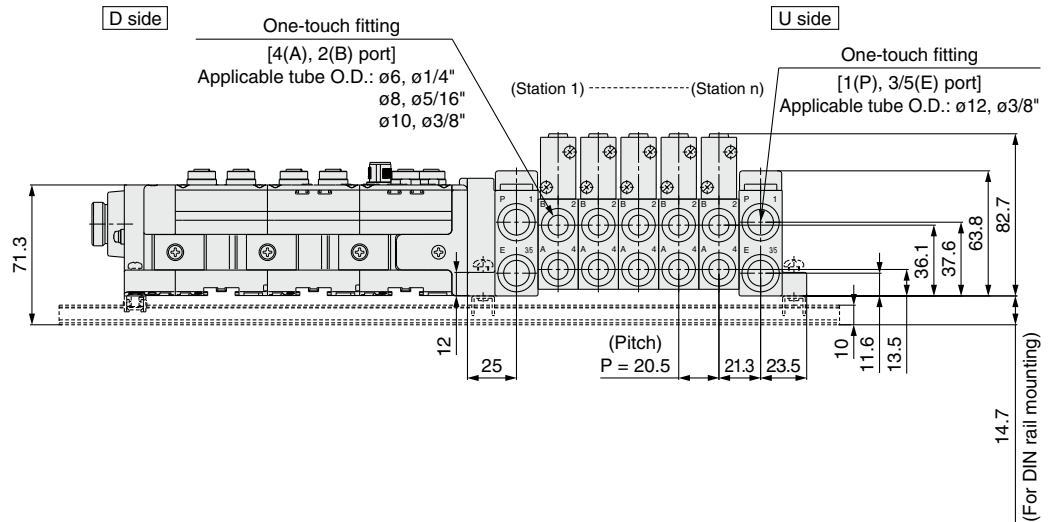
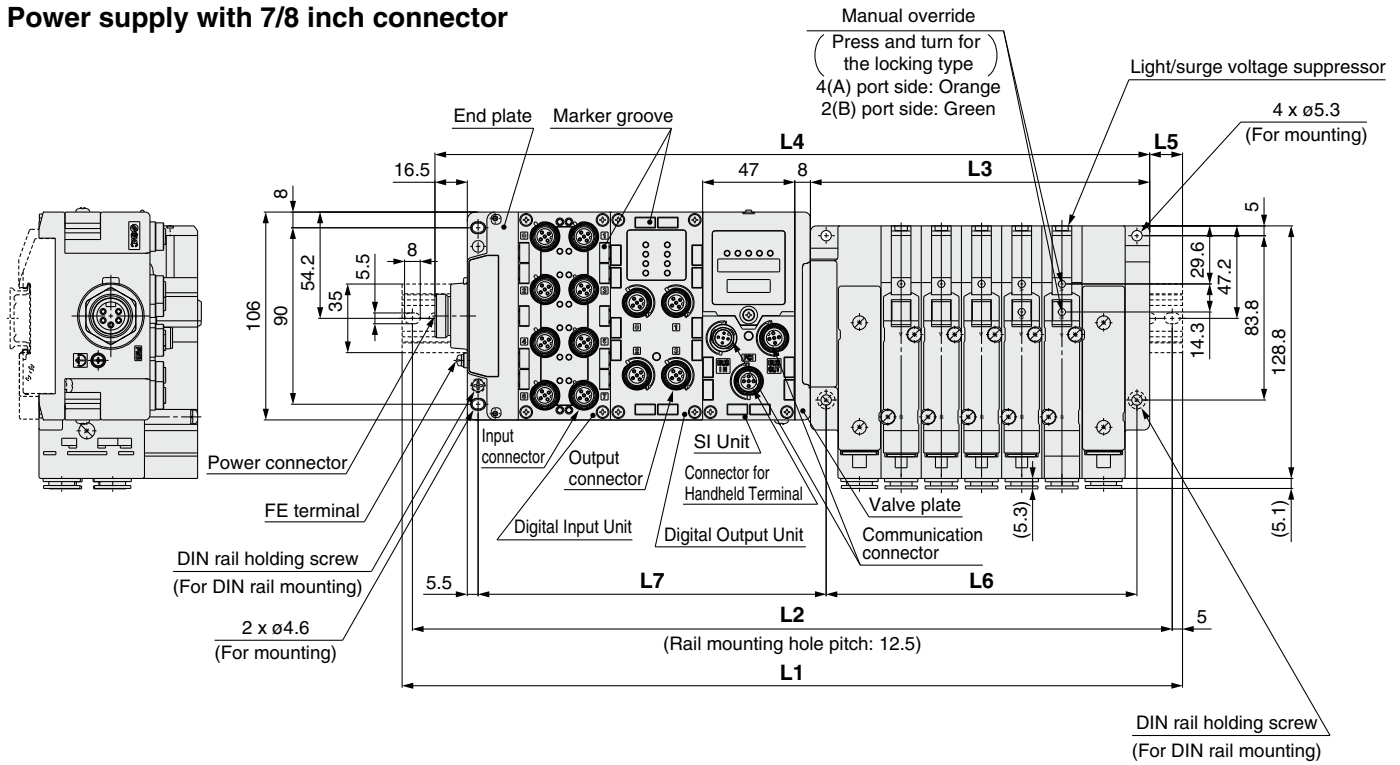

$L2 = L1 - 10.5$
 $L3 = 20.5 \times n1 + 70.5$
 $L4 = L3 + 97.5 + 47 \times n2$
 $L5 = (L1 - L4)/2$
 $L6 = 20.5 \times n1 + 56$
 $L7 = 47 \times n2 + 83.5$

n1: Valve stations
n2: I/O Unit stations

L1: DIN Rail Overall Length

I/O Unit stations (n2) \ Valve stations (n1)	[mm]																			
	2	3	4	5	6	7	8	9	10	11	12	13	14	15	16	17	18	19	20	
0	235.5	260.5	285.5	298	323	335.5	360.5	385.5	398	423	448	460.5	485.5	510.5	523	548	560.5	585.5	610.5	
1	285.5	310.5	323	348	373	385.5	410.5	423	448	473	485.5	510.5	535.5	548	573	598	610.5	635.5	660.5	
2	335.5	348	373	398	410.5	435.5	460.5	473	498	523	535.5	560.5	573	598	623	635.5	660.5	685.5	698	
3	385.5	398	423	435.5	460.5	485.5	498	523	548	560.5	585.5	610.5	623	648	660.5	685.5	710.5	723	748	
4	423	448	473	485.5	510.5	523	548	573	585.5	610.5	635.5	648	673	698	710.5	735.5	760.5	773	798	
5	473	498	510.5	535.5	560.5	573	598	623	635.5	660.5	673	698	723	735.5	760.5	785.5	798	823	848	
6	523	535.5	560.5	585.5	598	623	648	660.5	685.5	710.5	723	748	760.5	785.5	810.5	823	848	873	885.5	
7	573	585.5	610.5	623	648	673	685.5	710.5	735.5	748	773	798	810.5	835.5	860.5	873	898	910.5	935.5	
8	610.5	635.5	660.5	673	698	723	735.5	760.5	773	798	823	835.5	860.5	885.5	898	923	948	960.5	985.5	
9	660.5	685.5	698	723	748	760.5	785.5	810.5	823	848	860.5	885.5	910.5	923	948	973	985.5	—	—	

EX600

5 Port Solenoid Valve

Series S0700

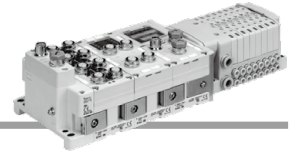

How to Order Manifold

SS0750 - 08 C4 SD6Q 2 N 1 - B

Valve stations

Symbol	Stations
01	1 station
⋮	⋮
24 ^{Note)}	24 stations

Note) The maximum number of stations depends on the wiring specifications.

Cylinder port size

Symbol	Port size	
C2	With ø2 One-touch fitting	Metric
C3	With ø3.2 One-touch fitting	
C4	With ø4 One-touch fitting	
CM	Mixed sizes and with port plug ^{Note)}	Inch
N1	With ø1/8" One-touch fitting	
N3	With ø5/32" One-touch fitting	
NM	Mixed sizes and with port plug ^{Note)}	

Note) Indicate the sizes on the manifold specification sheet in the case of "CM" and "NM".

SI Unit specifications

Symbol	Protocol	Stations	Max. number of stations for special wiring specification	Max. number of solenoids
SD60	Without SI Unit	1 to 16 stations	24 stations ^{Note)}	32
SD6Q	DeviceNet™			
SD6N	PROFIBUS DP			
SD6V	CC-Link			
SD6ZE	EtherNet/IP™ (1 port)			
SD6EA	EtherNet/IP™ (2 ports)			
SD6D	EtherCAT®			
SD6F	PROFINET			

- The maximum number of stations depends on the number of solenoids. Add the option symbol "K" when the combination of single wiring and double wiring is specified.
 - When "Without SI Unit" is specified, a valve plate which connects the manifold and SI Unit, is not mounted. Refer to page 65 for mounting method.
 - When "Without SI Unit" is specified, I/O Unit cannot be mounted.
- Note) Up to 24 stations due to the structure of the manifold. Note the maximum number of stations is 24 for single wiring, too.

Type of actuation	Single type	Double, dual 3-port type
Number of solenoids	1	2

End plate type

Nil	No end plate
2	Power supply with M12 connector (Max. supplied current 2 A)
3	Power supply with 7/8 inch connector (Max. supplied current 8 A)

- Without SI Unit, the symbol is nil.

Option

Symbol	Option
Nil	None
B ^{Note 2)}	With back pressure check valve (All stations)
D	With DIN rail (Rail length: Standard)
D0	Without DIN rail (with bracket)
D□ ^{Note 3)}	With DIN rail (Rail length specified, □: Stations)
K ^{Note 4)}	Special wiring specification (Except double wiring)
N	With name plate
R	External pilot
S	Built-in silencer

- Note 1) When multiple symbols are specified, indicate them alphabetically. Example) "-BKN"
- Note 2) When a back pressure check valve is used only for specified station, specify the back pressure check valve part number, and specify the station number to which the valve is mounted, on the manifold specification sheet.
- Note 3) Specified station number shall be longer than manifold station number.
- Note 4) When single wiring and double wiring are mixed, specify wiring type of each station on the manifold specification sheet.
- Note 5) When "Without SI Unit" is specified, "With DIN rail (D)" cannot be selected.

I/O Unit stations

Nil	None
1	1 station
⋮	⋮
9	9 stations

- Without SI Unit, the symbol is nil.
- SI Unit is not included in I/O Unit stations.
- When I/O Unit is selected, it is shipped separately and assembled by users. Refer to the attached operation manual for mounting method.

SI Unit output polarity

Nil	Positive common
N	Negative common

- Without SI Unit, the symbol is nil.

Refer to the catalog of each series for details on manifold solenoid valve specifications, Common Precautions and Specific Product Precautions.

How to Order Manifold Assembly

Example

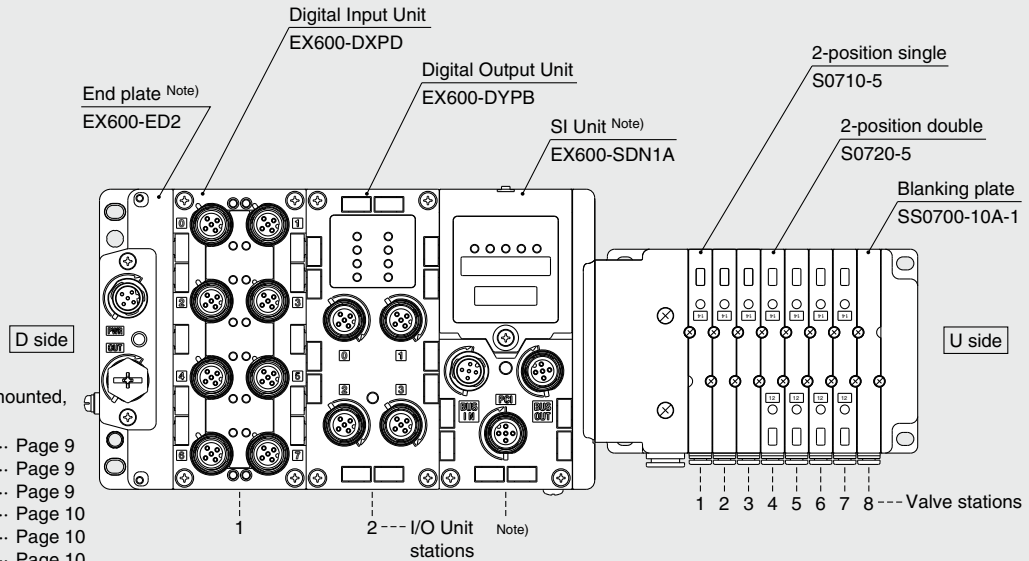

For the I/O Unit part number mounted, refer to the following pages.

- Digital Input Unit Page 9
- Digital Output Unit Page 9
- Digital Input/Output Unit Page 9
- Analog Input Unit Page 10
- Analog Output Unit Page 10
- Analog Input/Output Unit Page 10

- | | |
|-------------------------------|----------------------------------------|
| SS0750-08C4SD6Q2N2 1 set | Manifold base part number |
| * S0710-5 3 sets | Valve part number (Stations 1 to 3) |
| * S0720-5 4 sets | Valve part number (Stations 4 to 7) |
| * SS0700-10A-1 1 set | Blanking plate part number (Station 8) |
| * EX600-DXP 1 set | I/O Unit part number (Station 1) |
| * EX600-DYPB 1 set | I/O Unit part number (Station 2) |

Enter in order starting from the first station on the D side.
If the arrangement becomes complicated, specify on the manifold specification sheet.

Enter in order starting from the first station on the D side.

—The asterisk denotes the symbol for assembly.
Prefix it to the part numbers of the solenoid valve etc.

Note) Do not enter the SI Unit part number and the end plate part number together.

How to Order Valves

S07 1 0 [] - 5

Type of actuation	
1	<p>2-position single</p> <p>(A)4 2(B) (R1)5 13(R2) (P)</p>
2	<p>2-position double</p> <p>(A)4 2(B) (R1)5 13(R2) (P)</p>

A	<p>4-position dual 3-port valve (N.C. + N.C.) [Exhaust center]</p> <p>4(A) 2(B) 5(R1) 3(R2) 1(P)</p>
B	<p>4-position dual 3-port valve (N.O. + N.O.) [Pressure center]</p> <p>4(A) 2(B) 5(R1) 3(R2) 1(P)</p>
C	<p>4-position dual 3-port valve (N.C. + N.O.)</p> <p>4(A) 2(B) 5(R1) 3(R2) 1(P)</p>

• **Coil voltage**

5	24 VDC
---	--------

• **Function**

Symbol	Type
Nil	Standard
R	External pilot <small>Note)</small>

Note) Not applicable for dual 3-port valves

• **Base mounted plug-in**

Series S0700

Dimensions

Power supply with M12 connector

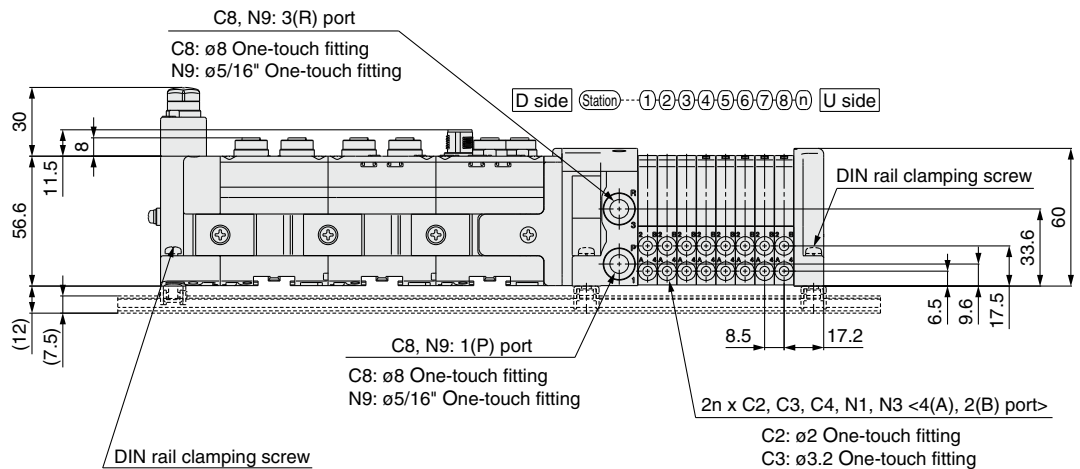
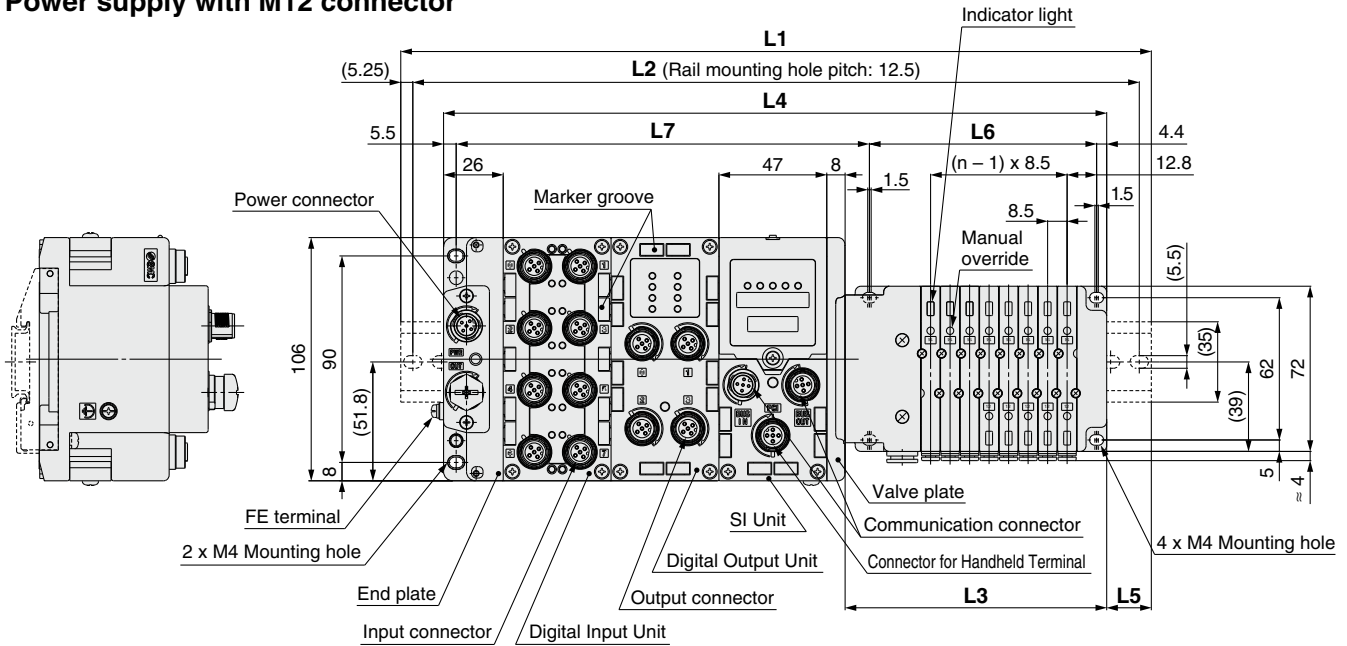

$$\begin{aligned}
 L2 &= L1 - 10.5 \\
 L3 &= 8.5 \times n1 + 46 \\
 L4 &= L3 + 81 + 47 \times n2 \\
 L5 &= (L1 - L4) / 2 \\
 L6 &= 8.5 \times n1 + 31 \\
 L7 &= 47 \times n2 + 86.1
 \end{aligned}$$

n1: Valve stations
n2: I/O Unit stations

L1: DIN Rail Overall Length

I/O Unit stations (n2) \ Valve stations (n1)	Valve stations (n1)																							
	1	2	3	4	5	6	7	8	9	10	11	12	13	14	15	16	17	18	19	20	21	22	23	24
0	173	185.5	185.5	198	210.5	210.5	223	235.5	235.5	248	260.5	260.5	273	285.5	285.5	298	310.5	310.5	323	335.5	335.5	348	360.5	373
1	223	223	235.5	248	248	260.5	273	273	285.5	298	298	310.5	323	323	335.5	348	360.5	360.5	373	385.5	385.5	398	410.5	410.5
2	260.5	273	285.5	285.5	298	310.5	310.5	323	335.5	348	348	360.5	373	373	385.5	398	398	410.5	423	423	435.5	448	448	460.5
3	310.5	323	335.5	335.5	348	360.5	360.5	373	385.5	385.5	398	410.5	410.5	423	435.5	448	448	460.5	460.5	473	485.5	485.5	498	510.5
4	360.5	373	373	385.5	398	398	410.5	423	423	435.5	448	448	460.5	473	473	485.5	498	498	510.5	523	535.5	535.5	548	560.5
5	410.5	410.5	423	435.5	435.5	448	460.5	460.5	473	485.5	485.5	498	510.5	523	523	535.5	548	548	560.5	573	573	585.5	598	598
6	448	460.5	473	473	485.5	498	510.5	510.5	523	535.5	535.5	548	560.5	560.5	573	585.5	585.5	598	610.5	610.5	623	635.5	635.5	648
7	498	510.5	523	523	535.5	548	548	560.5	573	573	585.5	598	598	610.5	623	623	635.5	648	648	660.5	673	673	685.5	698
8	548	560.5	560.5	573	585.5	585.5	598	610.5	610.5	623	635.5	635.5	648	660.5	660.5	673	685.5	698	698	710.5	723	723	735.5	748
9	598	598	610.5	623	623	635.5	648	648	660.5	673	685.5	685.5	698	710.5	710.5	723	735.5	735.5	748	760.5	760.5	773	785.5	785.5

Dimensions

Power supply with 7/8 inch connector

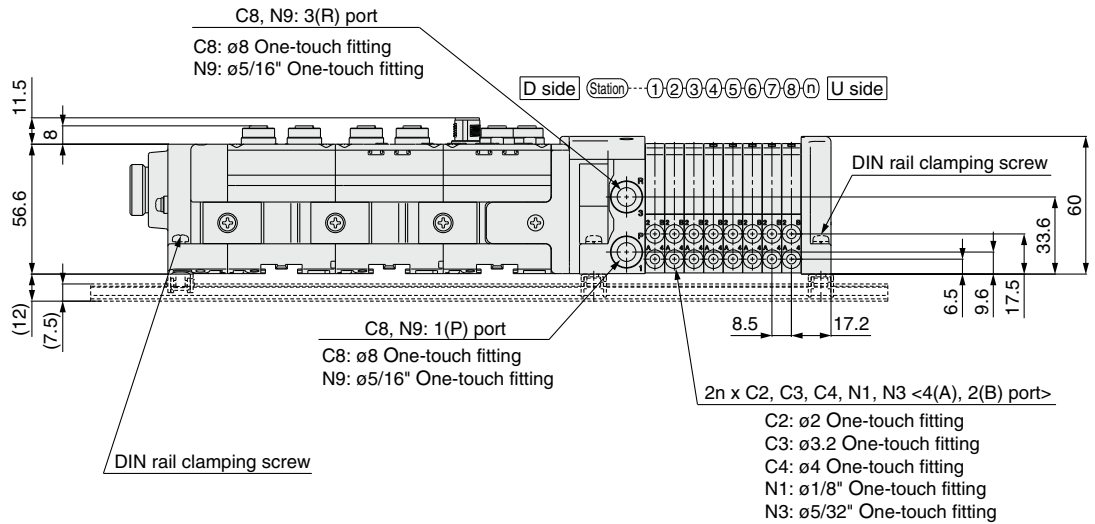
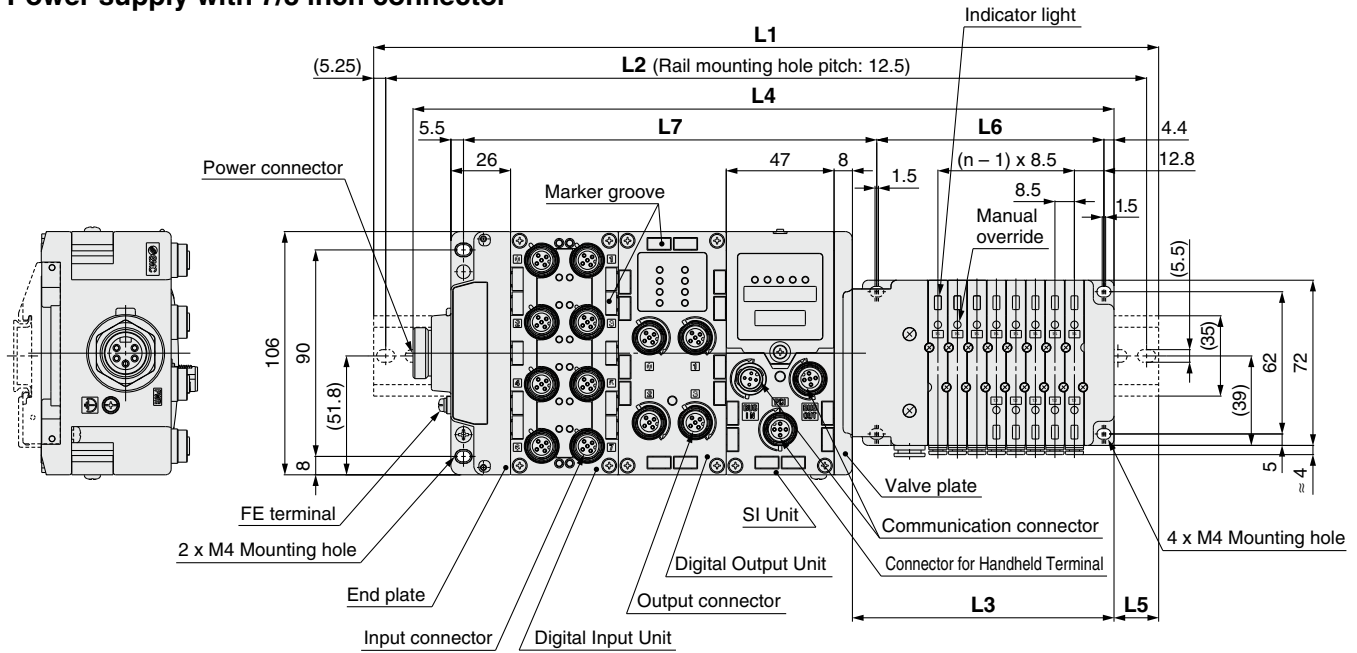

$L2 = L1 - 10.5$
 $L3 = 8.5 \times n1 + 46$
 $L4 = L3 + 97.5 + 47 \times n2$
 $L5 = (L1 - L4) / 2$
 $L6 = 8.5 \times n1 + 31$
 $L7 = 47 \times n2 + 86.1$

n1: Valve stations
n2: I/O Unit stations

L1: DIN Rail Overall Length

I/O Unit stations (n2) \ Valve stations (n1)	Valve stations (n1)																							
	1	2	3	4	5	6	7	8	9	10	11	12	13	14	15	16	17	18	19	20	21	22	23	24
0	185.5	198	210.5	210.5	223	235.5	235.5	248	260.5	260.5	273	285.5	285.5	298	310.5	310.5	323	335.5	335.5	348	360.5	360.5	373	385.5
1	235.5	248	248	260.5	273	273	285.5	298	298	310.5	323	323	335.5	348	348	360.5	373	385.5	385.5	398	410.5	410.5	423	435.5
2	285.5	285.5	298	310.5	310.5	323	335.5	335.5	348	360.5	373	373	385.5	398	398	410.5	423	423	435.5	448	448	460.5	473	473
3	323	335.5	348	360.5	360.5	373	385.5	385.5	398	410.5	410.5	423	435.5	435.5	448	460.5	460.5	473	485.5	485.5	498	510.5	510.5	523
4	373	385.5	398	398	410.5	423	423	435.5	448	448	460.5	473	473	485.5	498	498	498	510.5	523	523	535.5	548	560.5	573
5	423	435.5	435.5	448	460.5	460.5	473	485.5	485.5	498	510.5	510.5	523	535.5	548	548	560.5	573	573	585.5	598	598	610.5	623
6	473	473	485.5	498	498	510.5	523	535.5	535.5	548	560.5	560.5	573	585.5	585.5	598	610.5	610.5	623	635.5	635.5	648	660.5	660.5
7	523	523	535.5	548	548	560.5	573	573	585.5	598	598	610.5	623	623	635.5	648	648	660.5	673	673	685.5	698	698	710.5
8	560.5	573	585.5	585.5	598	610.5	610.5	623	635.5	635.5	648	660.5	660.5	673	685.5	685.5	698	710.5	723	723	735.5	748	748	760.5
9	610.5	623	623	635.5	648	648	660.5	673	673	685.5	698	710.5	710.5	723	735.5	735.5	748	760.5	760.5	773	785.5	785.5	798	810.5

EX600

5 Port Solenoid Valve

Series VQC1000

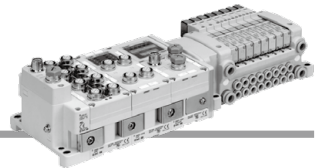

How to Order Manifold

VV5QC 1 1 - 08 C6 SD6Q 2 N 1 -

Series VQC1000
Base mounted plug-in

Valve stations

Symbol	Stations
01	1 station
⋮	⋮
24 ^{Note)}	24 stations

Note) The maximum number of stations depends on the wiring specifications.

Cylinder port size

C3	With ø3.2 One-touch fitting
C4	With ø4 One-touch fitting
C6	With ø6 One-touch fitting
M5	M5 thread
CM	Mixed sizes and with port plug
L3	Top ported elbow with ø3.2 One-touch fitting
L4	Top ported elbow with ø4 One-touch fitting
L6	Top ported elbow with ø6 One-touch fitting
L5	M5 thread
B3	Bottom ported elbow with ø3.2 One-touch fitting
B4	Bottom ported elbow with ø4 One-touch fitting
B6	Bottom ported elbow with ø6 One-touch fitting
B5	M5 thread
LM	Mixed port sizes of elbow piping

Note 1) Indicate the sizes on the manifold specification sheet in the case of "CM" and "LM".

Note 2) Symbols for inch size are as follows.

- N1: ø1/8" • N7: ø1/4"
- N3: ø5/32" • NM: Mixed sizes

The top ported elbow is LN□ and the bottom ported elbow is BN□. For NM, specify it on the manifold specification sheet.

SI Unit specifications

Symbol	Protocol	Stations	Max. number of stations for special wiring specification	Max. number of solenoids
SD60	Without SI Unit	1 to 12 stations	24 stations	24
SD6Q	DeviceNet™			
SD6N	PROFIBUS DP			
SD6V	CC-Link			
SD6ZE	EtherNet/IP™ (1 port)			
SD6EA	EtherNet/IP™ (2 ports)			
SD6D	EtherCAT®			
SD6F	PROFINET			

Note) The maximum number of stations depends on the number of solenoids.

Add the option symbol "K" when the combination of single wiring and double wiring is specified.

- When "Without SI Unit" is specified, I/O Unit cannot be mounted.
- When "Without SI Unit" is specified, a valve plate which connects the manifold and SI Unit, is not mounted. Refer to page 65 for mounting method.

Refer to the catalog of each series for details on manifold solenoid valve specifications, Common Precautions and Specific Product Precautions.

Option

Nil	None
B ^{Note 2)}	With back pressure check valve (All stations)
D	With DIN rail (Rail length: Standard)
D0	Without DIN rail (with bracket)
D □ ^{Note 3)}	With DIN rail (Rail length specified, □: Stations)
K ^{Note 4)}	Special wiring specification (Except double wiring)
N	With name plate
R ^{Note 5)}	External pilot
S ^{Note 6)}	Built-in silencer, Direct exhaust

Note 1) When multiple symbols are specified, indicate them alphabetically. Example) "-BRS"

Note 2) When a back pressure check valve is used only for specified station, specify the back pressure check valve part number, and specify the station number to which the valve is mounted, on the manifold specification sheet.

Note 3) D□: When the length of the DIN rail is specific (□ is the number of stations). Example) "-D08"
In this case, the valves will be mounted on the DIN rail for 8 stations, regardless of the number of manifold stations. Specified station number shall be longer than manifold station number.

Note 4) When single wiring and double wiring are mixed, specify wiring type of each station on the manifold specification sheet.

Note 5) When external pilot type is selected, also specify external pilot type for valves.

Note 6) Built-in silencer type does not satisfy IP67.

Note 7) When specification change from no DIN rail type to DIN rail mounting type, please consult SMC.

Note 8) When "Without SI Unit" is specified, "With DIN rail (D)" cannot be selected.

Note 9) DIN rail is not attached (but shipped together) on the manifold in the case of with DIN rail. Refer to the **WEB catalog** for mounting method.

I/O Unit stations

Nil	None
1	1 station
⋮	⋮
9	9 stations

Note 1) Without SI Unit, the symbol is nil.

Note 2) SI Unit is not included in I/O Unit stations.

Note 3) When I/O Unit is selected, it is shipped separately and assembled by users.

Refer to the attached operation manual for mounting method.

Note 4) Refer to page 64 for details on enclosure.

SI Unit output polarity

Nil	Positive common
N	Negative common

Note) Without SI Unit, the symbol is nil.

End plate type

Nil	No end plate
2	Power supply with M12 connector (Max. supplied current 2 A)
3	Power supply with 7/8 inch connector (Max. supplied current 8 A)

Note) Without SI Unit, the symbol is nil.

How to Order Manifold Assembly

Example (VV5QC11)

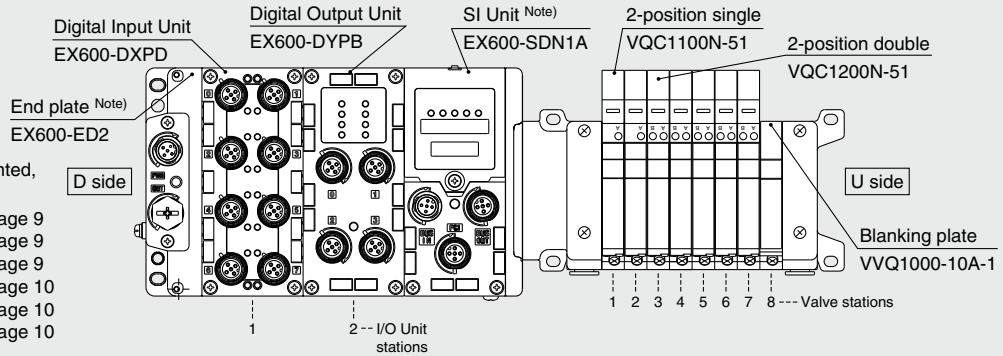

For the I/O Unit part number mounted, refer to the following pages.

- Digital Input Unit Page 9
- Digital Output Unit Page 9
- Digital Input/Output Unit Page 9
- Analog Input Unit Page 10
- Analog Output Unit Page 10
- Analog Input/Output Unit Page 10

- VV5QC11-08C6SD6Q2N2** 1 set **Manifold base part number**
- * **VQC1100N-51** 2 sets **Valve part number (Stations 1 to 2)**
 - * **VQC1200N-51** 5 sets **Valve part number (Stations 3 to 7)**
 - * **VVQ1000-10A-1** 1 set **Blanking plate part number (Station 8)**
 - * **EX600-DXPB** 1 set **I/O Unit part number (Station 1)**
 - * **EX600-DYPB** 1 set **I/O Unit part number (Station 2)**

The asterisk denotes the symbol for assembly. Prefix it to the part numbers of the solenoid valve etc.

Enter in order starting from the first station on the D side. If the arrangement becomes complicated, specify on the manifold specification sheet.

Enter in order starting from the first station on the D side. If the arrangement becomes complicated, specify on the manifold specification sheet.

Note) Do not enter the SI Unit part number and the end plate part number together.

How to Order Valves

VQC 1 1 0 0 - 5 1

Series VQC1000

Type of actuation

1	2-position single (A)4 2(B) (R1)5 1 3(R2) (P)	Note) A	4-position dual 3-port valve (A) 4(A) 2(B) 5(R1) 1(P) 3(R2) N.C. N.C.
	2-position double (Metal) (A)4 2(B) (R1)5 1 3(R2) (P)		Note) B
2	2-position double (Rubber) (A)4 2(B) (R1)5 1 3(R2) (P)	Note) C	4-position dual 3-port valve (C) 4(A) 2(B) 5(R1) 1(P) 3(R2) N.C. N.O.
	3-position closed center (A)4 2(B) (R1)5 1 3(R2) (P)		Note) Only rubber seal type
4	3-position exhaust center (A)4 2(B) (R1)5 1 3(R2) (P)		
5	3-position pressure center (A)4 2(B) (R1)5 1 3(R2) (P)		

Coil voltage

5 24 VDC

Function

Nil	Standard (0.4 W)
B	Quick response type (0.95 W)
K Note 2)	High pressure type (1.0 MPa, 0.95 W)
N Note 3)	Negative common
R Note 4)	External pilot

Note 1) When multiple symbols are specified, indicate them alphabetically. However, combination of "B" and "K" is not possible.

Note 2) Only metal seal type

Note 3) When negative common is specified for the SI Unit, select and mount a valve of negative common.

Note 4) Not applicable for dual 3-port valves

Seal type

0	Metal seal
1	Rubber seal

Manual override

Nil: Non-locking push type (Tool required)

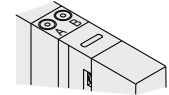

B: Locking type (Tool required)

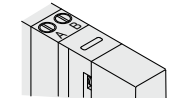

C: Locking type (Manual)

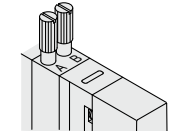

D: Slide locking type (Manual)

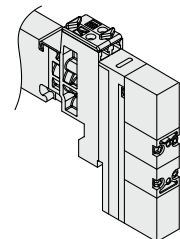

Series VQC1000

Dimensions

Power supply with M12 connector

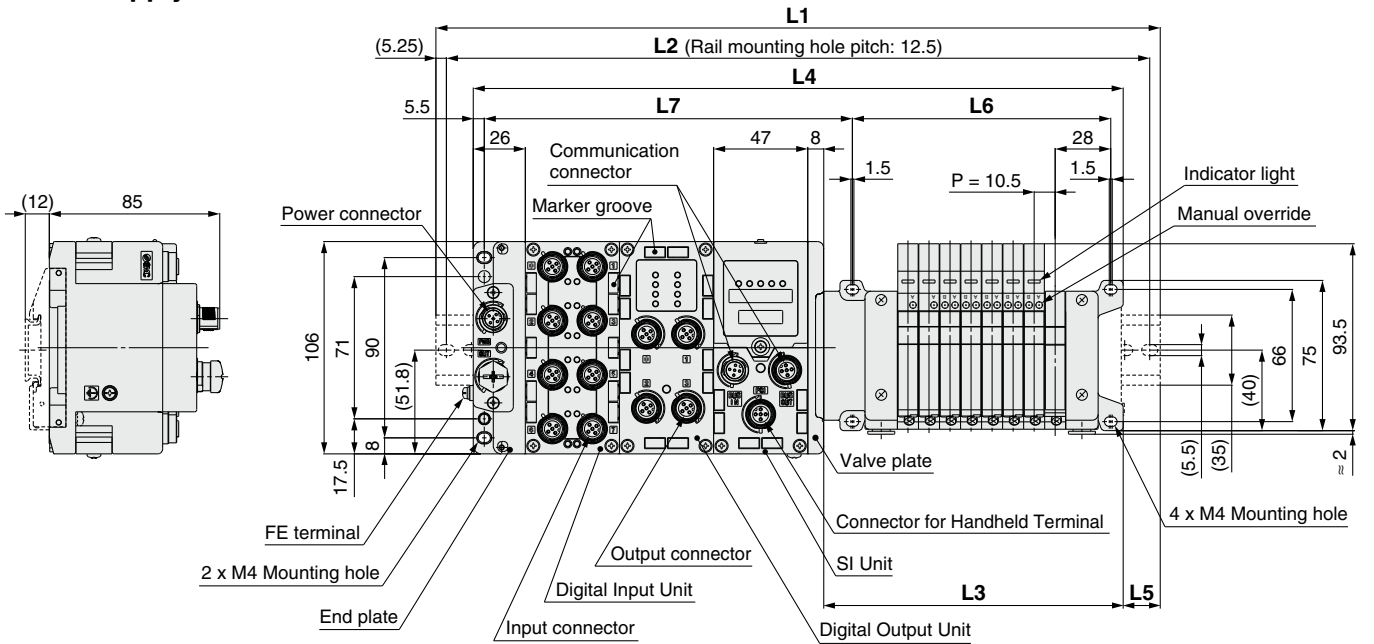

D side Station---(1)---(2)---(3)---(4)---(5)---(6)---(7)---(8)---(n) U side

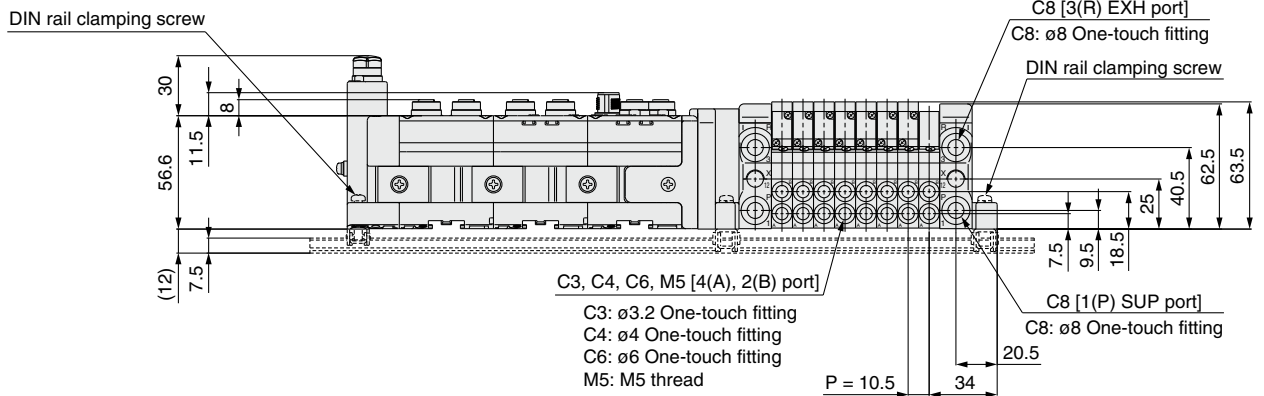

$$\begin{aligned}
 L2 &= L1 - 10.5 \\
 L3 &= 10.5 \times n1 + 65.5 \\
 L4 &= L3 + 81 + 47 \times n2 \\
 L5 &= (L1 - L4) / 2 \\
 L6 &= 10.5 \times n1 + 45 \\
 L7 &= 47 \times n2 + 89.8
 \end{aligned}$$

n1: Valve stations
n2: I/O Unit stations

L1: DIN Rail Overall Length

I/O Unit stations (n2) \ Valve stations (n1)	Valve stations (n1)																							
	1	2	3	4	5	6	7	8	9	10	11	12	13	14	15	16	17	18	19	20	21	22	23	24
0	198	198	210.5	223	235.5	248	260.5	260.5	273	285.5	298	310.5	323	335.5	335.5	348	360.5	373	385.5	398	398	410.5	423	435.5
1	235.5	248	260.5	273	285.5	298	298	310.5	323	335.5	348	360.5	360.5	373	385.5	398	410.5	423	423	435.5	448	460.5	473	485.5
2	285.5	298	310.5	323	323	335.5	348	360.5	373	385.5	398	398	410.5	423	435.5	448	460.5	460.5	473	485.5	498	510.5	523	523
3	335.5	348	360.5	360.5	373	385.5	398	410.5	423	423	435.5	448	460.5	473	485.5	485.5	498	510.5	523	535.5	548	560.5	560.5	573
4	385.5	385.5	398	410.5	423	435.5	448	460.5	460.5	473	485.5	498	510.5	523	523	535.5	548	560.5	573	585.5	585.5	598	610.5	623
5	423	435.5	448	460.5	473	485.5	485.5	498	510.5	523	535.5	548	548	560.5	573	585.5	598	610.5	623	623	635.5	648	660.5	673
6	473	485.5	498	510.5	523	523	535.5	548	560.5	573	585.5	585.5	598	610.5	623	635.5	648	648	660.5	673	685.5	698	710.5	710.5
7	523	535.5	548	548	560.5	573	585.5	598	610.5	610.5	623	635.5	648	660.5	673	685.5	685.5	698	710.5	723	735.5	748	748	760.5
8	573	585.5	585.5	598	610.5	623	635.5	648	648	660.5	673	685.5	698	710.5	710.5	723	735.5	748	760.5	773	773	785.5	798	810.5
9	610.5	623	635.5	648	660.5	673	673	685.5	698	710.5	723	735.5	748	748	760.5	773	785.5	798	810.5	810.5	823	835.5	848	860.5

Dimensions

Power supply with 7/8 inch connector

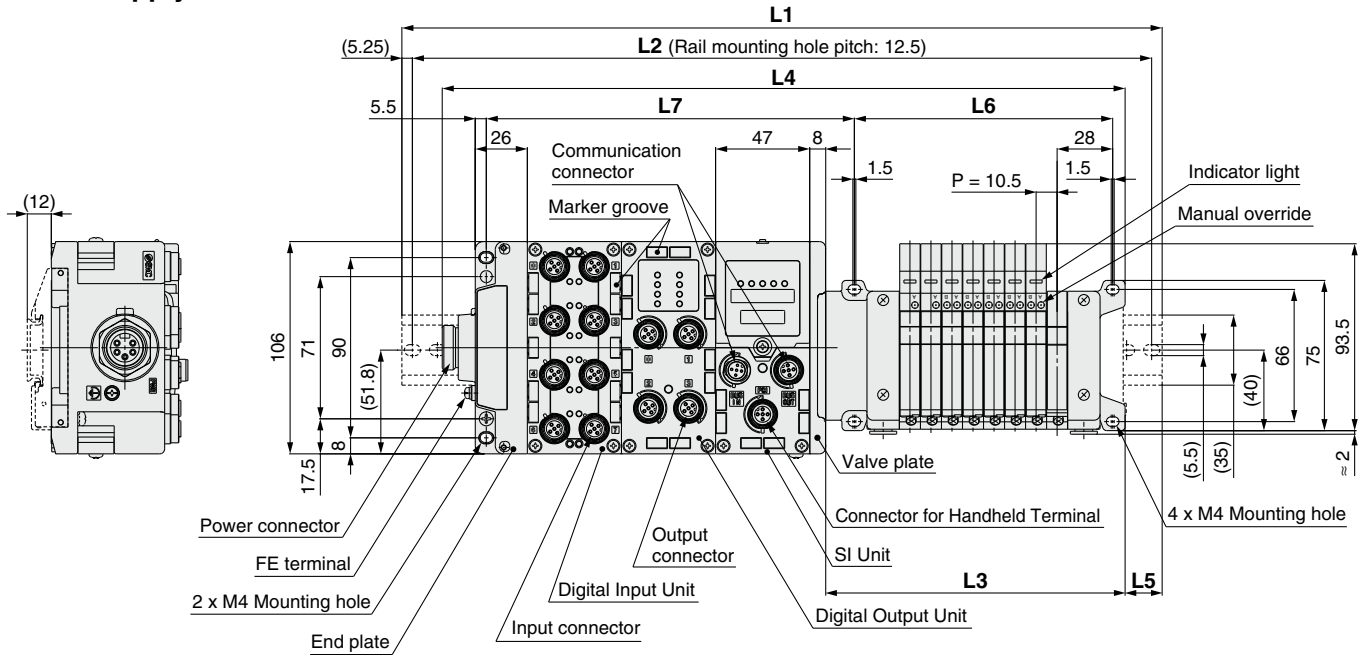

D side Station---1-2-3-4-5-6-7-8---n U side

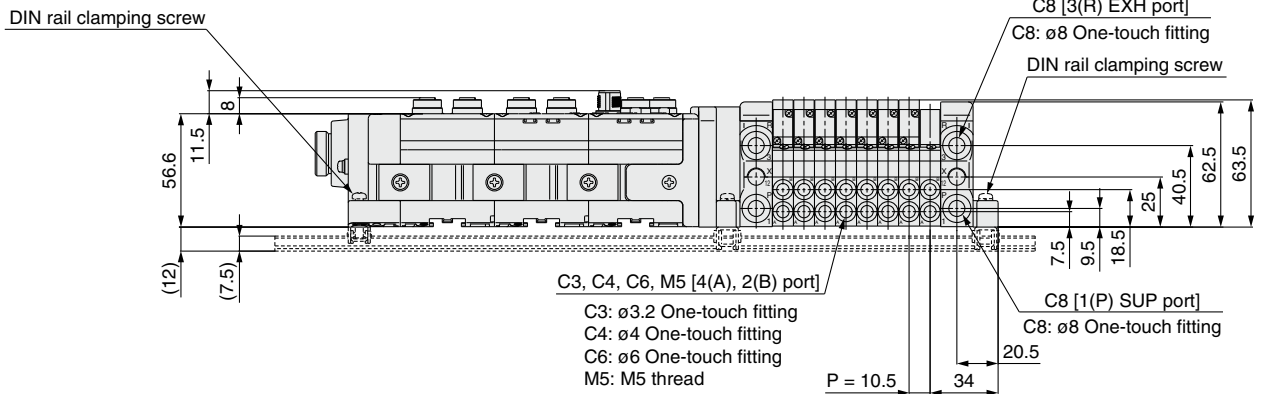

$$L2 = L1 - 10.5$$

$$L3 = 10.5 \times n1 + 65.5$$

$$L4 = L3 + 97.5 + 47 \times n2$$

$$L5 = (L1 - L4) / 2$$

$$L6 = 10.5 \times n1 + 45$$

$$L7 = 47 \times n2 + 89.8$$

n1: Valve stations
n2: I/O Unit stations

L1: DIN Rail Overall Length

I/O Unit stations (n2) \ Valve stations (n1)	Valve stations (n1)																							
	1	2	3	4	5	6	7	8	9	10	11	12	13	14	15	16	17	18	19	20	21	22	23	24
0	210.5	223	235.5	235.5	248	260.5	273	285.5	298	298	310.5	323	335.5	348	360.5	373	373	385.5	398	410.5	423	435.5	435.5	448
1	260.5	273	273	285.5	298	310.5	323	335.5	335.5	348	360.5	373	385.5	398	398	410.5	423	435.5	448	460.5	460.5	473	485.5	498
2	298	310.5	323	335.5	348	360.5	360.5	373	385.5	398	410.5	423	435.5	448	460.5	473	485.5	498	498	510.5	523	535.5	548	558
3	348	360.5	373	385.5	398	398	410.5	423	435.5	448	460.5	460.5	473	485.5	498	510.5	523	523	535.5	548	560.5	573	585.5	598
4	398	410.5	423	423	435.5	448	460.5	473	485.5	498	498	510.5	523	535.5	548	560.5	560.5	573	585.5	598	610.5	623	623	635.5
5	448	460.5	460.5	473	485.5	498	510.5	523	523	535.5	548	560.5	573	585.5	598	610.5	623	635.5	648	660.5	660.5	673	685.5	698
6	485.5	498	510.5	523	535.5	548	560.5	560.5	573	585.5	598	610.5	623	623	635.5	648	660.5	673	685.5	685.5	698	710.5	723	735.5
7	535.5	548	560.5	573	585.5	598	610.5	623	635.5	648	648	660.5	673	685.5	698	710.5	723	723	735.5	748	760.5	773	785.5	798
8	585.5	598	610.5	623	623	635.5	648	660.5	673	685.5	685.5	698	710.5	723	735.5	748	748	760.5	773	785.5	798	810.5	810.5	823
9	635.5	648	648	660.5	673	685.5	698	710.5	710.5	723	735.5	748	760.5	773	785.5	798	810.5	823	835.5	848	848	860.5	873	885.5

EX600

5 Port Solenoid Valve

Series VQC2000

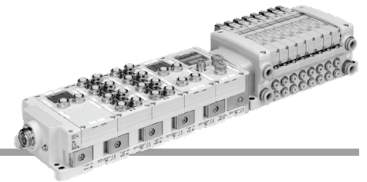

How to Order Manifold

VV5QC 2 1 - 08 C8 SD6Q 2 N 1 -

Series VQC2000
Base mounted plug-in

Symbol	Stations
01	1 station
⋮	⋮
24 ^{Note)}	24 stations

Note) The maximum number of stations depends on the wiring specifications.

Cylinder port size

C4	With ø4 One-touch fitting
C6	With ø6 One-touch fitting
C8	With ø8 One-touch fitting
CM	Mixed sizes and with port plug
L4	Top ported elbow with ø4 One-touch fitting
L6	Top ported elbow with ø6 One-touch fitting
L8	Top ported elbow with ø8 One-touch fitting
B4	Bottom ported elbow with ø4 One-touch fitting
B6	Bottom ported elbow with ø6 One-touch fitting
B8	Bottom ported elbow with ø8 One-touch fitting
LM	Mixed port sizes of elbow piping

Note 1) Indicate the sizes on the manifold specification sheet in the case of "CM" and "LM".

Note 2) Symbols for inch size are as follows.

- N3: ø5/32" • N9: ø5/16"
- N7: ø1/4" • NM: Mixed sizes

The top ported elbow is LN□ and the bottom ported elbow is BN□. For NM, specify it on the manifold specification sheet.

SI Unit specifications

Symbol	Protocol	Stations	Max. number of stations for special wiring specification	Max. number of solenoids
SD60	Without SI Unit	1 to 12 stations	24 stations	24
SD6Q	DeviceNet™			
SD6N	PROFIBUS DP			
SD6V	CC-Link			
SD6ZE	EtherNet/IP™ (1 port)			
SD6EA	EtherNet/IP™ (2 ports)			
SD6D	EtherCAT®			
SD6F	PROFINET			

Note) The maximum number of stations depends on the number of solenoids.

Add the option symbol "K" when the combination of single wiring and double wiring is specified.

- When "Without SI Unit" is specified, I/O Unit cannot be mounted.
- When "Without SI Unit" is specified, a valve plate which connects the manifold and SI Unit, is not mounted. Refer to back page 65 for mounting method.

End plate type

Nil	No end plate
2	Power supply with M12 connector (Max. supplied current 2 A)
3	Power supply with 7/8 inch connector (Max. supplied current 8 A)

Note) Without SI Unit, the symbol is nil.

Option

Nil	None
B ^{Note 2)}	With back pressure check valve (All stations)
D ^{Note 3)}	With DIN rail (Rail length: Standard)
DO	Without DIN rail (with bracket)
D□ ^{Note 4)}	With DIN rail (Rail length specified, □: Stations)
K ^{Note 5)}	Special wiring specification (Except double wiring)
N	With name plate
R ^{Note 6)}	External pilot
S ^{Note 7)}	Built-in silencer, Direct exhaust
T ^{Note 8)}	P and R ports included on both sides of the U side

Note 1) When multiple symbols are specified, indicate them alphabetically. Example) "-BRS"

Note 2) When a back pressure check valve is used only for specified station, specify the back pressure check valve part number, and specify the station number to which the valve is mounted, on the manifold specification sheet.

Note 3) When selecting the DIN rail mounting (with DIN rail) of the VQC2000 series with the end plate to a power supply 7/8 inch connector, 9 I/O Unit stations will result in a total of 23 valve stations. With 24 stations, the DIN rail mounting (with DIN rail) cannot be indicated, so please exercise caution. (Refer to "DIN Rail Overall Length" on page 58.)

Note 4) D□: When the length of the DIN rail is specific (□ is the number of stations). Example) "-D08"
In this case, the valves will be mounted on the DIN rail for 8 stations, regardless of the number of manifold stations. Specified station number shall be longer than manifold station number.

Note 5) When single wiring and double wiring are mixed, specify wiring type of each station on the manifold specification sheet.

Note 6) When external pilot type is selected, also specify external pilot type for valves.

Note 7) Built-in silencer type does not satisfy IP67.

Note 8) 2 ports for SUP and EXH are included on both sides of U side (cylinder port and coil side) with ø12 One-touch fittings.

Note 9) When specification change from no DIN rail type to DIN rail mounting type, please consult SMC.

Note 10) When "Without SI Unit" is specified, "With DIN rail (D)" cannot be selected.

Note 11) DIN rail is not attached (but shipped together) on the manifold in the case of with DIN rail. Refer to the **WEB catalog** for mounting method.

I/O Unit stations

Nil	None
1	1 station
⋮	⋮
9	9 stations

Note 1) Without SI Unit, the symbol is nil.

Note 2) SI Unit is not included in I/O Unit stations.

Note 3) When I/O Unit is selected, it is shipped separately and assembled by users. Refer to the attached operation manual for mounting method.

Note 4) Refer to page 64 for details on enclosure.

SI Unit output polarity

Nil	Positive common
N	Negative common

Note) Without SI Unit, the symbol is nil.

How to Order Valves

VQC 2 1 0 0 - 5 1

Series VQC2000

Manual override

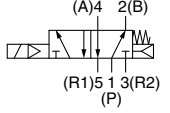
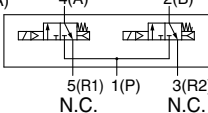
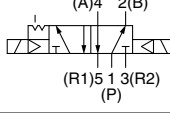
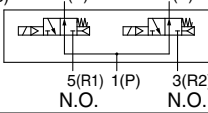
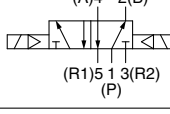
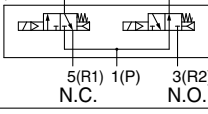
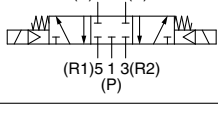
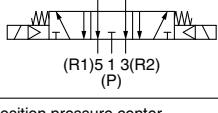
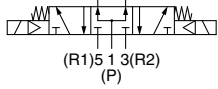
	Type of actuation					
1	2-position single  (A)4 2(B) (R1)5 1 3(R2) (P)	Note) A	4-position dual 3-port valve  (A) 4(A) 2(B) 5(R1) 1(P) 3(R2) N.C. N.C.			
2	2-position double (Metal)  (A)4 2(B) (R1)5 1 3(R2) (P)	Note) B	4-position dual 3-port valve  (B) 4(A) 2(B) 5(R1) 1(P) 3(R2) N.O. N.O.			
	2-position double (Rubber)  (A)4 2(B) (R1)5 1 3(R2) (P)	Note) C	4-position dual 3-port valve  (C) 4(A) 2(B) 5(R1) 1(P) 3(R2) N.C. N.O.			
3	3-position closed center  (A)4 2(B) (R1)5 1 3(R2) (P)	Note) Only rubber seal type				
4	3-position exhaust center  (A)4 2(B) (R1)5 1 3(R2) (P)					
5	3-position pressure center  (A)4 2(B) (R1)5 1 3(R2) (P)					

Nil: Non-locking push type (Tool required)

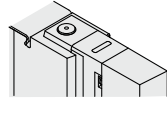

B: Locking type (Tool required)

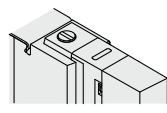

C: Locking type (Manual)

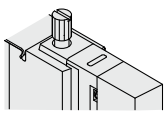

D: Slide locking type (Manual)

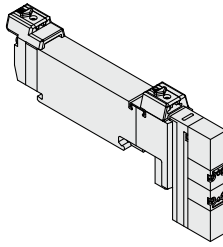

Seal type

0	Metal seal
1	Rubber seal

Function

Nil	Standard (0.4 W)
B	Quick response type (0.95 W)
K <small>Note 2)</small>	High pressure type (1.0 MPa, 0.95 W)
N <small>Note 3)</small>	Negative common
R <small>Note 4)</small>	External pilot

Note 1) When multiple symbols are specified, indicate them alphabetically. However, combination of "B" and "K" is not possible.

Note 2) Only metal seal type

Note 3) When negative common is specified for SI Unit, select and mount a valve of negative common.

Note 4) Not applicable for dual 3-port valves

Coil voltage

5	24 VDC
----------	--------

Refer to the catalog of each series for details on manifold solenoid valve specifications, Common Precautions and Specific Product Precautions.

Series EX600

Series SY

Series SV

Series S0700

Series VQC

Series VQC2000

Dimensions

Power supply with M12 connector

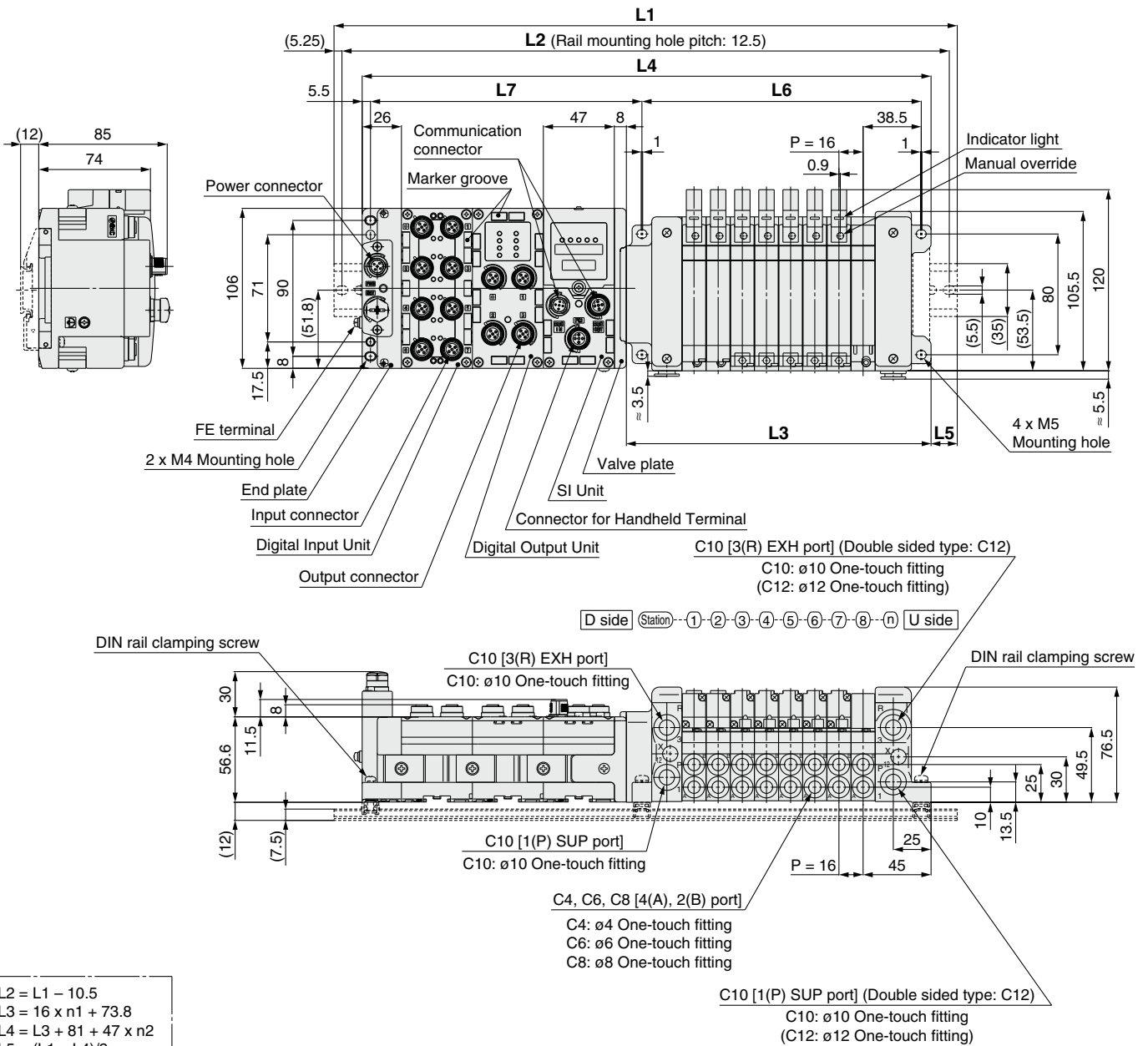

$L2 = L1 - 10.5$
 $L3 = 16 \times n1 + 73.8$
 $L4 = L3 + 81 + 47 \times n2$
 $L5 = (L1 - L4) / 2$
 $L6 = 16 \times n1 + 57$
 $L7 = 47 \times n2 + 85.8$

n1: Valve stations
 n2: I/O Unit stations

L1: DIN Rail Overall Length

I/O Unit stations (n2) \ Valve stations (n1)	Valve stations (n1)																							
	1	2	3	4	5	6	7	8	9	10	11	12	13	14	15	16	17	18	19	20	21	22	23	24
0	210.5	223	235.5	260.5	273	285.5	298	323	335.5	348	373	385.5	398	410.5	435.5	448	460.5	473	498	510.5	523	548	560.5	573
1	248	273	285.5	298	323	335.5	348	360.5	385.5	398	410.5	435.5	448	460.5	473	498	510.5	523	548	560.5	573	585.5	610.5	623
2	298	323	335.5	348	360.5	385.5	398	410.5	423	448	460.5	473	498	510.5	523	535.5	560.5	573	585.5	598	623	635.5	648	673
3	348	360.5	385.5	398	410.5	423	448	460.5	473	498	510.5	523	535.5	560.5	573	585.5	598	623	635.5	648	673	685.5	698	710.5
4	398	410.5	423	448	460.5	473	485.5	510.5	523	535.5	560.5	573	585.5	598	623	635.5	648	673	685.5	698	710.5	735.5	748	760.5
5	448	460.5	473	485.5	510.5	523	535.5	548	573	585.5	598	623	635.5	648	660.5	685.5	698	710.5	735.5	748	760.5	773	798	810.5
6	485.5	510.5	523	535.5	548	573	585.5	598	623	635.5	648	660.5	685.5	698	710.5	723	748	760.5	773	798	810.5	823	835.5	860.5
7	535.5	548	573	585.5	598	610.5	635.5	648	660.5	685.5	698	710.5	723	748	760.5	773	798	810.5	823	835.5	860.5	873	885.5	898
8	585.5	598	610.5	635.5	648	660.5	673	698	710.5	723	748	760.5	773	785.5	810.5	823	835.5	860.5	873	885.5	898	923	935.5	948
9	635.5	648	660.5	673	698	710.5	723	748	760.5	773	785.5	810.5	823	835.5	848	873	885.5	898	923	935.5	948	960.5	985.5	985.5

Dimensions

Power supply with 7/8 inch connector

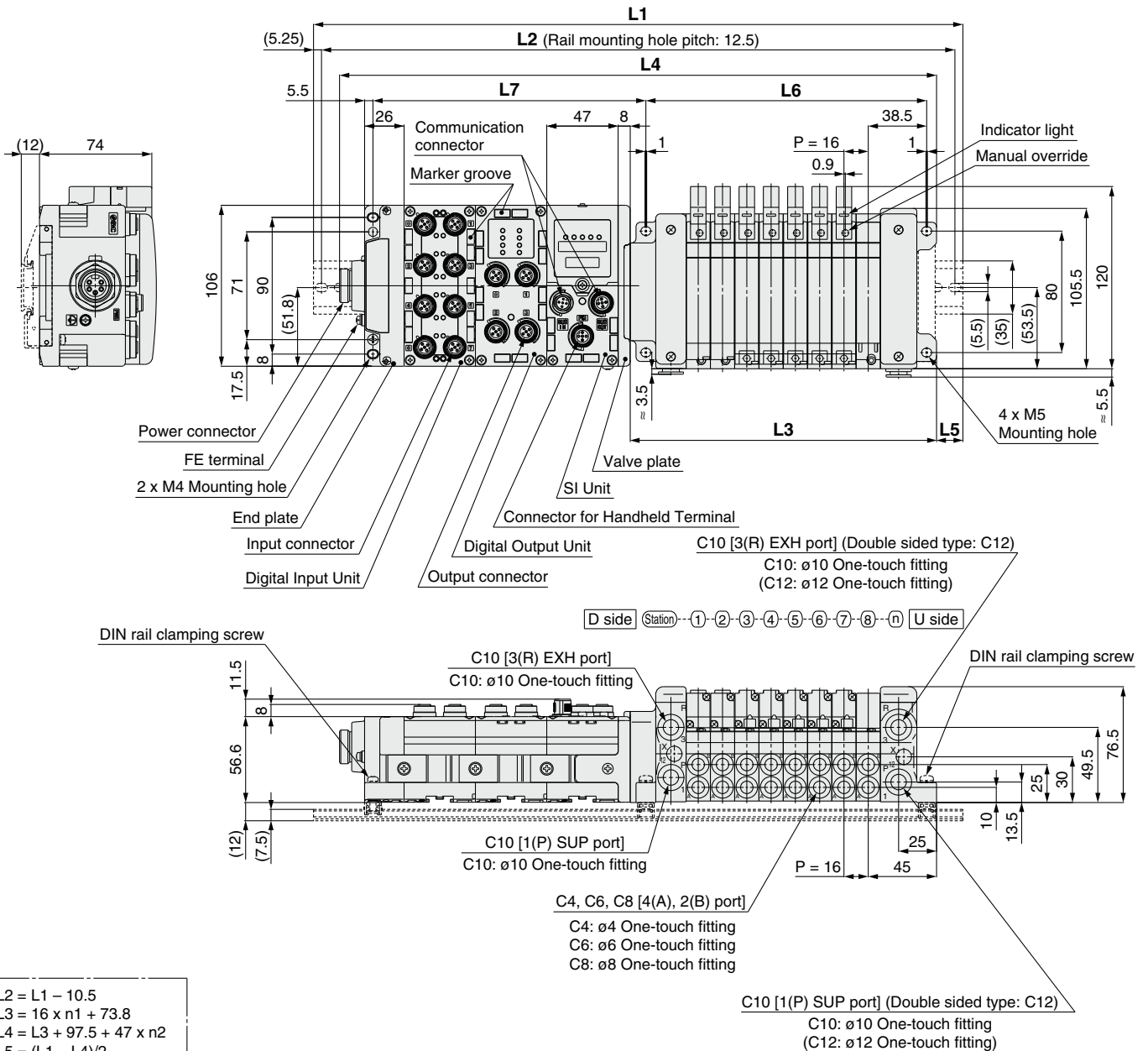

$L2 = L1 - 10.5$
 $L3 = 16 \times n1 + 73.8$
 $L4 = L3 + 97.5 + 47 \times n2$
 $L5 = (L1 - L4) / 2$
 $L6 = 16 \times n1 + 57$
 $L7 = 47 \times n2 + 85.8$

n1: Valve stations
n2: I/O Unit stations

L1: DIN Rail Overall Length

I/O Unit stations (n2) \ Valve stations (n1)	Valve stations (n1)																							
	1	2	3	4	5	6	7	8	9	10	11	12	13	14	15	16	17	18	19	20	21	22	23	24
0	223	235.5	260.5	273	285.5	298	323	335.5	348	373	385.5	398	410.5	435.5	448	460.5	485.5	498	510.5	523	548	560.5	573	585.5
1	273	285.5	298	323	335.5	348	360.5	385.5	398	410.5	435.5	448	460.5	473	498	510.5	523	548	560.5	573	585.5	610.5	623	635.5
2	323	335.5	348	360.5	385.5	398	410.5	435.5	448	460.5	473	498	510.5	523	535.5	560.5	573	585.5	610.5	623	635.5	648	673	685.5
3	360.5	385.5	398	410.5	423	448	460.5	473	498	510.5	523	535.5	560.5	573	585.5	610.5	623	635.5	648	673	685.5	698	710.5	735.5
4	410.5	423	448	460.5	473	485.5	510.5	523	535.5	560.5	573	585.5	598	623	635.5	648	673	685.5	698	710.5	735.5	748	760.5	785.5
5	460.5	473	485.5	510.5	523	535.5	560.5	573	585.5	598	623	635.5	648	660.5	685.5	698	710.5	735.5	748	760.5	773	798	810.5	823
6	510.5	523	535.5	548	573	585.5	598	623	635.5	648	660.5	685.5	698	710.5	735.5	748	760.5	773	798	810.5	823	835.5	860.5	873
7	548	573	585.5	598	610.5	635.5	648	660.5	685.5	698	710.5	723	748	760.5	773	798	810.5	823	835.5	860.5	873	885.5	910.5	923
8	598	610.5	635.5	648	660.5	685.5	698	710.5	723	748	760.5	773	785.5	810.5	823	835.5	860.5	873	885.5	898	923	935.5	948	973
9	648	660.5	673	698	710.5	723	748	760.5	773	785.5	810.5	823	835.5	860.5	873	885.5	898	923	935.5	948	960.5	985.5	998.5	—

EX600

5 Port Solenoid Valve

Series VQC4000

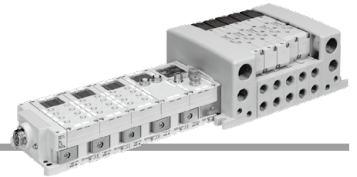

How to Order Manifold

VV5QC 4 1 - 16 02 SD6Q 2 N 1 -

Series VQC4000

Base mounted plug-in

Stations

Symbol	Stations
01	1 station
⋮	⋮
16 ^{Note)}	16 stations

Note) The maximum number of stations depends on the wiring specifications.

Cylinder port size

C8	With ø8 One-touch fitting
C10	With ø10 One-touch fitting
C12	With ø12 One-touch fitting
02	Rc1/4 ^{Note)}
03	Rc3/8 ^{Note)}
B	Bottom ported Rc1/4 ^{Note)}
CM	Mixed sizes

Note) In addition to Rc, these sizes are also compatible to G, NPT/NPTF. The part number indication is as follows.

Thread type

Nil	Rc
F	G
T	NPT/NPTF

SI Unit specifications

Symbol	Protocol	Stations	Max. number of stations for special wiring specification	Max. number of solenoids
SD60	Without SI unit	1 to 12 stations	16 stations	24
SD6Q	DeviceNet™			
SD6N	PROFIBUS DP			
SD6V	CC-Link			
SD6ZE	EtherNet/IP™ (1 port)			
SD6EA	EtherNet/IP™ (2 ports)			
SD6D	EtherCAT®			
SD6F	PROFINET			

Note) The maximum number of stations depends on the number of solenoids. Add the option symbol "K" when the combination of single wiring and double wiring is specified.

- When "Without SI Unit" is specified, I/O Unit cannot be mounted.
- When "Without SI Unit" is specified, a valve plate which connects the manifold and SI Unit, is not mounted. Refer to page 65 for mounting method.

Option

Nil	None
K ^{Note)}	Special wiring specification (Except double wiring)

Note) When single wiring and double wiring are mixed, specify wiring type of each station on the manifold specification sheet.

I/O Unit stations

Nil	None
1	1 station
⋮	⋮
9	9 stations

Note 1) Without SI Unit, the symbol is nil.

Note 2) SI Unit is not included in I/O Unit stations.

Note 3) When I/O Unit is selected, it is shipped separately and assembled by users.

Refer to the attached operation manual for mounting method.

Note 4) Refer to page 64 for details on enclosure.

SI Unit output polarity

Nil	Positive common
N	Negative common

Note) Without SI Unit, the symbol is nil.

End plate type

Nil	No end plate
2	Power supply with M12 connector (Max. supplied current 2 A)
3	Power supply with 7/8 inch connector (Max. supplied current 8 A)

Note) Without SI Unit, the symbol is nil.

How to Order Valves

VQC4100 - 5

Series VQC4000

Type of actuation

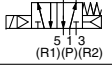
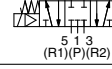
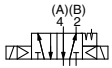
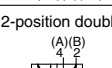
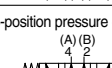
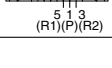
1	2-position single (A)(B) 4 2  5 1 3 (R1)(P)(R2)	3	3-position closed center (A)(B) 4 2  5 1 3 (R1)(P)(R2)
	2-position double (A)(B) 4 2  5 1 3 (R1)(P)(R2)		4
2	2-position double (A)(B) 4 2  5 1 3 (R1)(P)(R2)	5	3-position pressure center (A)(B) 4 2  5 1 3 (R1)(P)(R2)
	2-position double (A)(B) 4 2  5 1 3 (R1)(P)(R2)		6

Note) For double check type, refer to the **WEB catalog** or the VQ4000/5000 series catalog (CAT. ES11-104).

Seal type

0	Metal seal
1	Rubber seal

Manual override

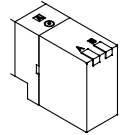
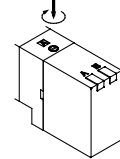
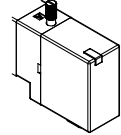
Nil: Non-locking push type (Tool required) 	B: Locking type (Tool required) 	C: Locking type (Manual) 
------------------------------------------------------------------------------------------------------------------------------------------	-------------------------------------------------------------------------------------------------------------------------------	------------------------------------------------------------------------------------------------------------------------

Light/surge voltage suppressor

Nil	With
E	Without light, with surge voltage suppressor

Coil voltage

5	24 VDC
----------	--------

Function

Nil	Standard (0.95 W)
Y <small>Note 1) 2)</small>	Low wattage type (0.4 W)
T <small>Note 1) 2)</small>	With power saving circuit (0.3 W)
R <small>Note 3)</small>	External pilot

Note 1) When the power is energized continuously for a long period of time at an operating pressure of 0.7 MPa or less (duty ratio: 50 or more), be sure to select low wattage type. When the power is energized continuously for a long period of time at an operating pressure exceeding 0.7 MPa (duty ratio: 50 or more), be sure to select power saving type. Please contact SMC if anything is unclear.

Note 2) There is no combination of Y and T. Also, Y and T are only for DC.

Note 3) For details about external pilot type, refer to the **WEB catalog** or the VQ4000/5000 series catalog (CAT.ES11-104). In addition, external pilot type cannot be combined with a double check spacer.

Note 4) When multiple symbols are specified, indicate them alphabetically.

Series EX600

Series SY

Series SV

Series S0700

Series VQC

Series VQC4000

Dimensions

Power supply with M12 connector

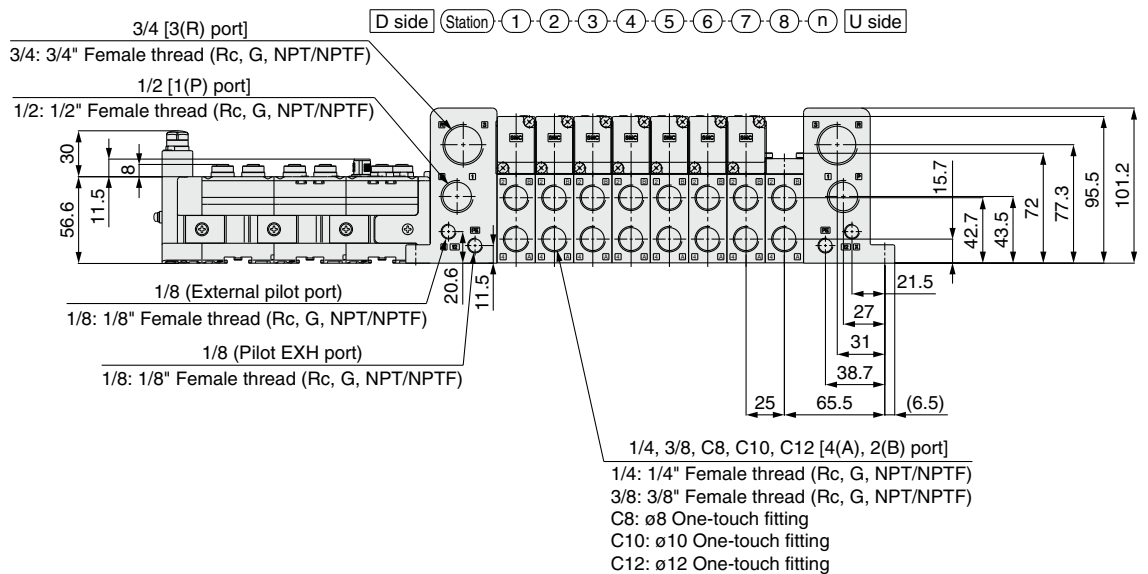
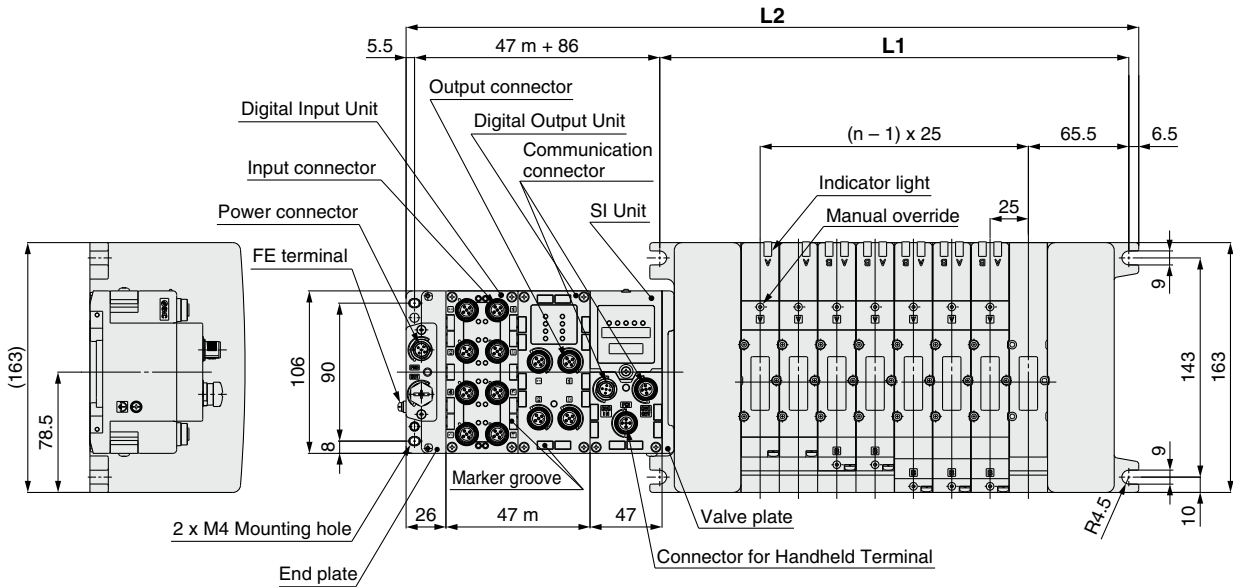

Formulas

$$L1 = 25n + 106$$

$$L2 = 25n + 184$$

* L2 is the dimension without I/O Unit. Add 47 mm for each additional I/O Units.

* "m" is number of I/O Units.

Dimensions

n: Stations (Maximum 16 stations)

L \ n	1	2	3	4	5	6	7	8	9	10	11	12	13	14	15	16
L1	131	156	181	206	231	256	281	306	331	356	381	406	431	456	481	506
L2	209	234	259	284	309	334	359	384	409	434	459	484	509	534	559	584

Dimensions

Power supply with 7/8 inch connector

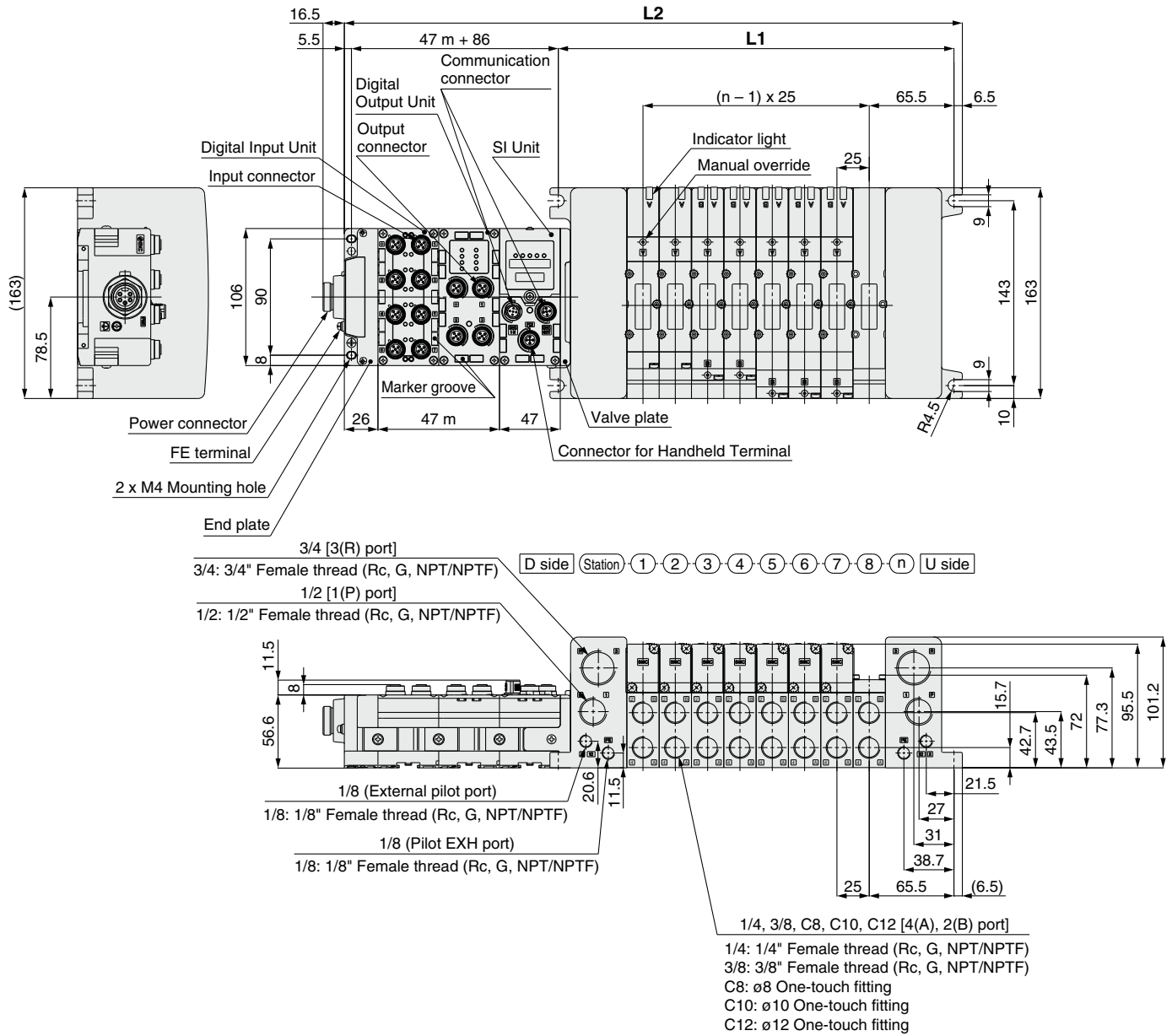

Formulas

$$L1 = 25n + 106$$

$$L2 = 25n + 184$$

* L2 is the dimension without I/O Unit. Add 47 mm for each additional I/O Units.

* "m" is number of I/O Units.

Dimensions

n: Stations (Maximum 16 stations)

n	1	2	3	4	5	6	7	8	9	10	11	12	13	14	15	16
L1	131	156	181	206	231	256	281	306	331	356	381	406	431	456	481	506
L2	209	234	259	284	309	334	359	384	409	434	459	484	509	534	559	584



Series EX600

Specific Product Precautions 1

Be sure to read this before handling. Refer to the back cover for Safety Instructions. For 3/4/5 Port Solenoid Valve Precautions, refer to "Handling Precautions for SMC Products" and the Operation Manual on SMC website, <http://www.smcworld.com>

Design/ Selection

Warning

- 1. Do not use beyond the specification range.**
Using beyond the specification range can cause a fire, malfunction, or damage to the system.
Check the specifications before operation.
- 2. When using for an interlock circuit:**
 - **Provide a multiple interlock system which is operated by another system (such as mechanical protection function).**
 - **Perform an inspection to confirm that it is working properly.**
Otherwise, this may cause possible injuries due to malfunction.

Caution

- 1. When applicable to UL, use a Class 2 power supply unit conforming to UL1310 for direct current power supply.**
- 2. Use within the specified voltage range.**
Using beyond the specified voltage range is likely to cause the product to be damaged or to malfunction.
- 3. Do not install in places where it can be used as a foothold.**
Applying any excessive load such as stepping on the product by mistake or placing a foot on it, will cause it to break.
- 4. Keep the surrounding space free for maintenance.**
When designing a system, take into consideration the amount of free space needed for performing maintenance.
- 5. Do not remove the name plate.**
Improper maintenance or incorrect use of Operation Manual can cause equipment failure or malfunction. Also, there is a risk of losing conformity with safety standards.
- 6. Beware of inrush current when the power supply is turned on.**
Some connected loads can apply an initial charge current which will trigger the over current protection function, causing the Unit to malfunction.

Mounting

Caution

- 1. When handling and assembling Units:**
 - **Do not touch the sharp metal parts of the connector or plug.**
 - **Do not apply excessive force to the Unit when disassembling.**
The connecting portions of the Unit are firmly joined with seals.
 - **When joining Units, take care not to get fingers caught between Units.**
Injury can result.
- 2. Do not drop, bump, or apply excessive impact.**
Otherwise, this can cause damage, equipment failure or malfunction.

Mounting

Caution

- 3. Observe the tightening torque range.**
Tightening outside of the allowable torque range will likely damage the screw.
IP67 cannot be guaranteed if the screws are not tightened to the specified torque.
- 4. When lifting a large size Manifold Solenoid Valve Unit, take care to avoid causing stress to the valve connection joint.**
The connection joint with the Unit may be damaged.
Because the product may be heavy, carrying and installation should be performed by more than one operator to avoid strain or injury.
- 5. When placing a manifold, mount it on a flat surface.**
Torsion in the whole manifold can lead to trouble such as air leakage or contact failure.

Wiring

Caution

- 1. Provide the grounding to maintain the safety of the reduced wiring system and to improve the noise immunity.**
Provide a specific grounding as close to the Unit as possible to minimize the distance to grounding.
- 2. Avoid repeatedly bending or stretching the cable and applying a heavy object or force to it.**
Wiring applying repeated bending and tensile stress to the cable can break the circuit.
- 3. Avoid miswiring.**
If miswired, there is a danger of malfunction or damage to the reduced wiring system.
- 4. Do not wire while energizing the product.**
There is a danger of malfunction or damage to the reduced wiring system or input/output device.
- 5. Avoid wiring the power line and high pressure line in parallel.**
Noise or surge produced by signal line resulting from the power line or high pressure line could cause a malfunction.
Wiring of the reduced wiring system or input/output device and the power line or high pressure line should be separated from each other.
- 6. Check for the wiring insulation.**
Defective insulation (contact with other circuits, improper insulation between terminals, etc.) may cause damage to the reduced wiring system or input/output device due to excessive voltage or current.



Series EX600

Specific Product Precautions 2

Be sure to read this before handling. Refer to the back cover for Safety Instructions. For 3/4/5 Port Solenoid Valve Precautions, refer to "Handling Precautions for SMC Products" and the Operation Manual on SMC website, <http://www.smcworld.com>

Wiring

Caution

- 7. When the reduced wiring system is installed in machinery/equipment, provide adequate protection against noise by using noise filters etc.**
Noise in signal lines may cause a malfunction.
- 8. When connecting wires of input/output device or Handheld Terminal, prevent water, solvent or oil from entering inside from the connector section.**
Otherwise, this can cause damage, equipment failure or malfunction.
- 9. Avoid wiring patterns in which excessive stress is applied to the connector.**
This may cause equipment failure or malfunction due to contact failure.

Operating Environment

Warning

- 1. Do not use in an atmosphere containing an inflammable gas or explosive gas.**
Use in such an atmosphere is likely to cause a fire or explosion. This system is not explosion-proof.

Caution

- 1. Select the proper type of enclosure according to the environment of operation.**
IP65/67 is achieved when the following conditions are met.
 - 1) Provide appropriate wiring between Units using electrical wiring cables, communication connectors and cables with M12 connectors.
 - 2) Suitable mounting of each Unit and manifold valve.
 - 3) Be sure to mount a seal cap on any unused connectors.If using in an environment that is exposed to water splashes, please take measures such as using a cover.
When the enclosure is IP40, do not use in an operating environment or atmosphere where it may come in contact with corrosive gas, chemical agents, seawater, water, or water vapor. When connected to the EX600-D□□E or EX600-D□□F, manifold enclosure is IP40.
Also, the Handheld Terminal conforms to IP20, so prevent foreign matter from entering inside, and water, solvent or oil from coming in direct contact with it.
- 2. Provide adequate protection when operating in locations such as the following.**
Failure to do so may cause a malfunction or equipment failure. The effect of countermeasures should be checked in individual equipment and machine.
 - 1) Where noise is generated by static electricity etc.
 - 2) Where there is a strong electric field
 - 3) Where there is a danger of exposure to radiation
 - 4) When in close proximity to power supply lines

Operating Environment

Caution

- 3. Do not use in an environment where oil and chemicals are used.**
Operating in environments with coolants, cleaning solvents, various oils or chemicals may cause adverse effects (damage, malfunction) to the Unit even in a short period of time.
- 4. Do not use in an environment where the product could be exposed to corrosive gas or liquid.**
This may damage the Unit and cause it to malfunction.
- 5. Do not use in locations with sources of surge generation.**
Installation of the Unit in an area around the equipment (electromagnetic lifters, high frequency induction furnaces, welding machine, motors, etc.), which generates the large surge voltage could cause to deteriorate an internal circuitry element of the Unit or result in damage. Implement countermeasures against the surge from the generating source, and avoid touching the lines with each other.
- 6. Use the product type that has an integrated surge absorption element when directly driving a load which generates surge voltage by relay, solenoid valves or lamp.**
When a surge generating load is directly driven, the Unit may be damaged.
- 7. The product is CE marked, but not immune to lightning strikes. Take measures against lightning strikes in your system.**
- 8. Keep dust, wire scraps and other foreign matter from entering inside the product.**
This may cause equipment failure or malfunction.
- 9. Mount the Unit in such locations, where no vibration or shock is affected.**
This may cause equipment failure or malfunction.
- 10. Do not use in places where there are cyclic temperature changes.**
In case that the cyclic temperature is beyond normal temperature changes, the internal Unit is likely to be adversely affected.
- 11. Do not use in direct sunlight.**
This may cause equipment failure or malfunction.
- 12. Observe the ambient temperature range.**
This may cause a malfunction.
- 13. Do not use in places where there is radiated heat around it.**
Such places are likely to cause a malfunction.



Series EX600

Specific Product Precautions 3

Be sure to read this before handling. Refer to the back cover for Safety Instructions. For 3/4/5 Port Solenoid Valve Precautions, refer to "Handling Precautions for SMC Products" and the Operation Manual on SMC website, <http://www.smcworld.com>

Adjustment/ Operation

⚠ Warning

1. **Do not perform operation or setting with wet hands.**
There is a risk of electrical shock.

<Handheld Terminal>

2. **Do not apply pressure to the LCD.**
There is a possibility of the crack of LCD and injuring.
3. **The forced input/output function is used to change the signal status forcibly. When operating this function, be sure to check the safety of the surroundings and installation.**
This may cause, injuries or equipment damage.
4. **Incorrect setting of parameters can cause a malfunction. Be sure to check the settings before use.**
This may cause injuries or equipment damage.

⚠ Caution

1. **Use a watchmakers' screwdriver with thin blade for the setting of each switch of the SI Unit. When setting the switch, do not touch other unrelated parts.**
This may cause parts damage or malfunction due to a short circuit.
2. **Provide adequate setting for the operating conditions.**
Failure to do so could result in malfunction. Refer to the Operation Manual for setting of the switches.
3. **For details on programming and address setting, refer to the manual from the PLC manufacturer.**
The content of programming related to protocol is designed by the manufacturer of the PLC used.

<Handheld Terminal>

4. **Do not press the setting buttons with a sharp pointed object.**
This may cause damage or equipment failure.
5. **Do not apply excessive load and impact to the setting buttons.**
This may cause damage, equipment failure or malfunction.

When the order does not include the SI Unit, a valve plate which connects the manifold and SI Unit, is not mounted. Use attached valve holding screws and mount the valve plate.
(Tightening torque: 0.6 to 0.7 N·m)

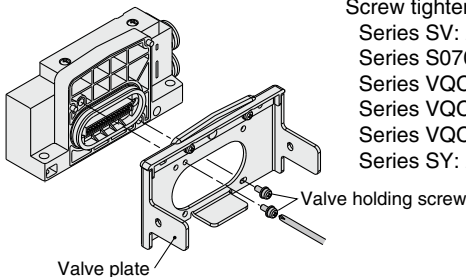

Screw tightened parts
 Series SV: 2 places
 Series S0700: 2 places
 Series VQC1000: 2 places
 Series VQC2000: 3 places
 Series VQC4000: 4 places
 Series SY: 2 places

Maintenance

⚠ Warning

1. **Do not disassemble, modify (including circuit board replacement) or repair this product.**
Such actions are likely to cause injuries or equipment failure.
2. **When an inspection is performed,**
 - Turn off the power supply.
 - Stop the air supply, exhaust the residual pressure in piping and verify that the air is released before performing maintenance work.
 Unexpected malfunction of system components and injury can result.

⚠ Caution

1. **When handling and replacing Units:**
 - Do not touch the sharp metal parts of the connector or plug.
 - Do not apply excessive force to the Unit when disassembling.
The connecting portions of the Unit are firmly joined with seals.
 - When joining Units, take care not to get fingers caught between Units.
Injury can result.
2. **Perform periodic inspection.**
Unexpected malfunction in the system composition devices is likely to occur due to malfunction of machinery or equipment.
3. **After maintenance, make sure to perform an appropriate functionality inspection.**
In cases of abnormality such as faulty operation, stop operation. Unexpected malfunction in the system composition devices is likely to occur.
4. **Do not use benzine and thinner for cleaning Units.**
Damage to the surface or erasure of the display can result. Wipe off any stains with a soft cloth. If the stain is persistent, wipe off with a cloth soaked in a dilute solution of neutral detergent and wrung out tightly, and then finish with a dry cloth.

Other

⚠ Caution

1. **Refer to the catalog of each series for Common Precautions and Specific Product Precautions on manifold solenoid valves.**

■ Trademark

DeviceNet™ is a trademark of ODVA.
 EtherNet/IP™ is a trademark of ODVA.
 EtherCAT® is registered trademark and patented technology, licensed by Beckhoff Automation GmbH, Germany.
 QuickConnect™ is a trademark of ODVA.

Safety Instructions

These safety instructions are intended to prevent hazardous situations and/or equipment damage. These instructions indicate the level of potential hazard with the labels of “**Caution**,” “**Warning**” or “**Danger**.” They are all important notes for safety and must be followed in addition to International Standards (ISO/IEC)*1), and other safety regulations.

 **Caution:** **Caution** indicates a hazard with a low level of risk which, if not avoided, could result in minor or moderate injury.

 **Warning:** **Warning** indicates a hazard with a medium level of risk which, if not avoided, could result in death or serious injury.

 **Danger :** **Danger** indicates a hazard with a high level of risk which, if not avoided, will result in death or serious injury.

*1) ISO 4414: Pneumatic fluid power – General rules relating to systems.
 ISO 4413: Hydraulic fluid power – General rules relating to systems.
 IEC 60204-1: Safety of machinery – Electrical equipment of machines.
 (Part 1: General requirements)
 ISO 10218-1: Manipulating industrial robots – Safety.
 etc.

Warning

1. The compatibility of the product is the responsibility of the person who designs the equipment or decides its specifications.

Since the product specified here is used under various operating conditions, its compatibility with specific equipment must be decided by the person who designs the equipment or decides its specifications based on necessary analysis and test results. The expected performance and safety assurance of the equipment will be the responsibility of the person who has determined its compatibility with the product. This person should also continuously review all specifications of the product referring to its latest catalog information, with a view to giving due consideration to any possibility of equipment failure when configuring the equipment.

2. Only personnel with appropriate training should operate machinery and equipment.

The product specified here may become unsafe if handled incorrectly. The assembly, operation and maintenance of machines or equipment including our products must be performed by an operator who is appropriately trained and experienced.

3. Do not service or attempt to remove product and machinery/equipment until safety is confirmed.

1. The inspection and maintenance of machinery/equipment should only be performed after measures to prevent falling or runaway of the driven objects have been confirmed.
2. When the product is to be removed, confirm that the safety measures as mentioned above are implemented and the power from any appropriate source is cut, and read and understand the specific product precautions of all relevant products carefully.
3. Before machinery/equipment is restarted, take measures to prevent unexpected operation and malfunction.

4. Contact SMC beforehand and take special consideration of safety measures if the product is to be used in any of the following conditions.

1. Conditions and environments outside of the given specifications, or use outdoors or in a place exposed to direct sunlight.
2. Installation on equipment in conjunction with atomic energy, railways, air navigation, space, shipping, vehicles, military, medical treatment, combustion and recreation, or equipment in contact with food and beverages, emergency stop circuits, clutch and brake circuits in press applications, safety equipment or other applications unsuitable for the standard specifications described in the product catalog.
3. An application which could have negative effects on people, property, or animals requiring special safety analysis.
4. Use in an interlock circuit, which requires the provision of double interlock for possible failure by using a mechanical protective function, and periodical checks to confirm proper operation.

Caution

1. The product is provided for use in manufacturing industries.

The product herein described is basically provided for peaceful use in manufacturing industries.
 If considering using the product in other industries, consult SMC beforehand and exchange specifications or a contract if necessary.
 If anything is unclear, contact your nearest sales branch.

Limited warranty and Disclaimer/ Compliance Requirements

The product used is subject to the following “Limited warranty and Disclaimer” and “Compliance Requirements”.

Read and accept them before using the product.

Limited warranty and Disclaimer

1. The warranty period of the product is 1 year in service or 1.5 years after the product is delivered, whichever is first.*2)
 Also, the product may have specified durability, running distance or replacement parts. Please consult your nearest sales branch.
2. For any failure or damage reported within the warranty period which is clearly our responsibility, a replacement product or necessary parts will be provided.
 This limited warranty applies only to our product independently, and not to any other damage incurred due to the failure of the product.
3. Prior to using SMC products, please read and understand the warranty terms and disclaimers noted in the specified catalog for the particular products.

*2) Vacuum pads are excluded from this 1 year warranty.

A vacuum pad is a consumable part, so it is warranted for a year after it is delivered.
 Also, even within the warranty period, the wear of a product due to the use of the vacuum pad or failure due to the deterioration of rubber material are not covered by the limited warranty.

Compliance Requirements

1. The use of SMC products with production equipment for the manufacture of weapons of mass destruction (WMD) or any other weapon is strictly prohibited.
2. The exports of SMC products or technology from one country to another are governed by the relevant security laws and regulations of the countries involved in the transaction. Prior to the shipment of a SMC product to another country, assure that all local rules governing that export are known and followed.

Caution

SMC products are not intended for use as instruments for legal metrology.

Measurement instruments that SMC manufactures or sells have not been qualified by type approval tests relevant to the metrology (measurement) laws of each country. Therefore, SMC products cannot be used for business or certification ordained by the metrology (measurement) laws of each country.

Revision history

Edition B * EtherNet/IP™ communication protocol added.
 * Analog Output Unit and Input/Output Unit added.
 * D-sub connector and Spring type terminal block added.
 * Applicable solenoid valve SY3000/5000 series added.
 * Number of pages decreased from 64 to 60.

OW

Edition C * EtherCAT® communication protocol added.

PX

Edition D * PROFINET communication protocol added.

RS

Edition E * Dual port EtherNet/IP™ product added.
 * Applicable solenoid valve SY7000 series added.

TS

 **Safety Instructions** Be sure to read “Handling Precautions for SMC Products” (M-E03-3) before using.

Fieldbus System (Gateway Decentralized Type) Decentralized valve installation

New



Valves can be installed
near the actuators!

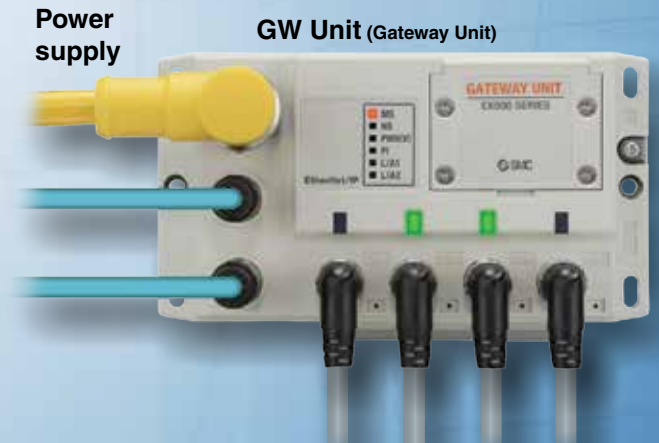

- Reduced piping space and piping materials
- Reduced wiring space
- No need to set the address for the valve manifold and Input Unit.

Description	Compatible protocol	Number of inputs/outputs	Number of valve manifold and Input Unit connections	Branch cable length	New function
New Gateway Decentralized System 2 Page 8	EtherNet/IP	128 inputs/ 128 outputs	Max. 16 Units	Max. 20 m	Web server function <ul style="list-style-type: none"> Valve operation test Connection diagnostic Short-circuit diagnostic Page 2
Gateway Decentralized System Page 46	DeviceNet	64 inputs/ 64 outputs	Max. 8 Units	Max. 10 m	—



Series EX500

Gateway Decentralized System 2 (128 Points)

● Number of branch ports: 4

Number of inputs/outputs **128** inputs/**128** outputs

● Number of inputs/outputs per branch: Max. 32 inputs/32 outputs

Number of valve manifold connections Max. **8** Units*

Number of Input Unit connections Max. **8** Units

● Number of valve manifold connections per branch: Max. 2 Units*

● Number of Input Unit connections per branch: Max. 2 Units

Total cable length per branch Max. **20** m

* When the number of outputs is set to "16 outputs" using a built-in setting switch of the SI Unit.

Maximum number of inputs: **128** points Maximum number of outputs: **128** points

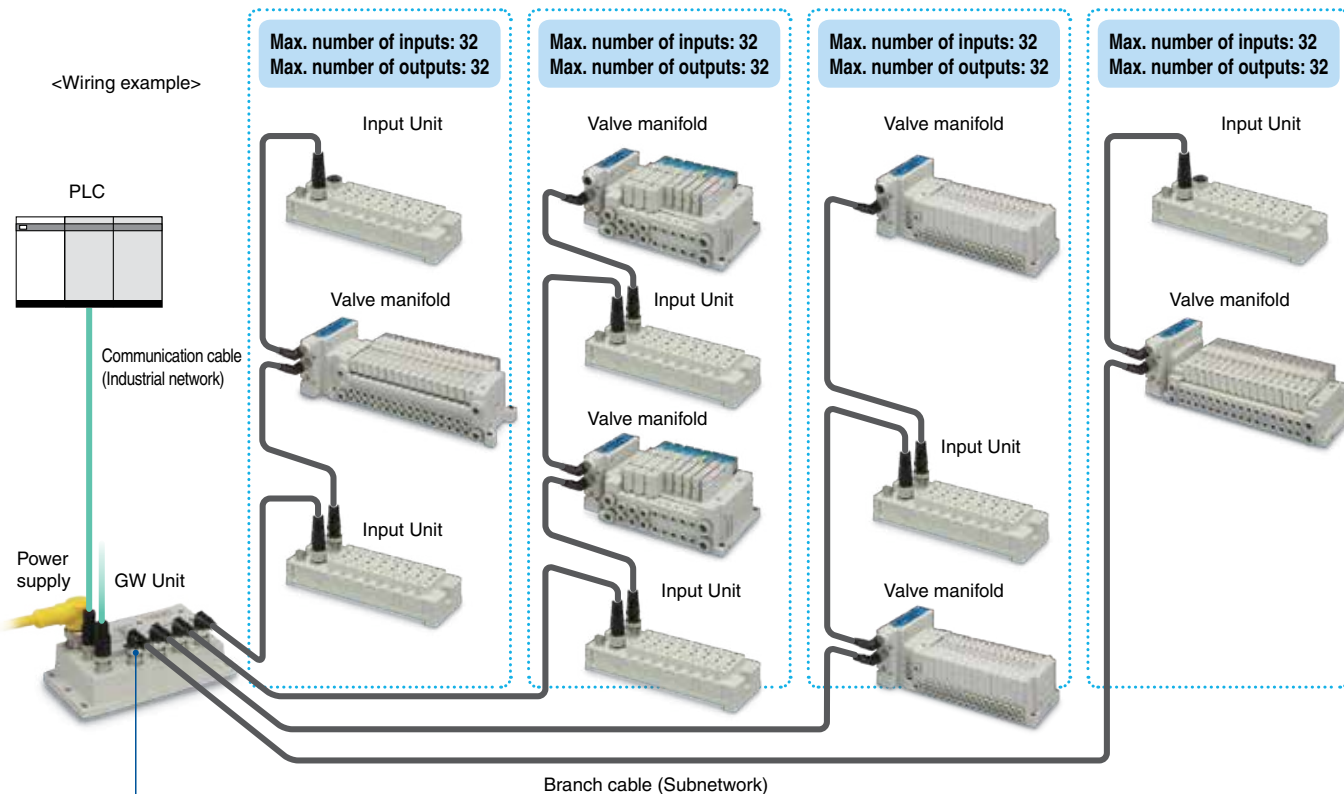

Branch port

Two valve manifolds can be connected to one branch port.

SI Unit has a built-in setting switch which switches the number of outputs (32 points / 16 points) of the valve manifold connected to the SI Unit. By setting the number of outputs to 16 points, two valve manifolds can be installed to one branch port.

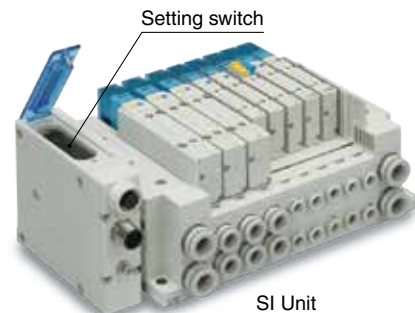

SI Unit



Web server function

Valve operation test (ON/OFF), connection diagnostic between valve manifold and Input Unit, and short-circuit diagnostic of input device can be performed on a Web browser.

A password can be used for the valve operation test (ON/OFF) for security.

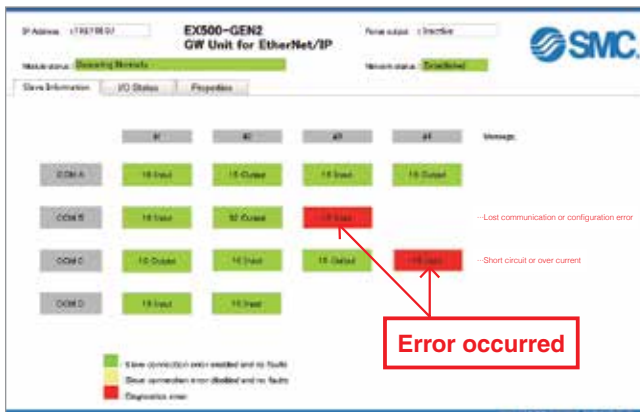

The location of the error can be identified. Details of the error can be identified on a Web browser.



* WEB display example



RJ-45 connector

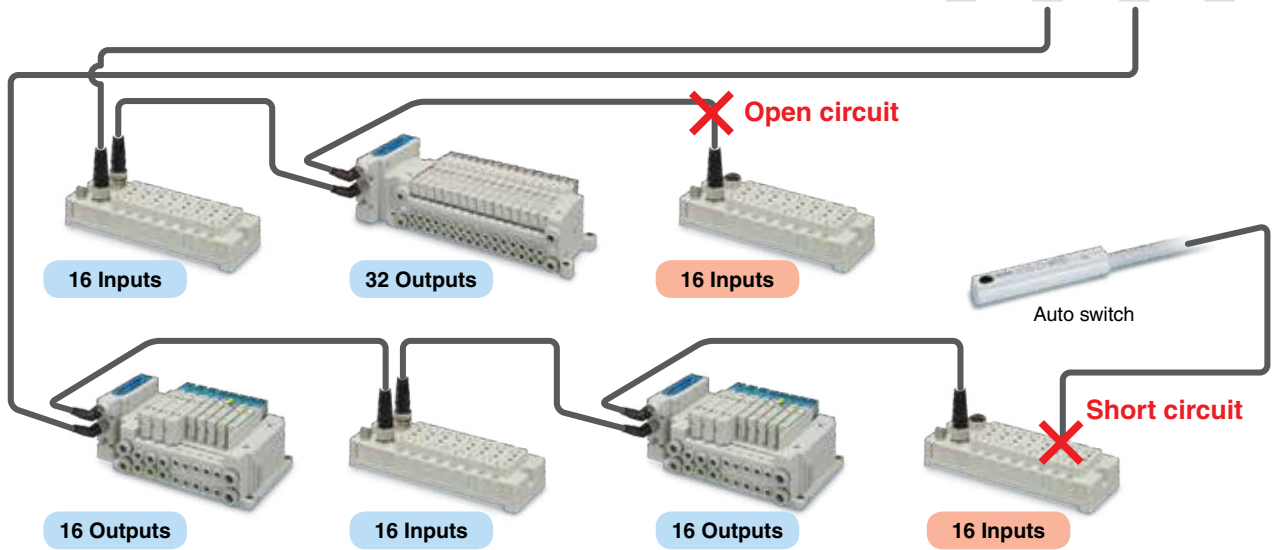
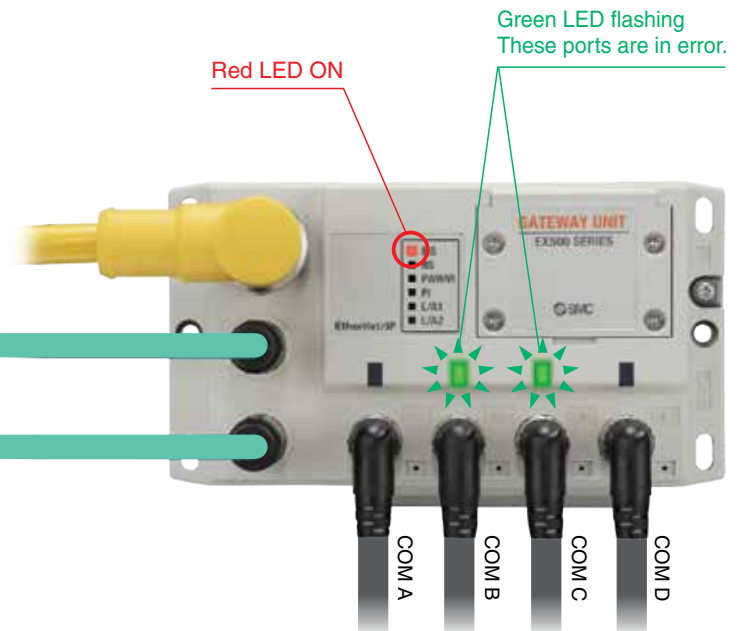

No need to set the address

I/O mapping for the SI Unit and Input Unit is set by the Gateway Unit automatically. The Unit installation order is not specified.

(The upper limit of the inputs / outputs is 32 points for one branch port.)

Gateway Decentralized System 2 (128 Points)

Accessories can be ordered together. Page 12 Page 54

Accessories including cables and connectors can be ordered together to SMC.
Time for selecting parts, ordering and managing lead time can be reduced.



Applicable to output devices other than valve manifold. Page 14

By using output block, lights and buzzers can be operated.

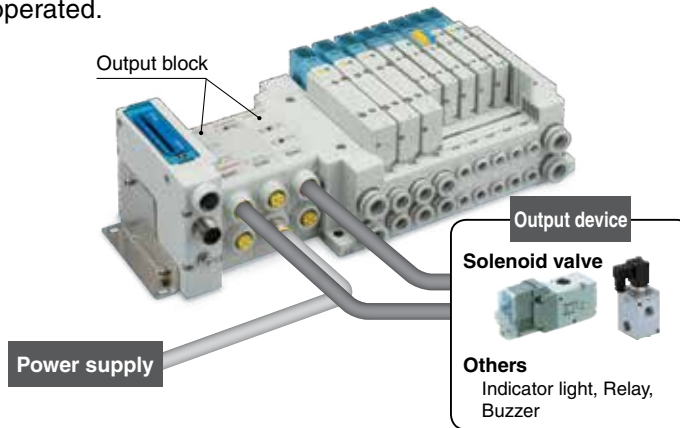

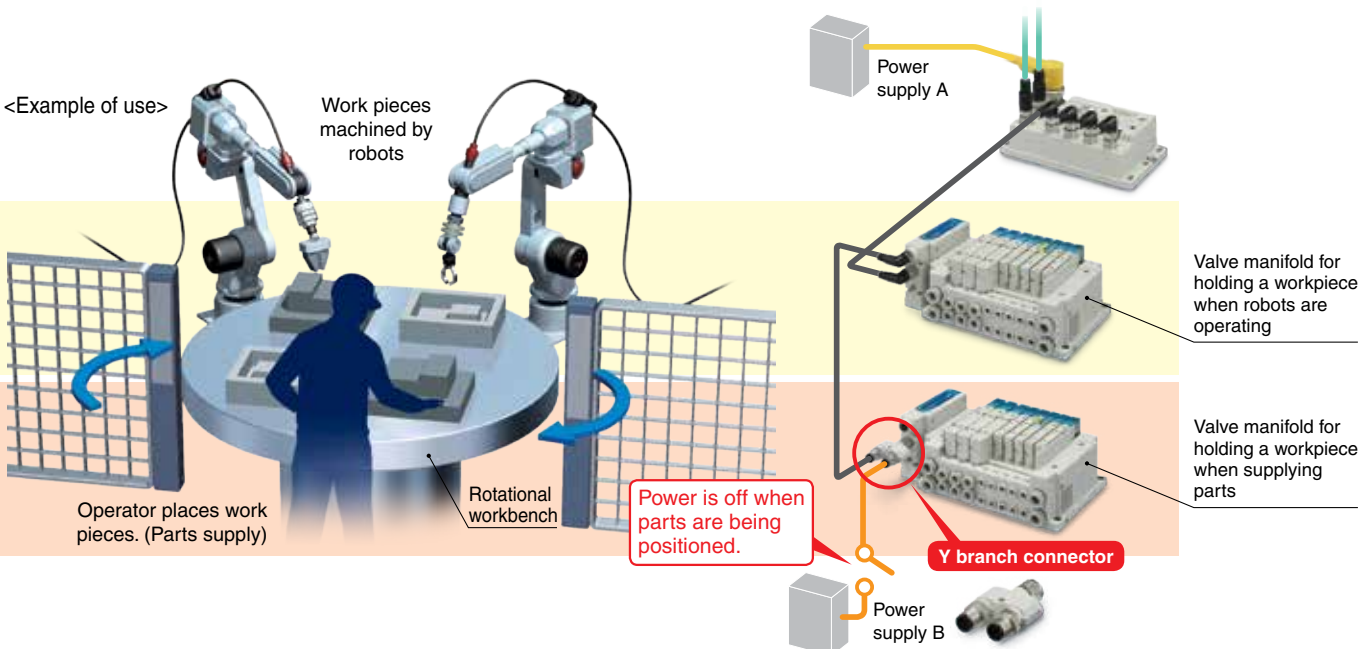

Specified valve manifold can be controlled by supplying power from a different system. Page 13

By using a Y branch connector, power from a different system can be supplied to the SI Unit (valve manifold).











System Comparison Table

	 Gateway Decentralized System	Gateway Decentralized System (Current model)
Protocol	EtherNet/IP [®]	DeviceNet [™] 
Number of inputs/outputs (Number of inputs/outputs per branch)	128 inputs/128 outputs (32 inputs/32 outputs)	64 inputs/64 outputs (16 inputs/16 outputs)
Number of valve manifold connections (Number of connections per branch)	Max. 8 Units* (Max. 2 Units)	Max. 4 Units (1 Unit)
Number of Input Unit connections (Number of connections per branch)	Max. 8 Units (Max. 2 Units)	Max. 4 Units (1 Unit)
Branch cable length	Max. 20 m	Max. 10 m
Enclosure	GW Unit: IP65 SI Unit: IP67 Input Unit: IP67	GW Unit: IP65 SI Unit: IP67 Input Unit: IP65
Function	Web server function (Valve operation test, Connection diagnostic, Short-circuit diagnostic)	—
Page	8	46

* When the number of outputs is set to "16 outputs" using a built-in setting switch of the SI Unit.

Applicable Valve Series

Series	Flow rate characteristics (4/2→5/3)		Maximum number of solenoids	Power consumption [W]	Enclosure	International standard	Page	
	C [dm ³ /(s·bar)]	b						
	SY3000	1.6	0.19	32	0.35 (Standard) 0.1 (With power saving circuit) [Inrush 0.4, Holding 0.1]		CE	17
	SY5000	3.6	0.17					
	SY7000	5.9	0.20					
	VQC1000	1.0 <small>Note)</small>	0.30 <small>Note)</small>	24	0.4 (Standard)		CE	25
	VQC2000	3.2 <small>Note)</small>	0.30 <small>Note)</small>					
	VQC4000	7.3 <small>Note)</small>	0.38 <small>Note)</small>					
	VQC5000	17.0 <small>Note)</small>	0.31 <small>Note)</small>					
	S0700	0.37	0.39	32	0.35		CE	37
	SV1000	1.1	0.35	32	0.6		CE	40
	SV2000	2.4	0.18					
	SV3000	4.3	0.21					

Note) Values for 2-position single, rubber seal type

Series SY3000/5000/7000

Piping on the top or the bottom makes the footprint smaller to realize dramatic space-saving.



Valve piping direction variations

Piping is possible from 3 directions.

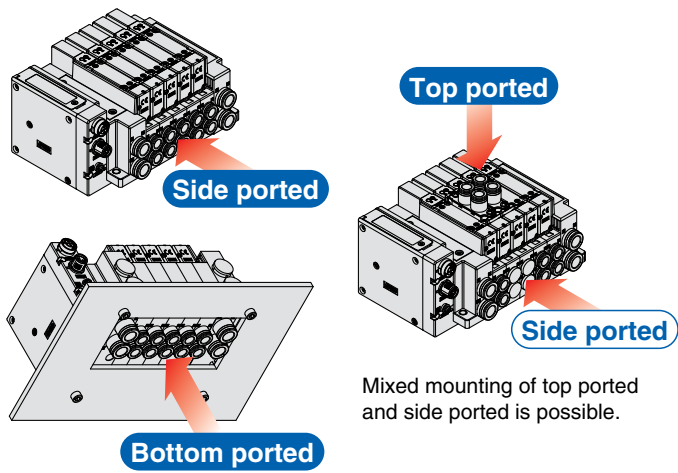

Max. 24 stations connectable

It is possible to connect only the number of valves required, from 1 to 24 stations, to suit the application. (Maximum number of solenoids: 32)

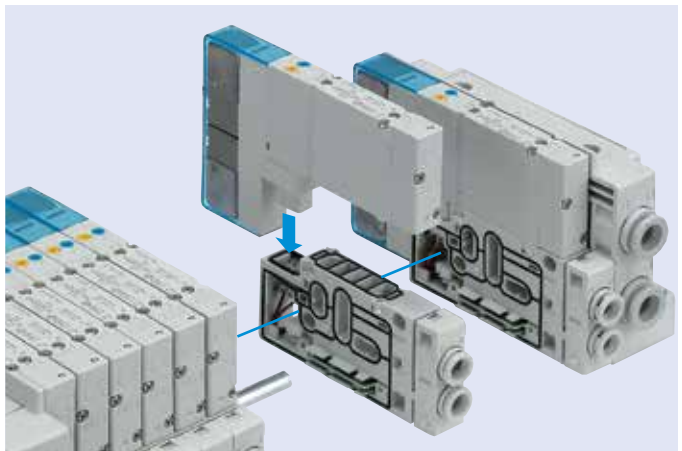

Mixed valve sizes manifold

It is also possible to install a combination of different-sized valves on the same manifold. (SY3000 and SY5000, or SY5000 and SY7000)

This facilitates reduction in the installation space and number of units/cables.

Example: For SY5000 and SY3000

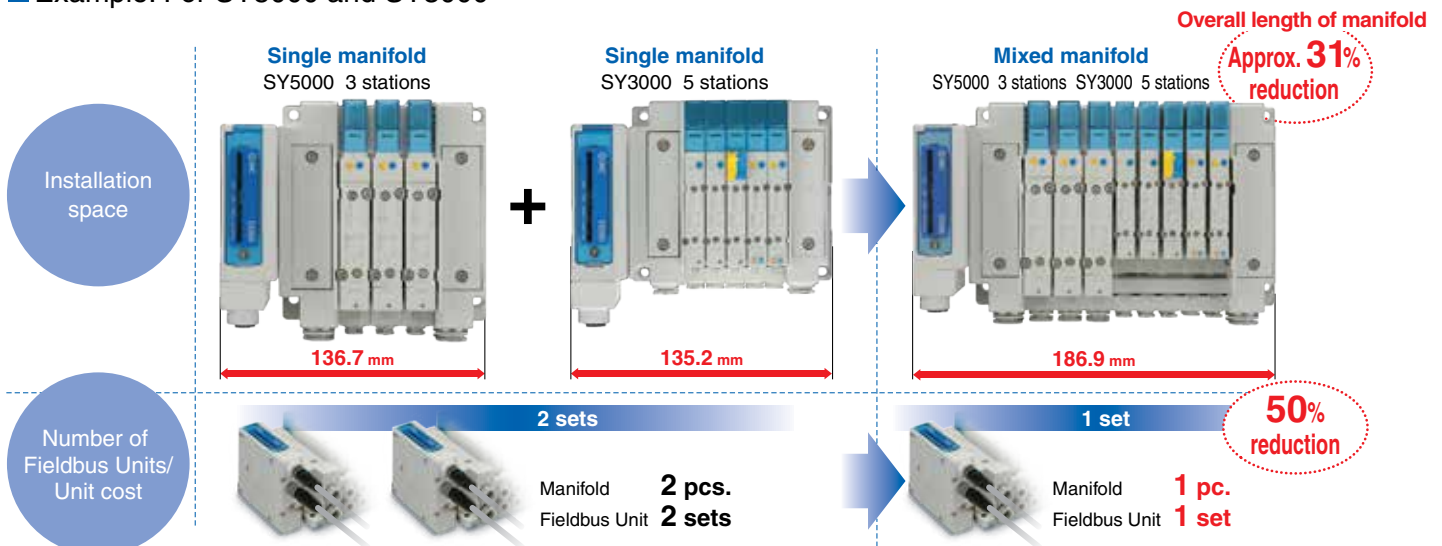

CONTENTS

Fieldbus System (Gateway Decentralized Type) Series EX500

■ Features (Gateway Decentralized System 2)	Page 1
■ System Comparison Table/Applicable Valve Series	Page 4
■ Introduction of the SY Series Valve	Page 5

Series EX500 Gateway Decentralized System 2 (128 Points) **Page 8**



■ GW Unit	
How to Order	Page 9
Specifications	Page 9
Dimensions/Parts Description	Page 9
■ SI Unit	
How to Order	Page 10
Specifications	Page 10
Dimensions/Parts Description	Page 10
■ Input Unit	
How to Order	Page 11
Specifications	Page 11
Dimensions/Parts Description	Page 11
■ Accessories	
• Branch Cable • Power Supply Cable • Communication Cable/Connector	Page 12
• Y Branch Connector • Cable for Power Supply from a Different System	Page 13
• Marker • Seal Cap • DIN Rail Bracket	Page 13
• Output Block	Page 14
• Power Block	Page 14
• Connector for Output Block Wiring • Power Supply Cable for Power Block	Page 15
• End Plate • Bracket Plate	Page 16



■ SY3000/5000/7000	
How to Order: Type 10/Type 11	Page 17
Type 12	Page 20
Dimensions: Type 10 SY3000	Page 22
SY5000	Page 23
SY7000	Page 24
For dimensions of Type 11 and Type 12, refer to the SY series catalog (CAT. NAS11-103).	

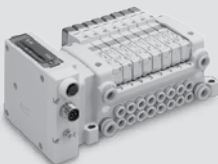

■ VQC1000	
How to Order	Page 25
Dimensions	Page 27

■ VQC2000	
How to Order	Page 28
Dimensions	Page 30

■ VQC4000	
How to Order	Page 31
Dimensions	Page 33

■ VQC5000	
How to Order	Page 34
Dimensions	Page 36



■ S0700	
How to Order	Page 37
Dimensions	Page 39



■ SV1000/2000/3000	
How to Order	Page 40
Dimensions: Tie-rod Base SV1000	Page 42
SV2000	Page 43
SV3000	Page 44

■ Precautions on Mixed Usage of Gateway Decentralized System 2 and Gateway Decentralized System	Page 45
-------------------------------------------------------------------------------------------------------	---------

CONTENTS

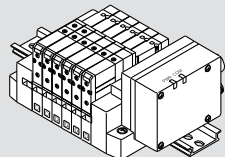
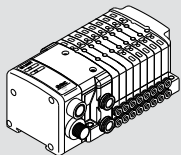
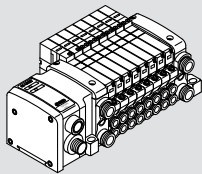
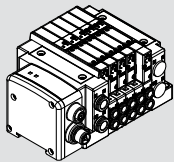
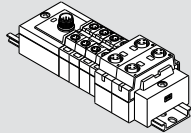
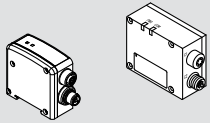
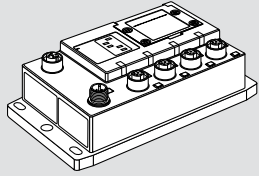

■ GW Unit			
How to Order			Page 47
Specifications			Page 47
Dimensions/Parts Description			Page 47
■ SI Unit (for SV)			
How to Order			Page 48
Specifications			Page 48
Dimensions/Parts Description			Page 48
■ SI Unit (for SY/VQC/S0700)			
How to Order			Page 49
Specifications			Page 49
Dimensions/Parts Description			Page 49
■ Input Manifold			
How to Order			Page 50
Specifications			Page 51
Dimensions/Parts Description			Page 52
How to Add Input Block Stations			Page 53
■ Accessories			
• Communication Cable			Page 54
• Power Supply Cable • Branch Cable			Page 55
• Terminal Plug • Seal Cap			Page 56
■ SY3000/5000/7000			
How to Order: Type 10/Type 11			Page 57
Type 12			Page 60
Dimensions: Type 10 SY3000			Page 62
SY5000			Page 63
SY7000			Page 64
		For dimensions of Type 11 and Type 12, refer to the SY series catalog (CAT. NAS11-103).	
■ VQC1000			
How to Order			Page 65
Dimensions			Page 67
■ VQC2000			
How to Order			Page 68
Dimensions			Page 70
■ VQC4000			
How to Order			Page 71
Dimensions			Page 73
■ VQC5000			
How to Order			Page 74
Dimensions			Page 76
■ S0700			
How to Order			Page 77
Dimensions			Page 79
■ SV1000/2000/3000/4000			
How to Order			Page 80
Dimensions: Cassette Base SV1000			Page 82
SV2000			Page 83
Tie-rod Base SV1000			Page 84
SV2000			Page 85
SV3000			Page 86
SV4000			Page 87

Series EX500

Gateway Decentralized System 2 (128 Points)

- ★ Valve manifold and Input Unit can be connected around the GW (Gateway) Unit.
- ★ Number of inputs/outputs = 128 points/128 points. The number of outputs (solenoids) per branch is 32 points.
- ★ Number of valve manifold connections = Max. 8 Units, Number of Input Unit connections = Max. 8 Units, Branch cable length = Max. 20 m
- ★ Web server function (Valve operation test, connection diagnostic of Units, short-circuit diagnostic of input devices)
- ★ No need to set the address for the valve manifold and Input Unit.

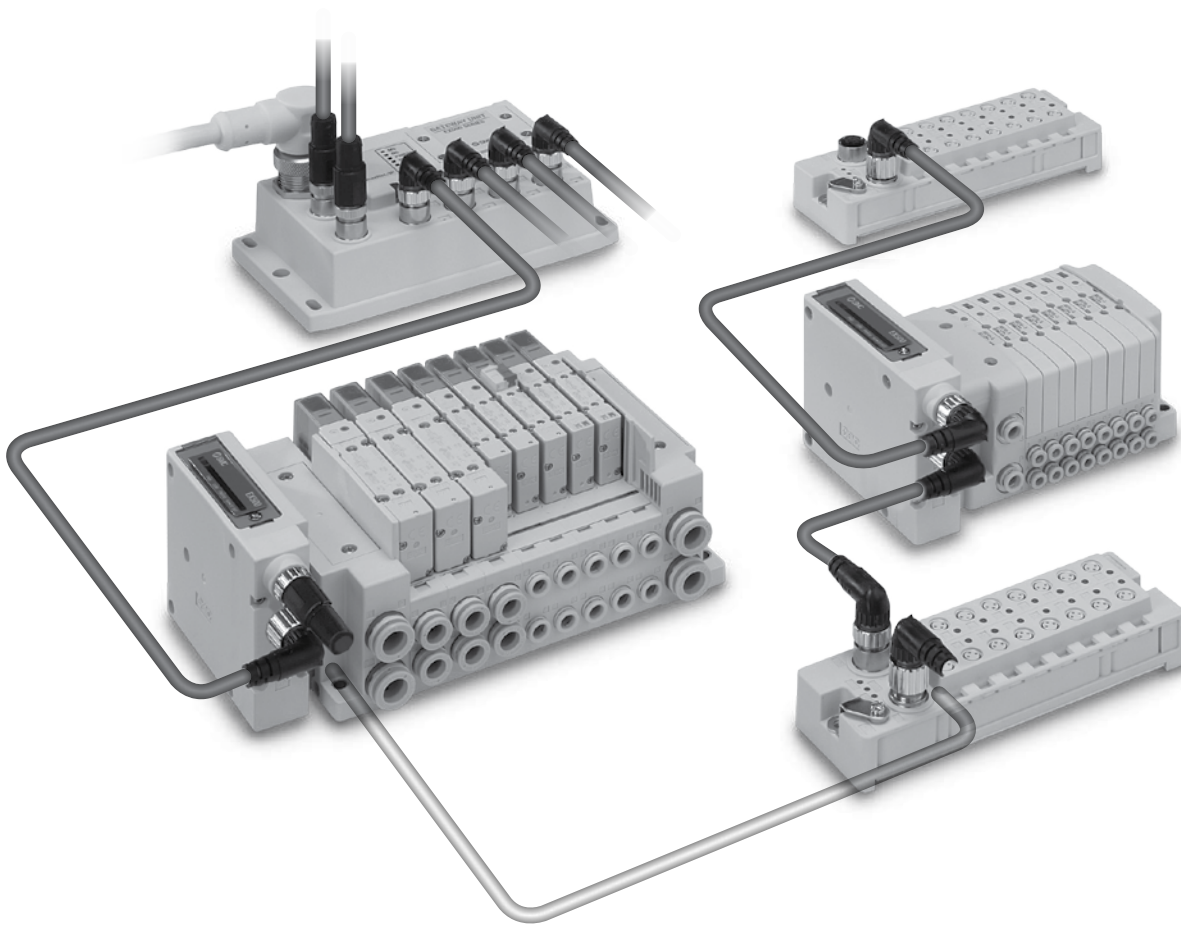

SY3000/5000/7000

Page 17



VQC1000/2000/4000/5000

Page 25

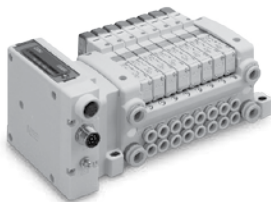

S0700

Page 37



SV1000/2000/3000

Page 40

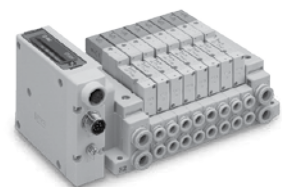



How to Order

EX500 – G EN2

Communication protocol

EN2	EtherNet/IP™
	(Input/Output = 128 points/128 points)

Specifications

Model		
Communication	Protocol	EtherNet/IP™ Note 1)
	Version	Volume 1 (Edition 3.14) Note 2) Volume 2 (Edition 1.15)
	Media	100BASE-TX
	Communication speed	10/100 Mbps (Automatic)
	Communication method	Full duplex/Half duplex (Automatic)
	Number of inputs/outputs (I/O occupation area)	128 inputs/128 outputs (20 bytes/20 bytes)
	Configuration file	EDS file Note 3)
	IP address setting range	Switch settings: 192.168.0.1 to 254 or 192.168.1.1 to 254, Through DHCP server: Optional address
	Device information	Vendor ID: 7 (SMC Corporation) Product type: 12 (Communication Adapter), Product code: 198
	Applicable function	DLR QuickConnect™ Web server
Power supply voltage	For input and control	24 VDC ±10%
	For valve	24 VDC +10%, -5%
Current consumption	For input and control	6.2 A or less (Max. 1.5 A per branch x 4 branches + GW Unit internal current consumption: 0.2 A or less)
	For output (valve)	4 A or less (Max. 1 A per branch x 4 branches)
Branch port	Number of branch ports	4 ports
	Number of inputs and outputs	32 inputs/32 outputs per branch
	Branch cable length	20 m or less per branch
Environment	Enclosure	IP65
	Operating temperature range	Operating: 14 to 122°F [-10 to 50°C] Stored: -4 to 140°F [-20 to 60°C] (No condensation)
	Operating humidity range	Operating, Stored: 35 to 85%RH (No condensation)
Standards	CE marking, UL (CSA), RoHS compliant	
Weight	550 g	
Enclosed parts	Seal cap (for M12 connector socket) 5 pcs.	

Note 1) Use a CAT5 or higher communication cable.

Note 2) Please note that the version is subject to change.

Note 3) Each file can be downloaded from SMC website, <http://www.smcworld.com>

Dimensions/Parts Description

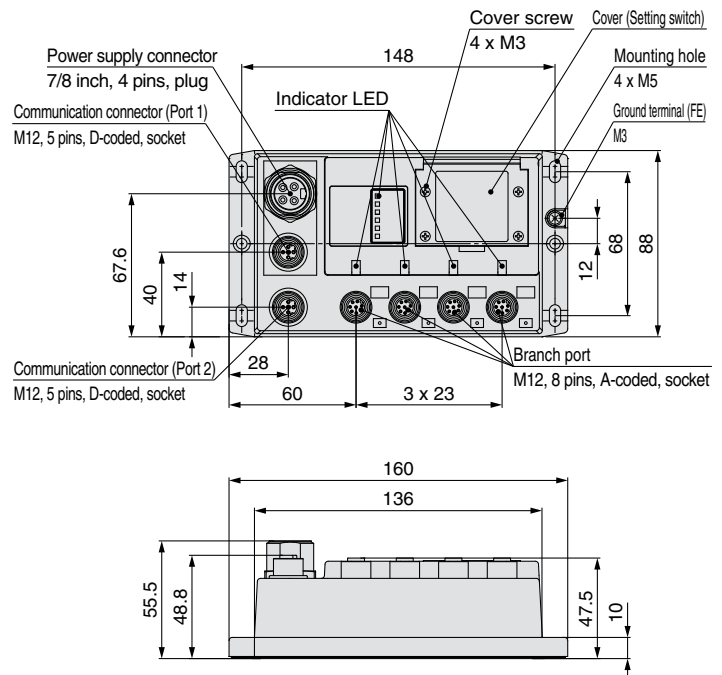

Series EX500

Gateway Decentralized System 2 (128 Points)

SI Unit



Output Unit for valve manifold connection

How to Order

EX500 – S103



Gateway Decentralized System 2

SY

VQC

S0700

SV

Specifications

		EX500-S103
Applicable valve		SY, VQC, S0700, SV
Output	Number of outputs	16/32 outputs (Switched by built-in setting switch)
	Output type	Source/PNP (Negative common)
	Rated voltage	24 VDC
	Supply current	With power supplied to GW Unit: Max. 1.0 A With external power* supplied: Max. 1.5 A
Internal current consumption		50 mA or less
Environment	Enclosure	IP67
	Operating temperature range	Operating: 14 to 122°F [-10 to 50°C], Stored: -4 to 140°F [-20 to 60°C] (No condensation)
	Operating humidity range	Operating, Stored: 35 to 85%RH (No condensation)
Standards		CE, UL (CSA), RoHS compliant
Weight		200 g
Enclosed parts		Seal cap (for M12 connector socket) 1 pc. Hexagon socket head cap screw (M3 x 30) 2 pcs.

* When an accessory, Y branch connector, is used.

Dimensions/Parts Description

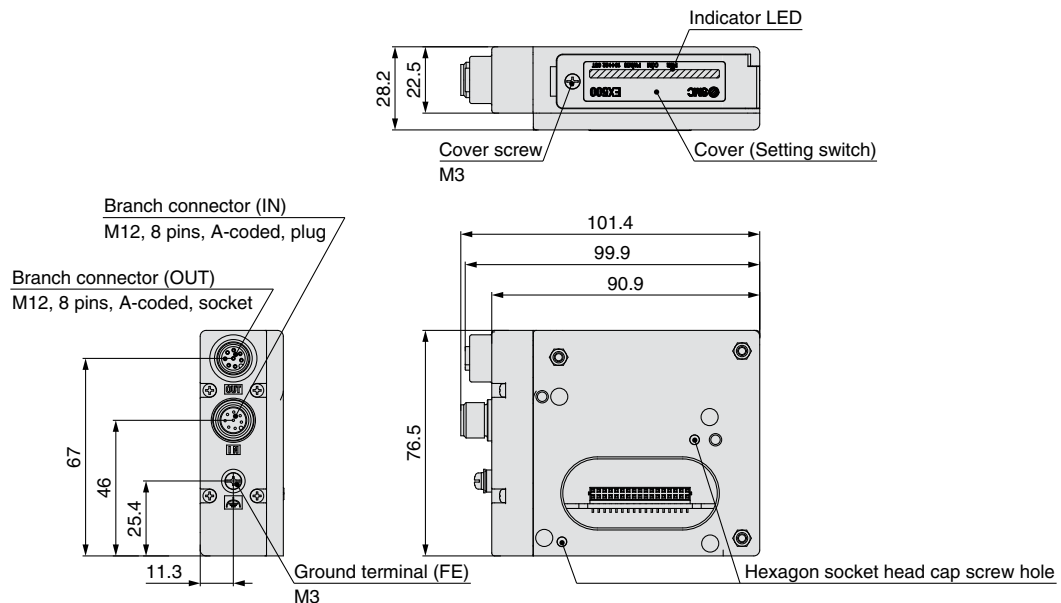

Input Unit



How to Order

EX500 – DXPA



Specifications

Model		EX500-DXPA
Input	Number of inputs	16 inputs
	Input type	PNP
	Rated voltage	24 VDC
	Supply current	Max. 1.3 A/Unit [Total of 8 connectors of even number must be Max. 0.65 A, 8 connectors of odd number must be Max. 0.65 A]
	Input ON voltage/Input ON current	11 V or more/Typ. 7 mA (at 24 VDC)
	Input OFF voltage/Input OFF current	5 V or less/1.5 mA or less
Internal current consumption		200 mA or less (when the input signal is ON)
Environment	Enclosure	IP67
	Operating temperature range	Operating: 14 to 122°F [-10 to 50°C], Stored: -4 to 140°F [-20 to 60°C] (No condensation)
	Operating humidity range	Operating, Stored: 35 to 85%RH (No condensation)
Standards		CE, UL (CSA), RoHS compliant
Weight		250 g
Enclosed parts		Seal cap (for M8 connector socket) 16 pcs. Seal cap (for M12 connector socket) 1 pc.

Dimensions/Parts Description

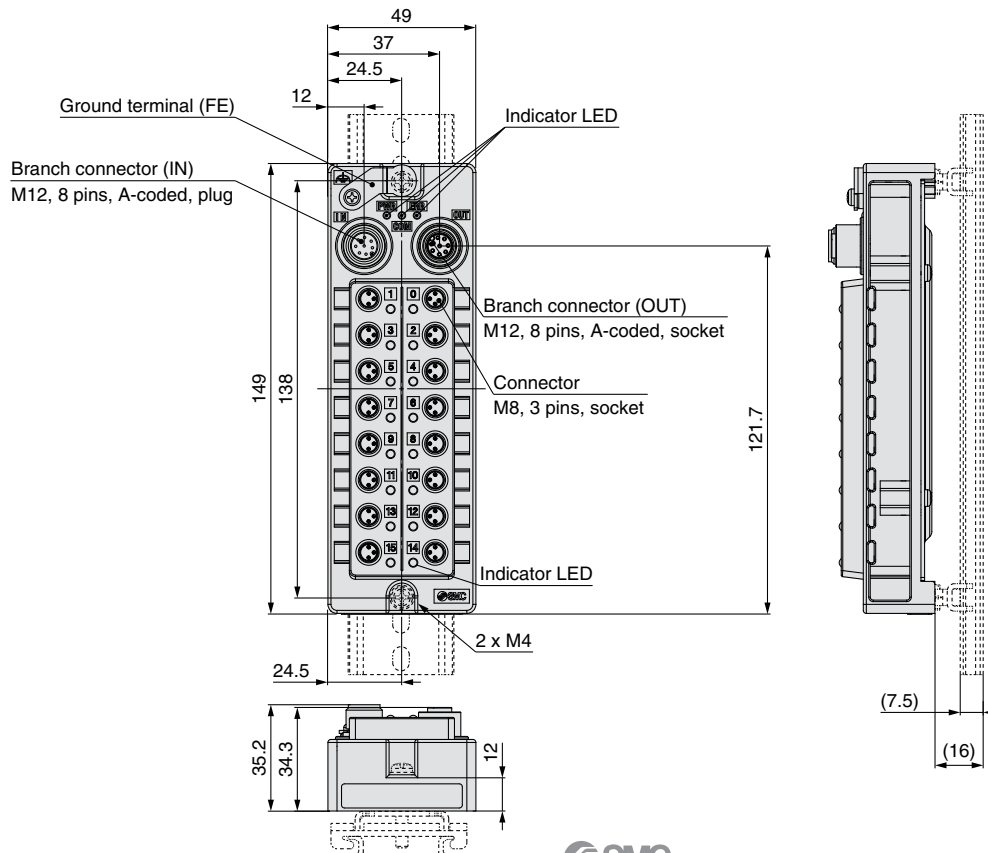

Gateway Decentralized System 2 (128 Points) Accessories

① Branch Cable

Connects the GW Unit and SI Unit or Input Unit.

EX500-AC 030 - SSPS

Cable length (L)

003	300 [mm]
005	500 [mm]
010	1000 [mm]
030	3000 [mm]
050	5000 [mm]
100	10000 [mm]

Connector specification

SSPS	Socket side: Straight, Plug side: Straight
SAPA	Socket side: Angle, Plug side: Angle

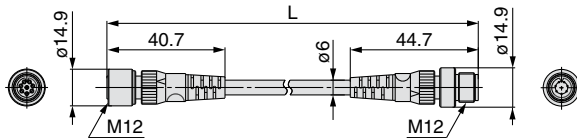

A-coded



Socket

A-coded



Plug

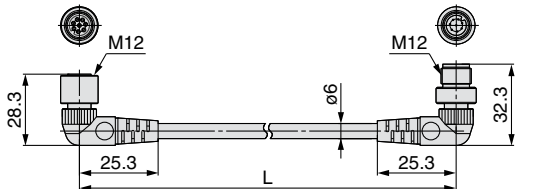

A-coded



Socket

A-coded



Plug

② Power Supply Cable

Supplies power to the GW Unit.

PCA-1416000

Connector specification, Cable length (L)

1415999	Straight 2 m
1415996	Straight 6 m
1416000	Angle 2 m
1415997	Angle 6 m

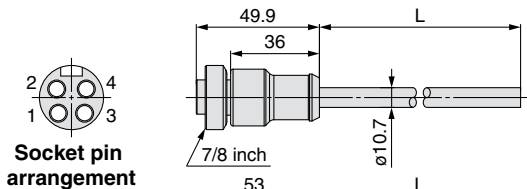

Socket pin arrangement

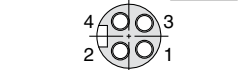
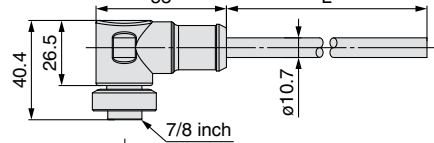

Socket pin arrangement

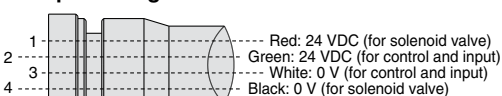

Connections

③ Communication Cable/Connector

Connects field bus to the GW Unit.

Cable with connector

PCA-1446566 SPEEDCON

Cable length

1446566	5000 [mm]
---------	-----------

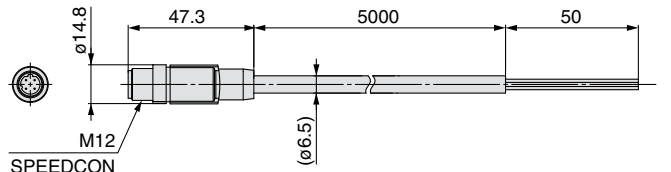

D-coded



Plug pin arrangement

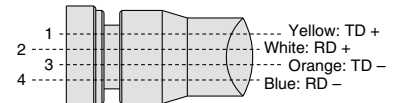

Connections

Field wireable connector

PCA-1446553

D-coded



Plug pin arrangement

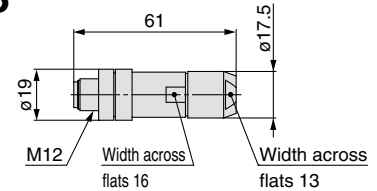

Applicable Cable

Cable O.D.	4.0 to 8.0 mm
Wire gauge (Stranded wire cross section)	0.14 to 0.34 mm ² /AWG26 to 22

Note) The table above shows the specifications for the applicable cable. Adaptation for the connector may vary on account of the conductor construction of the electric wire.

Cable with M12 ↔ RJ-45 connector

EX9-AC 020 EN - PSRJ

Cable length (L)

010	1000 [mm]
020	2000 [mm]
030	3000 [mm]
050	5000 [mm]
100	10000 [mm]

Connector specification

PSRJ	M12 plug (Straight) ↔ RJ-45 connector
------	------------------------------------------

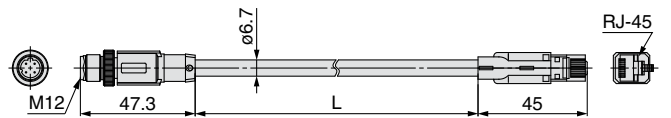

D-coded

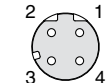

Plug pin arrangement

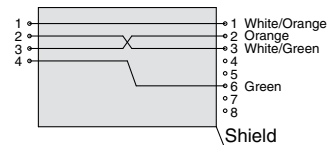

Connections

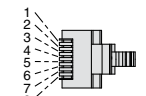

Plug pin arrangement

Series EX500

<Example of use>

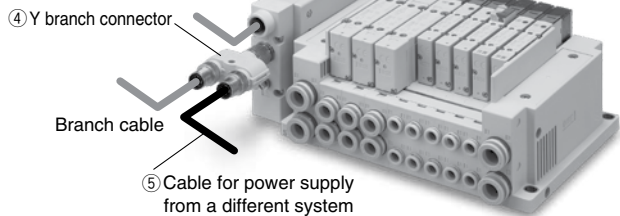

④ Y Branch Connector

Supplies separate power to valve manifold when it is connected to the SI Unit.

EX500-ACY01-S

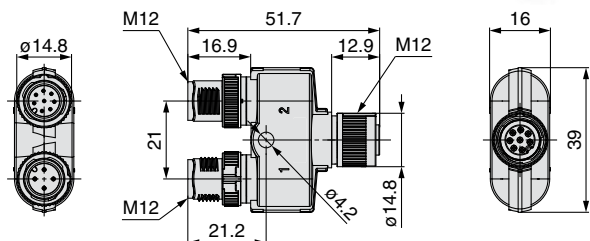

A-coded

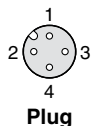

Pin Layout of the Cable for Power Supply from a Different System

1	24 VDC +10%, -5% (for solenoid valve)
2	0 VDC (for solenoid valve)
3	Unused
4	Unused

⑦ Marker (1 sheet, 88 pcs.)

Signal name of the input device such as a switch can be written on the marker and installed to the Input Unit.

EX600-ZT1

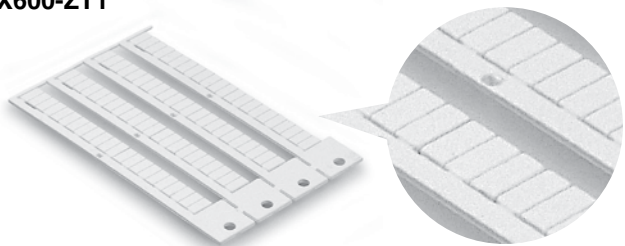

⑧ Seal Cap (10 pcs.)

Use with new connector. By using these waterproof caps, the new connector maintains IP65/67 enclosure.

EX9-AWES

For M8 connector socket

EX9-AWTS

For M12 connector socket



⑤ Cable for Power Supply from a Different System

Connect to Y branch connector to supply power.

EX500-AP050-S

Cable length (L)

010	1000 [mm]
050	5000 [mm]

Connector specification

S	Straight
A	Angle

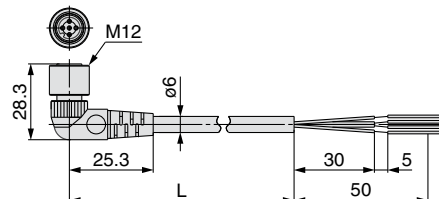
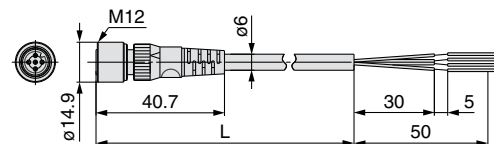

PCA-1401804

Cable length (L)

1401804	1500 [mm]
1401805	3000 [mm]
1401806	5000 [mm]

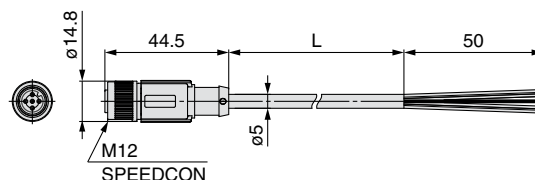

A-coded



Socket pin arrangement

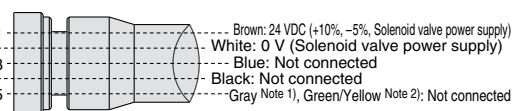

Connections

Note 1) For EX500-AP□-□
Note 2) For PCA-□

⑥ DIN Rail Bracket (2 pcs.)

Bracket for mounting the Input Unit to DIN rail.

EX500-ZMA1

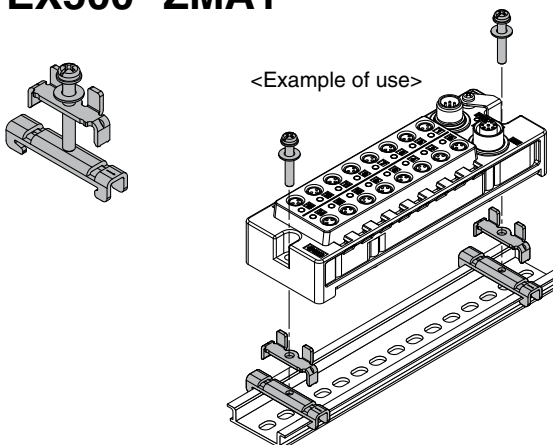

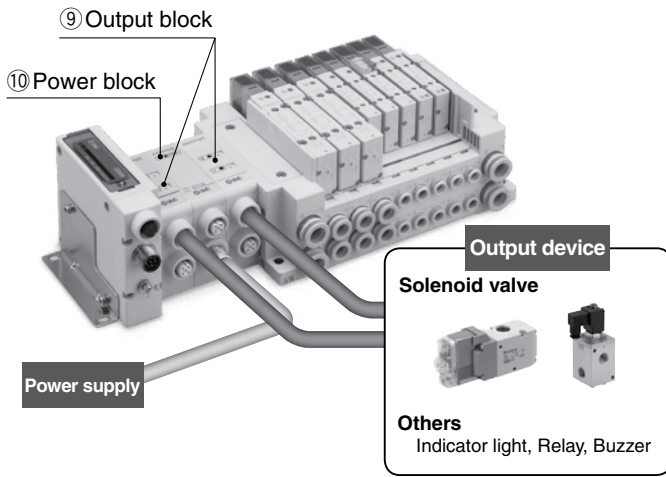

- Output devices other than valve manifold can be operated.
- By using the power block and output block for high watt load, operation up to 0.5 A/1 point can be performed.
- Possible to mount the output block and power block additionally between the SI Unit and the valve (The surplus I/O points are used).
- 2 point outputs per output block (M12 connector)

You are requested to connect it to an SI Unit and a valve manifold. For detailed specifications, refer to the Operation Manual that can be downloaded from SMC website, <http://www.smcworld.com>

9 Output Block

EX9 – OE T 1

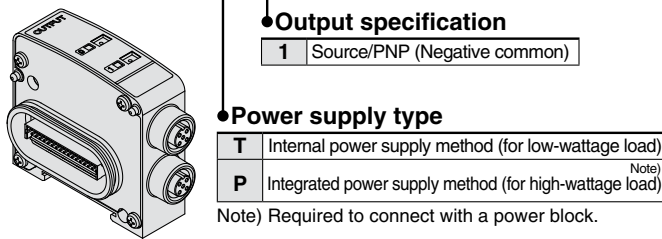

Dimensions/Parts Description

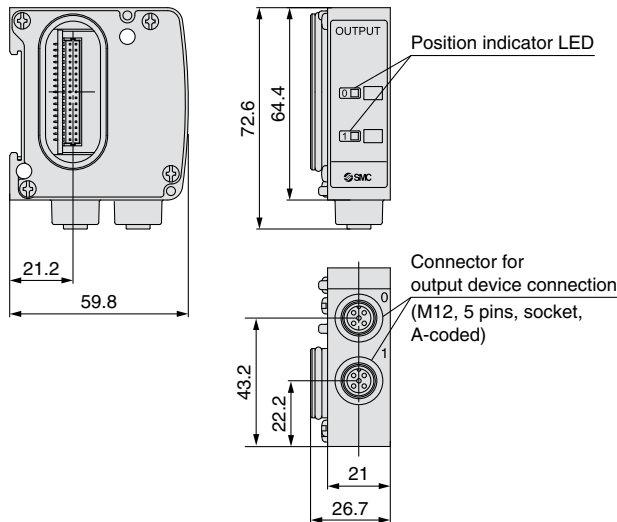

Specifications

Model	EX9-OET1	EX9-OEP1	
Internal current consumption	40 mA or less		
Output type	Source/PNP (Negative common)		
Number of outputs	2 outputs		
Output	Power supply method	Internal power supply method / Integrated power supply method (Power block: supplied from EX9-PE1)	
	Output device supply voltage	24 VDC	
	Output device supply current	Max. 42 mA/point (1.0 W/point)	Max. 0.5 A/point (12 W/point)
Environment	Enclosure	IP67	
	Operating temperature range	14 to 122°F [-10 to 50°C]	
	Operating humidity range	35 to 85%RH (No condensation)	
Standards	CE marking, UL (CSA), RoHS compliant		
Weight	120 g		

10 Power Block

EX9 – PE1

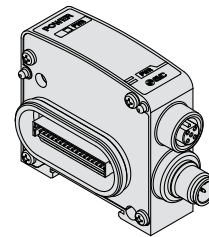

Dimensions/Parts Description

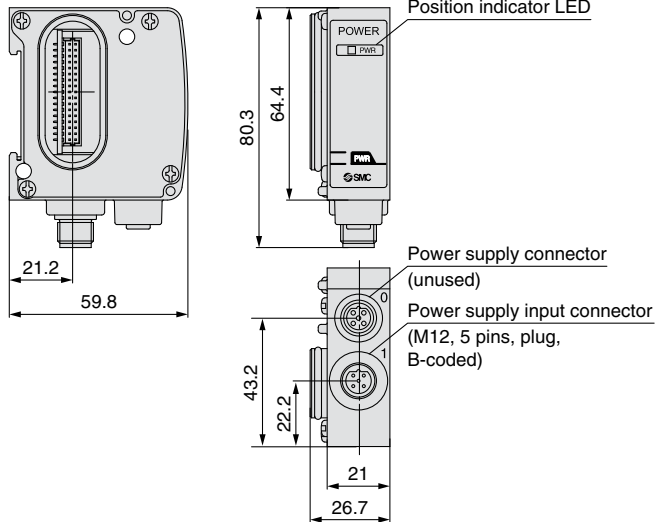

Specifications

Model	EX9-PE1	
Connection block	Output block for high wattage load	
Connection block stations	Output block: Max. 8 stations	
Power supply for output and internal control	Power supply voltage	22.8 to 26.4 VDC
	Internal current consumption	20 mA or less
Supply current	Max. 3.1 A <small>Note)</small>	
Environment	Enclosure	IP67
	Operating temperature range	14 to 122°F [-10 to 50°C]
	Operating humidity range	35 to 85%RH (No condensation)
Standards	CE marking, UL (CSA), RoHS	
Weight	120 g	
Enclosed parts	Seal cap (for M12 connector) 1 pc.	

Note) When using with 3.0 to 3.1 A, the ambient temperature should not exceed 104°F [40°C], and do not bundle the cable.

Series EX500

⑪ Connector for Output Block Wiring

Field wireable connects the output device to the output block.

PCA-1557743

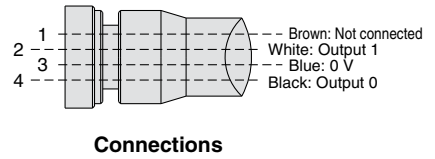
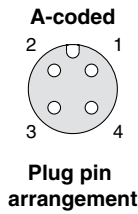
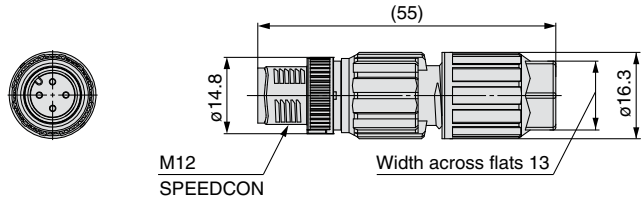

Applicable Cable

Cable O.D.	3.5 to 6.0 mm
Wire gauge (Stranded wire cross section)	0.14 to 0.34 mm ² /AWG26 to 22
Core wire diameter (Including insulating material)	0.7 to 1.3 mm

PCA-1557756

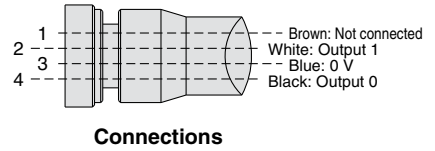
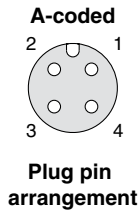
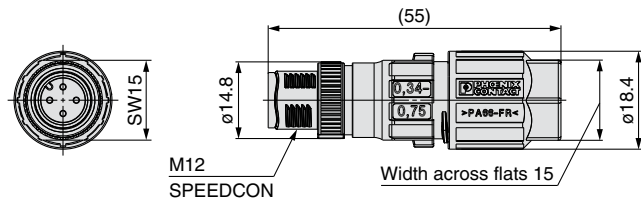

Applicable Cable

Cable O.D.	4.0 to 8.0 mm
Wire gauge (Stranded wire cross section)	0.34 to 0.75 mm ² /AWG22 to 18
Core wire diameter (Including insulating material)	1.3 to 2.5 mm

⑫ Power Supply Cable for Power Block

Supplies power to the power block.

EX9-AC 050-1

Cable length (L)

010	1000 [mm]
030	3000 [mm]
050	5000 [mm]

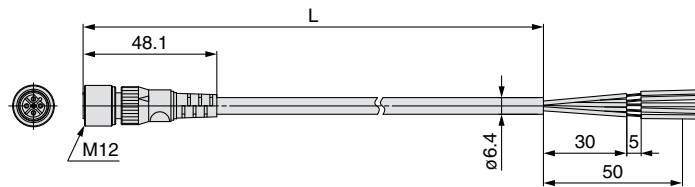

PCA-1401807

Cable length (L)

1401807	1500 [mm]
1401808	3000 [mm]
1401809	5000 [mm]

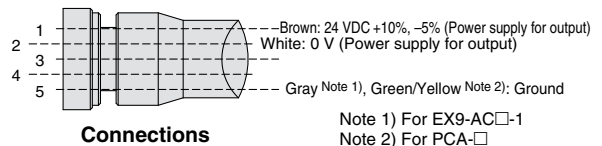
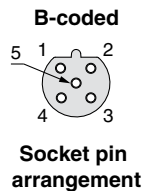
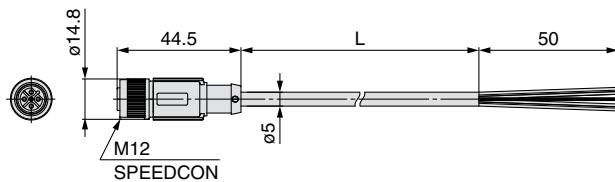

⑬ End Plate

Use when the output block is not used and the valve manifold is not connected.

EX9 – EA03

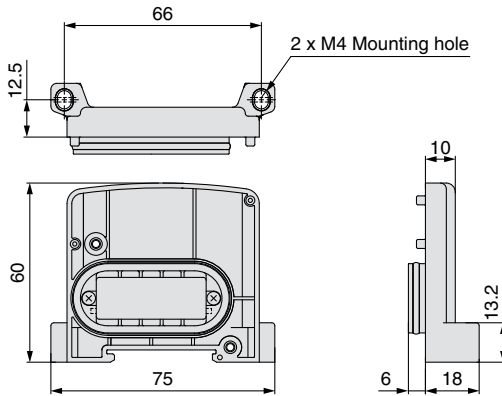

<Example of use>



⑭ Bracket Plate

A reinforcing brace used to mount output block or power block onto the SI Unit. To prevent connection failure between products due to deflection, use this bracket plate whenever output block or power block is mounted.

EX9 – BP1

Dimensions

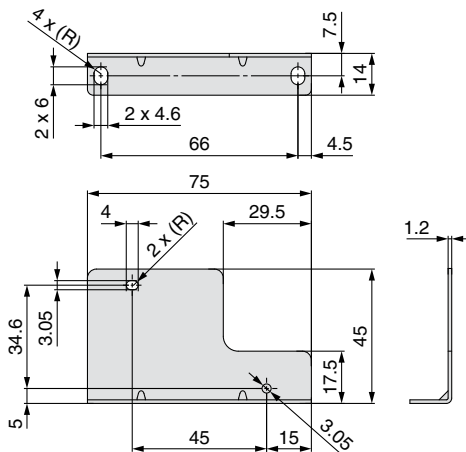

<Example of use>

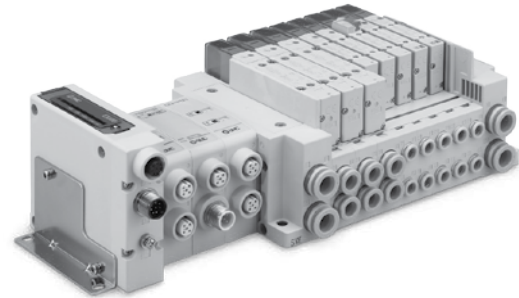

Accessory

Description	Quantity
Hexagon socket head cap screw (M3 x 35)	2

Gateway Decentralized System 2

5 Port Solenoid Valve Series SV1000/2000/3000



For detailed specifications, Common Precautions and Specific Product Precautions, refer to the **WEB catalog** or the SV series catalog (CAT. NAS11-81).

How to Order Manifold



① Series

1	SV1000
2	SV2000
3	SV3000

② SI Unit (Number of outputs, Output polarity, Max. number of valve stations)

0	Without SI Unit
A3N	32 outputs ^{Note 1)} , Negative common, 1 to 16 stations (20 stations ^{Note 2)})

Note 1) 16 outputs can be set by switching the built-in setting switch.

Note 2) (): Maximum number of stations for mixed single and double wiring.

③ Valve stations

Stations	Note
02	2 stations Double wiring ^{Note 1)}
⋮	
16	
02	2 stations Mixed wiring, Specified layout ^{Note 2)} (Available up to 32 solenoids)
⋮	
20	

Note 1) Double wiring: single, double, 3-position and 4-position valves can be used on all manifold stations.

Use of a single solenoid will result in an unused control signal. If this is not desired, order with a specified layout.

Note 2) Specified layout: Indicate the wiring specifications on the manifold specification sheet. (Note that double, 3-position and 4-position valves cannot be used where single wiring has been specified.)

④ P, E port entry

U	U side (2 to 10 stations)
D	D side (2 to 10 stations)
B	Both sides (2 to 20 stations)

⑤ SUP/EXH block assembly

Nil	Internal pilot
S	Internal pilot, Built-in silencer ^{Note)}
R	External pilot
RS	External pilot, Built-in silencer ^{Note)}

Note) When the built-in silencer type is used, keep the exhaust port from coming in direct contact with water or other liquids.

⑦ Mounting

Nil	Direct mounting
D	With DIN bracket, DIN rail with standard length
D0	With DIN bracket, without DIN rail
D3 ^{Note)}	With DIN bracket, DIN rail for 3 stations
⋮	⋮
D20 ^{Note)}	With DIN bracket, DIN rail for 20 stations

Note) Specify a longer rail than the length of valve stations.

* If the DIN rail must be mounted without an SI Unit, select "D0" and order the DIN rail separately. Refer to L3 of the dimensions for the DIN rail length. For the DIN rail part number, refer to the **WEB catalog** or the SV series catalog (CAT. NAS11-81).

⑥ A, B port size

Metric size

	A, B port	P, E port	Applicable series
C3	ø3.2 One-touch fitting	ø8 One-touch fitting	SV1000
C4	ø4 One-touch fitting		
C6	ø6 One-touch fitting	ø10 One-touch fitting	SV2000
C4	ø4 One-touch fitting		
C6	ø6 One-touch fitting	ø12 One-touch fitting	SV3000
C8	ø8 One-touch fitting		
C6	ø6 One-touch fitting	ø12 One-touch fitting	SV3000
C8	ø8 One-touch fitting		
C10	ø10 One-touch fitting	ø12 One-touch fitting	
M ^{Note)}	A, B port mixed		

Inch size

	A, B port	P, E port	Applicable series
N1	ø1/8" One-touch fitting	ø5/16" One-touch fitting	SV1000
N3	ø5/32" One-touch fitting		
N7	ø1/4" One-touch fitting	ø3/8" One-touch fitting	SV2000
N3	ø5/32" One-touch fitting		
N7	ø1/4" One-touch fitting	ø3/8" One-touch fitting	SV3000
N9	ø5/16" One-touch fitting		
N7	ø1/4" One-touch fitting	ø3/8" One-touch fitting	SV3000
N9	ø5/16" One-touch fitting		
N11	ø3/8" One-touch fitting	ø3/8" One-touch fitting	
M ^{Note)}	A, B port mixed		

Note) Indicate the sizes on the manifold specification sheet.

* The X and PE port size of external pilot type [R, RS] are ø4 (mm) or ø5/32" (inch) for the SV1000/2000 series, and ø6 (mm) or ø1/4" (inch) for the SV3000 series.

Series SV1000/2000/3000

How to Order Valves

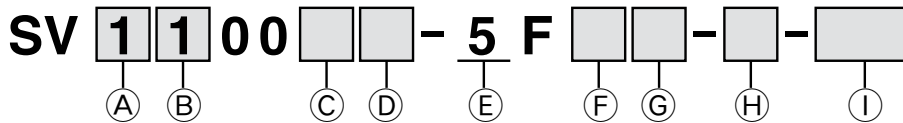

A Series

1	SV1000
2	SV2000
3	SV3000

B Type of actuation

1	2-position single
2	2-position double
3	3-position closed center
4	3-position exhaust center
5	3-position pressure center
A (Note)	4-position dual 3-port valve (N.C./N.C.)
B (Note)	4-position dual 3-port valve (N.O./N.O.)
C (Note)	4-position dual 3-port valve (N.C./N.O.)

Note) Select the SV1000 or SV2000 series for the 4-position dual 3-port valve.

* Select the internal pilot type for the 4-position dual 3-port valve.

C Pilot type

Nil	Internal pilot
R	External pilot

D Back pressure check valve

Nil	None
K	Built-in

* Built-in back pressure check valve type is applicable to the SV1000 series only.

* The product with a back pressure check valve is not available for 3-position valves.

* Refer to the **WEB catalog** for built-in back pressure check valve type.

E Rated voltage

5	24 VDC
----------	--------

F Light/surge voltage suppressor

U	With light/surge voltage suppressor
R	Without light, with surge voltage suppressor

G Manual override

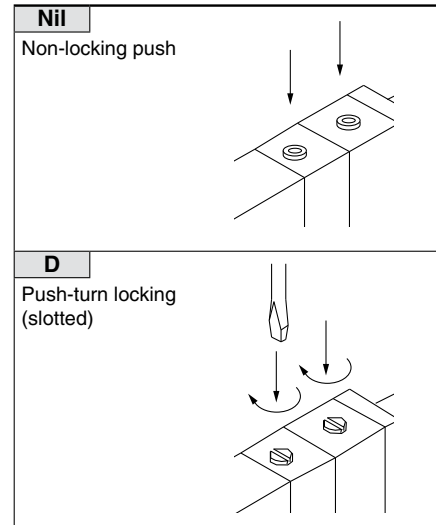

H Manifold block

If stations are to be added, order the product with manifold block.
(For details, refer to the **WEB catalog**.)

I Made to Order

Nil	—
X90	Main valve fluororubber specification (For details, refer to the WEB catalog .)

How to Order Manifold Assembly

Example

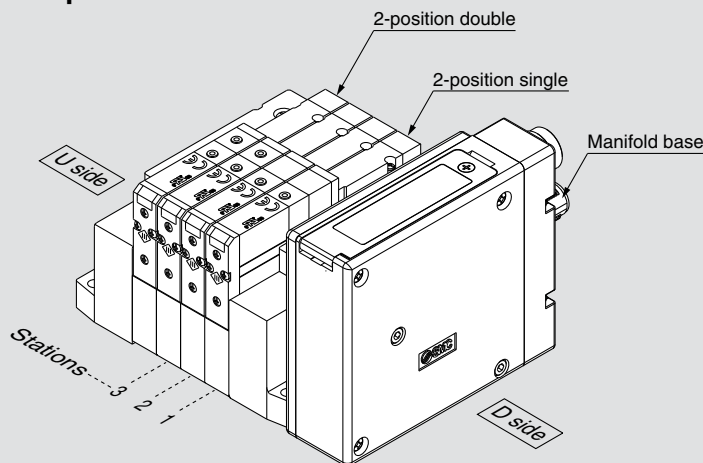

SS5V1-W10S1A3ND-04B-C6.....1 set (Manifold base part number)
 * SV1100-5FU.....2 sets (2-position single part number)
 * SV1200-5FU.....2 sets (2-position double part number)

The asterisk denotes the symbol for assembly.
 Prefix it to the part numbers of the valve etc.

- The valve arrangement is numbered as the 1st station from the D side.
- Under the manifold base part number, state the valves to be mounted in order from the 1st station as shown in the figure above. If the arrangement becomes complicated, specify on the manifold specification sheet.

Dimensions

Tie-rod Base Series SV1000

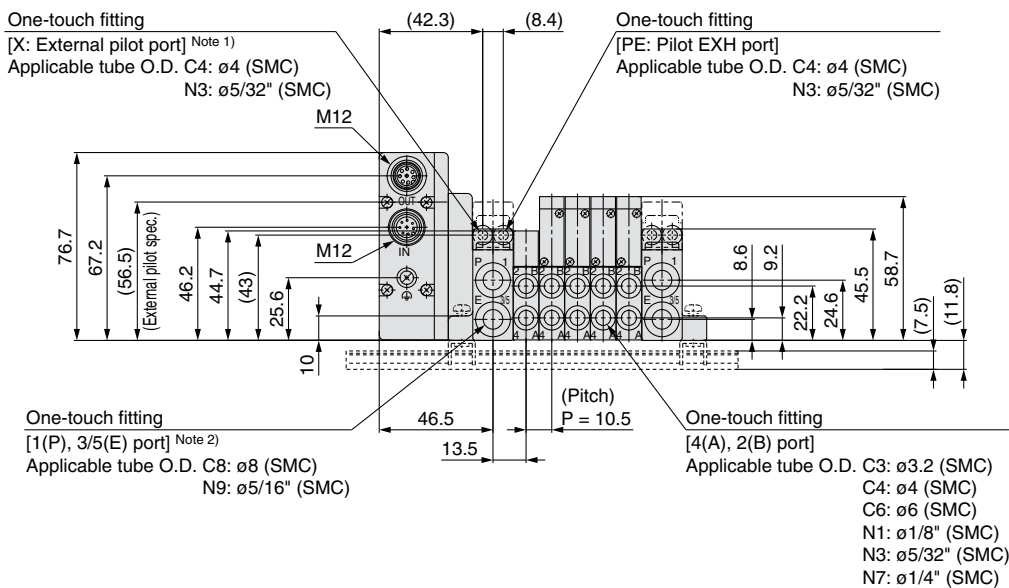
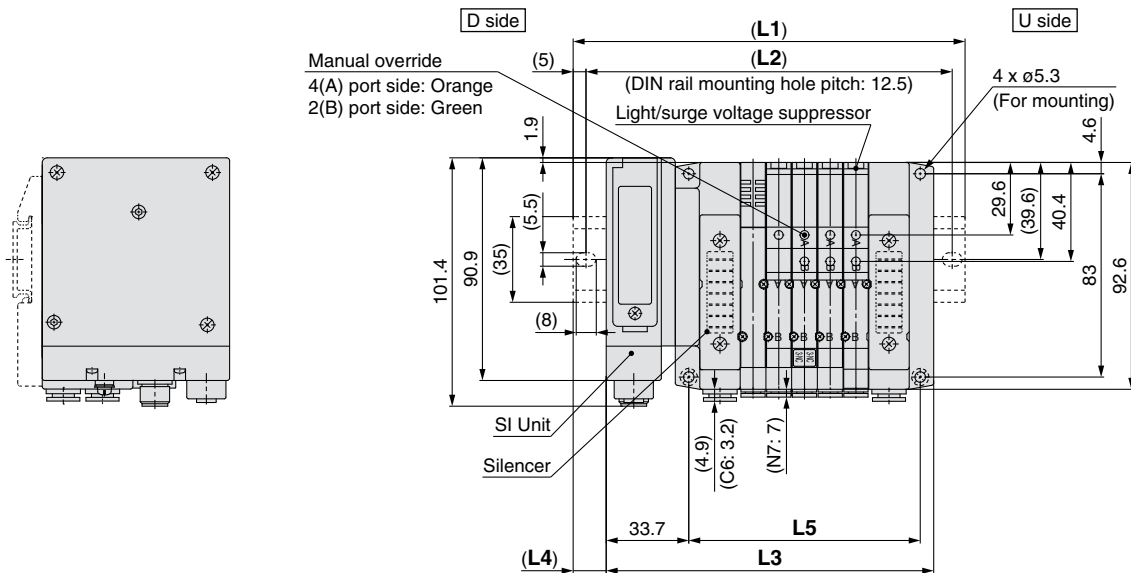

Note 1) External pilot port positions and silencer discharge port positions are the same as P, E port outlet positions.
Note 2) When P, E port outlets are indicated on the U side or D side, the P, E ports on the opposite side are plugged.

L: DIN Rail Overall Length

n: Stations

L \ n	2	3	4	5	6	7	8	9	10	11	12	13	14	15	16	17	18	19	20
L1	135.5	148	148	160.5	173	185.5	198	210.5	210.5	223	235.5	248	260.5	273	273	285.5	298	310.5	323
L2	125	137.5	137.5	150	162.5	175	187.5	200	200	212.5	225	237.5	250	262.5	262.5	275	287.5	300	312.5
L3	102.2	112.7	123.2	133.7	144.2	154.7	165.2	175.7	186.2	196.7	207.2	217.7	228.2	238.7	249.2	259.7	270.2	280.7	291.2
L4	16.5	17.5	12.5	13.5	14.5	15.5	16.5	17.5	12	13	14	15	16	17	12	13	14	15	16
L5	63	73.5	84	94.5	105	115.5	126	136.5	147	157.5	168	178.5	189	199.5	210	220.5	231	241.5	252

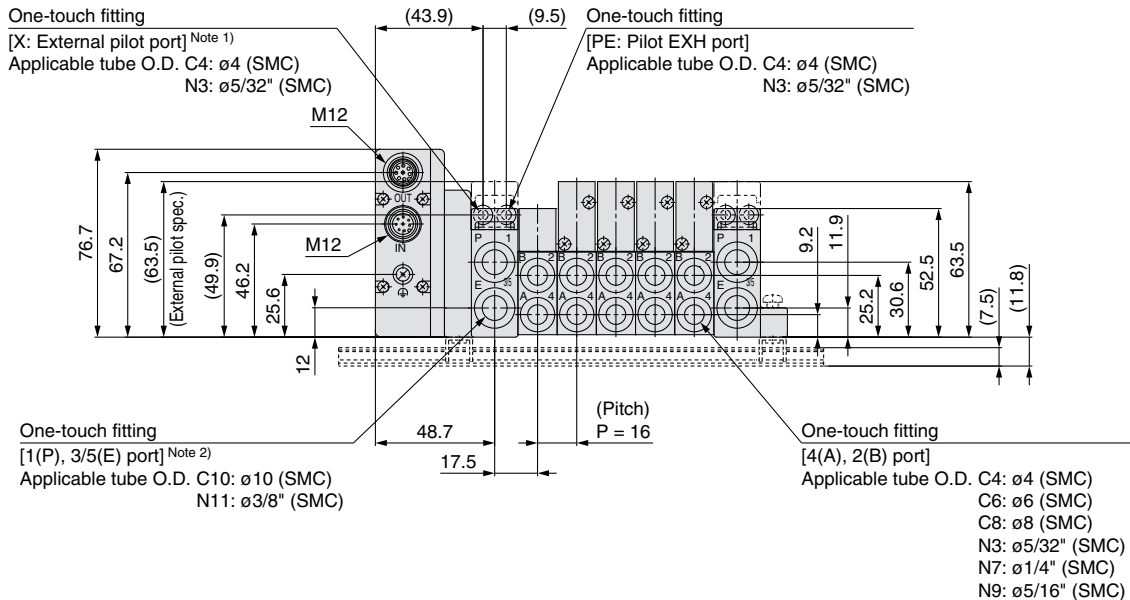
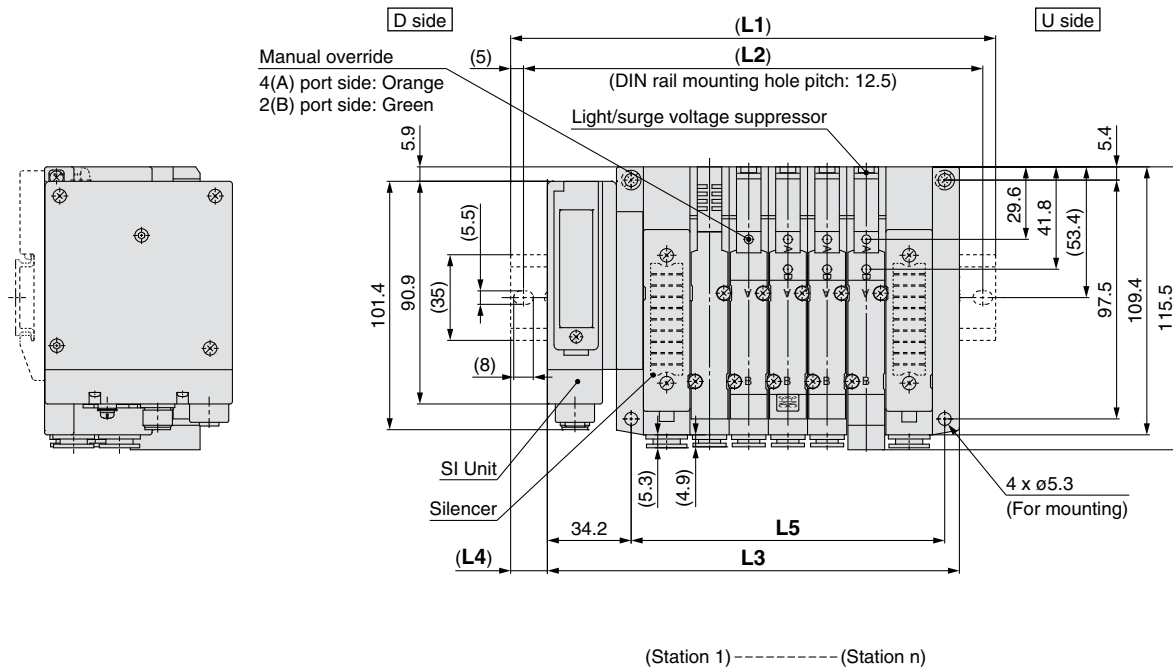

Note 1) External pilot port positions and silencer discharge port positions are the same as P, E port outlet positions.
Note 2) When P, E port outlets are indicated on the U side or D side, the P, E ports on the opposite side are plugged.

L: DIN Rail Overall Length

n: Stations

L \ n	2	3	4	5	6	7	8	9	10	11	12	13	14	15	16	17	18	19	20
L1	148	160.5	185.5	198	210.5	235.5	248	260.5	273	298	310.5	323	335.5	360.5	373	385.5	410.5	423	435.5
L2	137.5	150	175	187.5	200	225	237.5	250	262.5	287.5	300	312.5	325	350	362.5	375	400	412.5	425
L3	120.2	136.2	152.2	168.2	184.2	200.2	216.2	232.2	248.2	264.2	280.2	296.2	312.2	328.2	344.2	360.2	376.2	392.2	408.2
L4	14	12	16.5	15	13	17.5	16	14	12.5	17	15	13.5	11.5	16	14.5	12.5	17	15.5	13.5
L5	80	96	112	128	144	160	176	192	208	224	240	256	272	288	304	320	336	352	368

Dimensions

Tie-rod Base **Series SV3000**

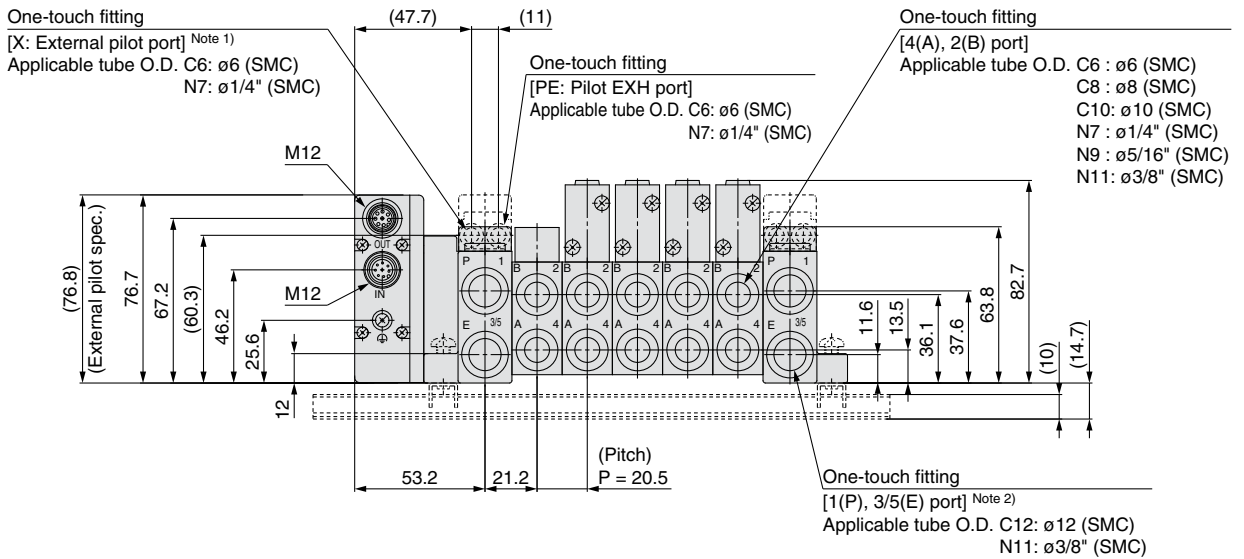
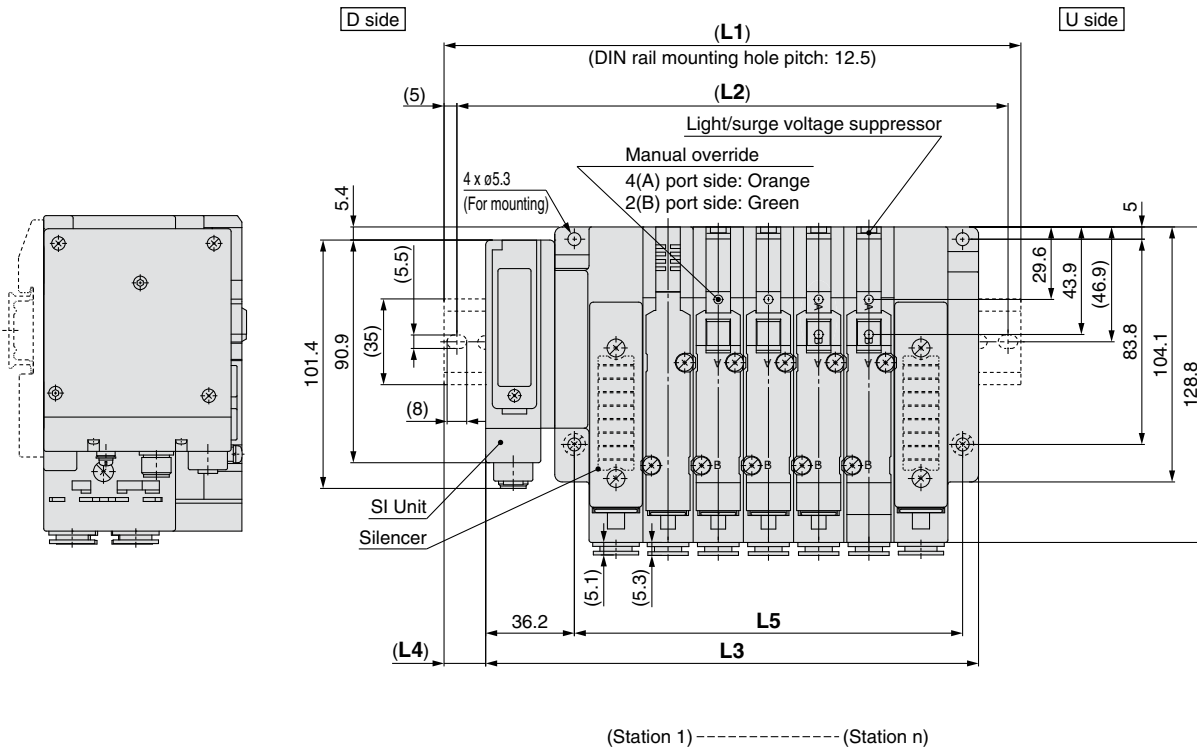

Note 1) External pilot port positions and silencer discharge port positions are the same as P, E port outlet positions.
 Note 2) When P, E port outlets are indicated on the U side or D side, the P, E ports on the opposite side are plugged.

L: DIN Rail Overall Length

n: Stations

L \ n	2	3	4	5	6	7	8	9	10	11	12	13	14	15	16	17	18	19	20
L1	173	185.5	210.5	235.5	248	273	298	310.5	335.5	348	373	398	410.5	435.5	460.5	473	498	523	535.5
L2	162.5	175	200	225	237.5	262.5	287.5	300	325	337.5	362.5	387.5	400	425	450	462.5	487.5	512.5	525
L3	139.7	160.2	180.7	201.2	221.7	242.2	262.7	283.2	303.7	324.2	344.7	365.2	385.7	406.2	426.7	447.2	467.7	488.2	508.7
L4	16.5	12.5	15	17	13	15.5	17.5	13.5	16	12	14	16.5	12.5	14.5	17	13	15	17.5	13.5
L5	97	117.5	138	158.5	179	199.5	220	240.5	261	281.5	302	322.5	343	363.5	384	404.5	425	445.5	466



Series *EX500*

Precautions on Mixed Usage of Gateway Decentralized System 2 (128 Points) and Gateway Decentralized System (64 Points)

		GW Unit	
		Gateway Decentralized System 2 (128 points) • EX500-GEN2	Gateway Decentralized System (64 points) • EX500-GDN1 • EX500-GPR1A
SI Unit Input Unit	Gateway Decentralized System 2 (128 points) • EX500-S103 • EX500-DX□□	Usable	Usable Same functions of Gateway Decentralized System (64 points)
	Gateway Decentralized System (64 points) • EX500-S001 • EX500-Q001/002 • EX500-Q101/102 • EEX500-IB1-□ (EX500-IB1)	Usable Same functions of Gateway Decentralized System (64 points)	Usable

Series EX500

Gateway Decentralized System (64 Points)

- ★ Valve manifold and Input Unit can be connected around the GW (Gateway) Unit.
- ★ Compatible with various protocols by replacing the GW Unit.
- ★ Number of inputs/outputs = 64 points/64 points. The number of outputs (solenoids) per branch is 16 points.
- ★ Number of valve manifold connections = Max. 4 Units, Number of Input Unit connections = Max. 4 Units, Cable length = Max. 10 m
- ★ No need to set the address for the valve manifold and Input Unit.

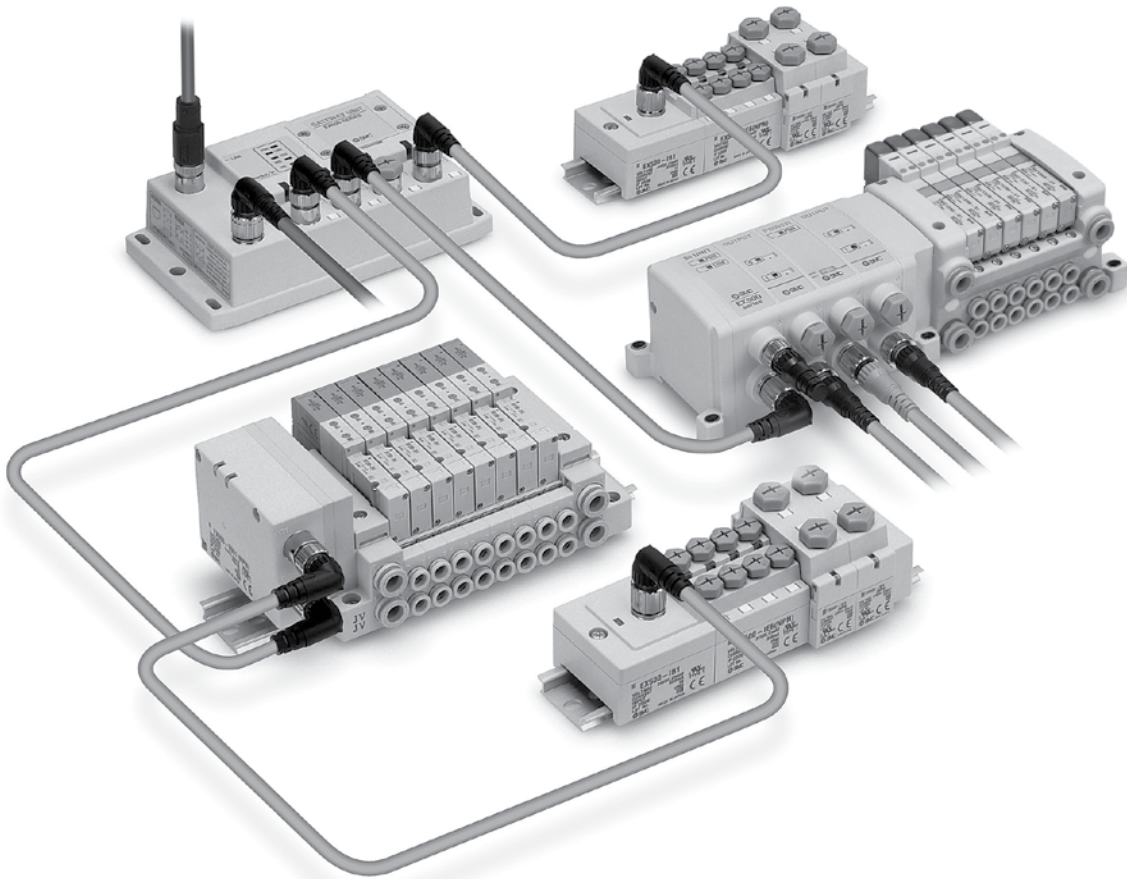

SY3000/5000/7000	Page 57
VQC1000/2000/4000/5000	Page 65
S0700	Page 77
SV1000/2000/3000/4000	Page 80

Gateway Decentralized System (64 Points)

GW Unit



How to Order

EX500 – G DN1

Communication protocol

DN1	DeviceNet™ (Input/Output = 64 points/64 points)
PR1A	PROFIBUS DP (Input/Output = 64 points/64 points)



Specifications

Model	EX500-GDN1	EX500-GPR1A	
Communication	Protocol	DeviceNet™	PROFIBUS DP
	Version (Note 1)	Release 2.0	DP-V0
	Communication speed	125 k/250 k/500 kbps	9.6 k/19.2 k/45.45 k/ 93.75 k/187.5 k/500 k/ 1.5 M/3 M/6 M/12 Mbps
	Configuration file (Note 2)	EDS file	GSD file
	Number of inputs/outputs (I/O occupation area)	64 inputs/64 outputs (8 bytes/8 bytes)	
	Terminating resistor	Not provided	Built into the Unit
Power supply voltage	For control	11 to 25 VDC (Supplied by DeviceNet™ circuit, 50 mA or less)	24 VDC ±10%
	For input device	24 VDC ±10%	
	For valve	24 VDC +10%, -5%	
Current consumption	For input and control	3.0 A or less (Max. 0.7 A per branch x 4 branches + GW Unit internal current consumption: 0.2 A or less)	
	For valve	3.0 A or less (Max. 0.75 A per branch x 4 branches)	
Branch port	Number of branch ports	4 ports	
	Number of inputs and outputs	16 inputs/16 outputs per branch	
	Branch cable length	5 m or less between connected devices (10 m or less per branch)	
Environment	Enclosure	IP65	
	Operating temperature range	Operating: 41 to 113°F [5 to 45°C] Stored: -13 to 158°F [-25 to 70°C] (No freezing and condensation)	
	Operating humidity range	Operating, Stored: 35 to 85%RH (No condensation)	
Standards	CE marking, UL (CSA), RoHS compliant		
Weight	470 g		
Enclosed parts	Seal cap (for M12 connector)	4 pcs.	
	Seal cap (for M12 connector)	5 pcs.	

Dimensions/Parts Description

EX500-GDN1 (DeviceNet™)

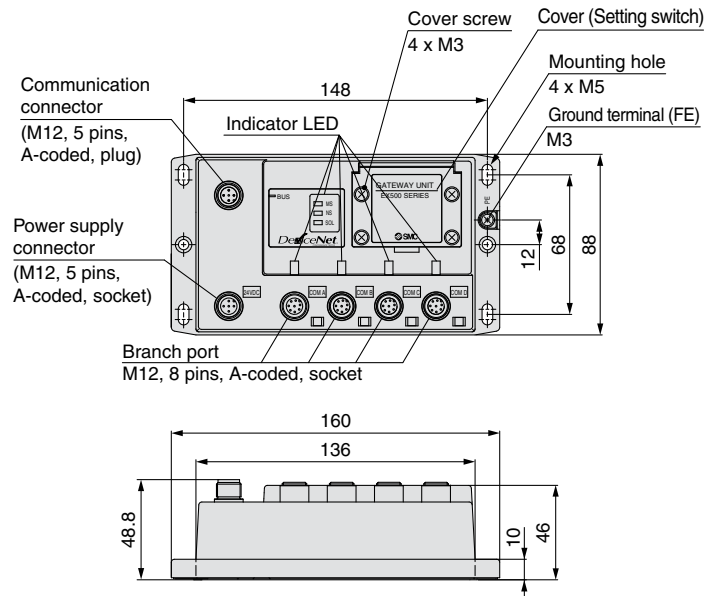

EX500-GPR1A (PROFIBUS DP)

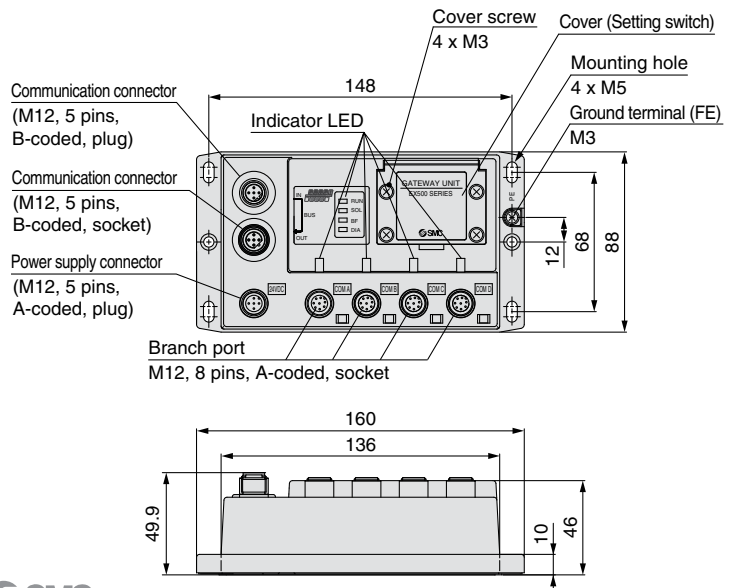

Note 1) Note that the version is subject to change.

Note 2) Each file can be downloaded from SMC website, <http://www.smcworld.com>

Series EX500

Gateway Decentralized System (64 Points) SI Unit

Output Unit for valve manifold connection



How to Order

For SV1000/2000/3000/4000

EX500 – S001

• Applicable valve:
Series SV

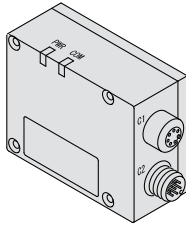

Specifications

Model		EX500-S001
Output	Number of outputs	16 outputs
	Output type	Sink/NPN (Positive common)
	Supply current	Max. 0.65 A
	Rated voltage	24 V
Internal current consumption		100 mA or less
Environment	Enclosure	IP67
	Operating temperature range	Operating: 41 to 113°F [5 to 45°C], Stored: -13 to 158°F [-25 to 70°C] (No freezing and condensation)
	Operating humidity range	Operating, Stored: 35 to 85%RH (No condensation)
Standards		CE marking, RoHS compliant
Weight		115 g
Enclosed parts		Seal cap (for M12 connector socket) 1 pc.

Dimensions/Parts Description

EX500-S001

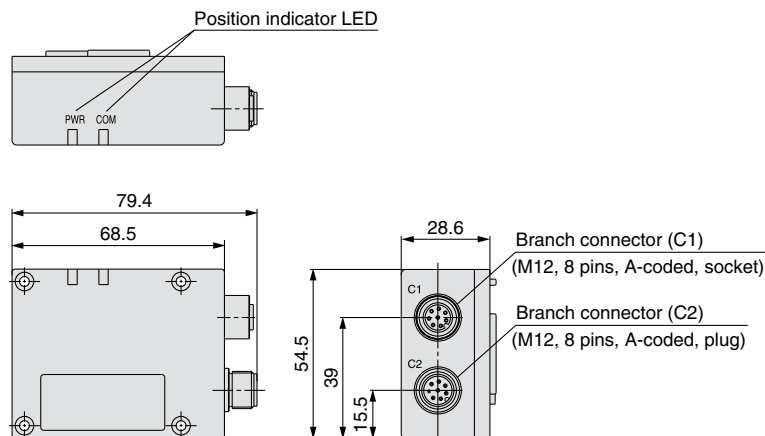

Gateway Decentralized System

SY

VQC

S0700

SV

Series EX500

For SY3000/5000/7000, VQC1000/2000/4000/5000, S0700

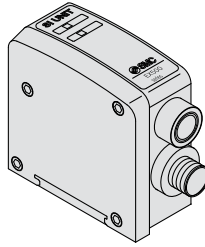

How to Order

EX500-Q001

Applicable valve:
Series SY/VQC/S0700

Output specification

0	NPN (Positive common)
1	PNP (Negative common)

SI Unit type

1	For without EX9 output block
2	For EX9 output block mounting

Specifications

Model		EX500-Q001	EX500-Q101	EX500-Q002	EX500-Q102
Output	Number of outputs	16 outputs			
	Output type	Sink/NPN (Positive common)	Source/PNP (Negative common)	Sink/NPN (Positive common)	Source/PNP (Negative common)
	Rated voltage	24 VDC			
	Supply current	Max. 0.75 A			
Internal current consumption		100 mA or less			
Environment	Enclosure	IP67			
	Operating temperature range	Operating: 41 to 113°F [5 to 45°C], Stored: -13 to 158°F [-25 to 70°C] (No freezing and condensation)			
	Operating humidity range	Operating, Stored: 35 to 85%RH (No condensation)			
Standards		CE marking, RoHS compliant			
Weight		105 g			
Enclosed parts		Seal cap (for M12 connector socket) 1 pc.			

Dimensions/Parts Description

EX500-Q□01

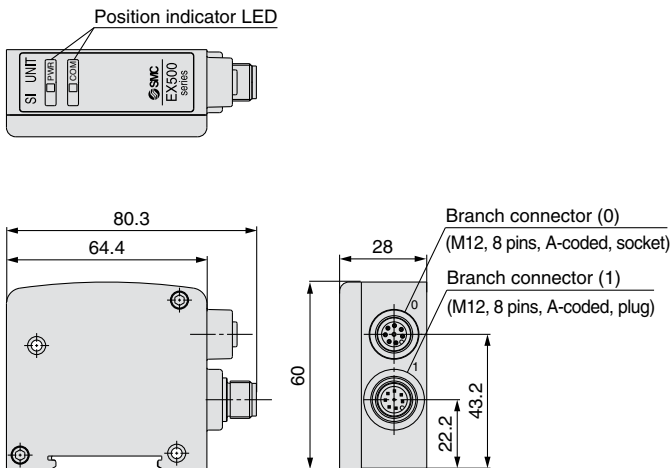

EX500-Q□02

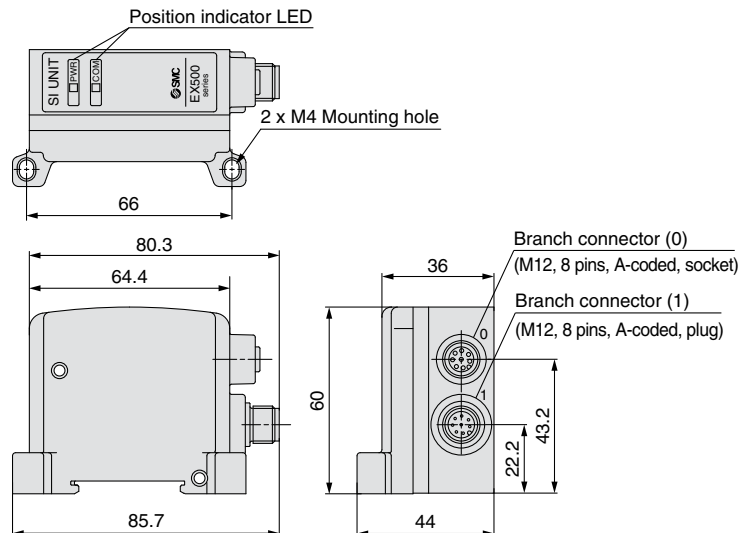

Series EX500

Gateway Decentralized System (64 Points) Input Manifold



How to Order Input Manifold

EEX500-IB1-E 8

Connector type	
E	M8 connector
T	M12 connector
M	M8, M12 mixed

Stations	
1	1 station
⋮	⋮
8	8 stations



How to Order Input Block

EX500-IE 1

Block type

1	M8 connector, 2 inputs, PNP specification
2	M8 connector, 2 inputs, NPN specification
3	M12 connector, 2 inputs, PNP specification
4	M12 connector, 2 inputs, NPN specification
5	M8 connector, 8 points integrated type, PNP specification
6	M8 connector, 8 points integrated type, NPN specification

Input Manifold

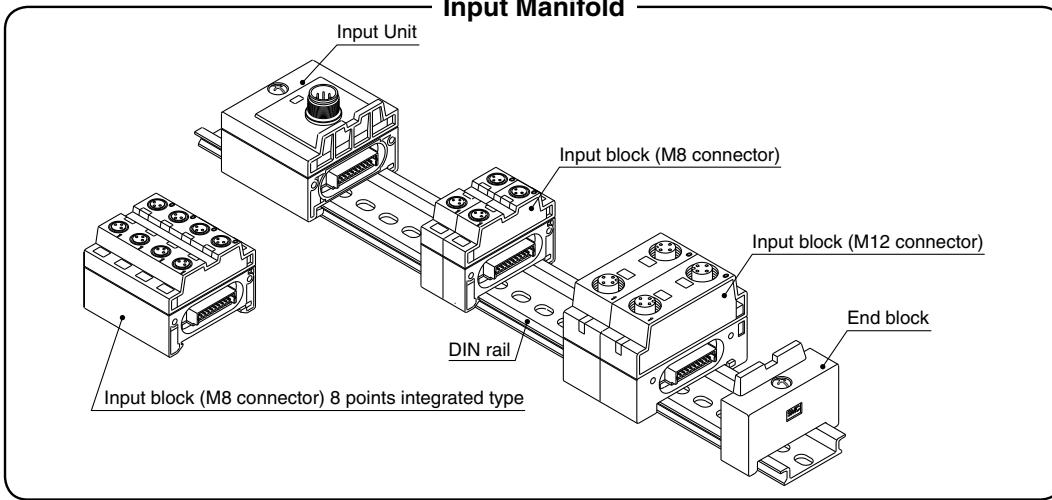

How to Order Input Manifold [Ordering Example]

When ordering an Input Unit manifold, enter the **Input manifold part number** + **Input block part number**.
Please mention the connected input block part numbers in order from the Input Unit side under the input manifold part number.
When an input block layout becomes complicated, indicate in the Input Unit manifold specification sheet.

* The **Input Unit**, **End block** and **DIN rail** are included in the input manifold.

Example 1) M8 Input block only

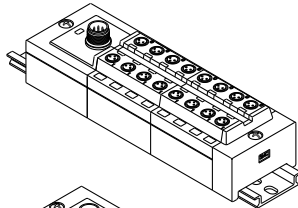

EEX500-IB1-E8 1 set

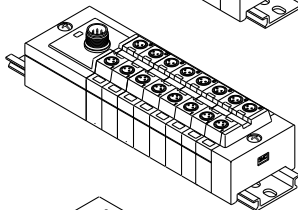

EEX500-IB1-E8 1 set
* EX500-IE1 8 sets

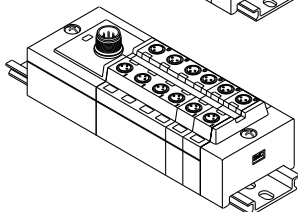

EEX500-IB1-E6 1 set
* EX500-IE5 1 set (Note)
* EX500-IE1 2 sets

Example 2) M12 Input block only

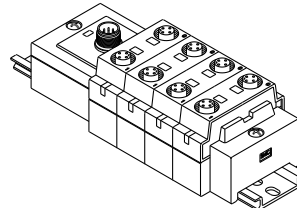

EEX500-IB1-T4 1 set
* EX500-IE4 4 sets

Example 3) M8, M12 mixed

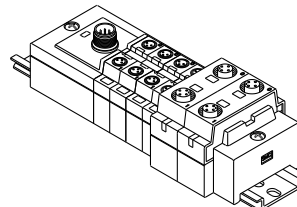

EEX500-IB1-M6 1 set
* EX500-IE1 4 sets
* EX500-IE3 2 sets

Note) 8-point integrated type input block (EX500-IE5/6) is equivalent to 4 stations of 2-point input block (EX500-IE1/2).



Series EX500

Specifications (Input Unit)

Model		EX500-IB1
Input	Number of inputs	16 inputs
	Connection block	EX500-IE□ (Mixed combination is possible.)
	Connection block stations	2-input, input block: Max. 8 stations 8-input, input block: Max. 2 stations
Internal current consumption		100 mA or less
Environment	Enclosure	IP65
	Operating temperature range	Operating: 41 to 113°F [5 to 45°C], Stored: -13 to 158°F [-25 to 70°C] (No freezing and condensation)
	Operating humidity range	Operating, Stored: 35 to 85%RH (No condensation)
Standards		CE marking, UL (CSA), RoHS
Weight		100 g (Input Unit + End block)

Specifications (Input Block)

Model		EX500-IE1	EX500-IE2	EX500-IE3	EX500-IE4	EX500-IE5	EX500-IE6	
Input	Connector type	M8 (3 pins)		M12 (4 pins)		M8 (3 pins)		
	Input type	PNP	NPN	PNP	NPN	PNP	NPN	
	Number of inputs	2 inputs				8 inputs		
	Input device supply voltage	24 VDC						
	Input device supply current	Max. 480 mA/Input Unit manifold						
	Rated input current	Approx. 5 mA						
Environment	Enclosure	IP65						
	Operating temperature range	Operating: 41 to 113°F [5 to 45°C], Stored: -13 to 158°F [-25 to 70°C] (No freezing and condensation)						
	Operating humidity range	Operating, Stored: 35 to 85%RH (No condensation)						
Standards		CE marking, UL (CSA), RoHS compliant						
Weight		20 g		40 g		55 g		
Enclosed parts		Seal cap (for M8 connector) 2 pcs.		Seal cap (for M12 connector) 2 pcs.		Seal cap (for M8 connector) 8 pcs.		

Dimensions/Parts Description

Input block (M8) only

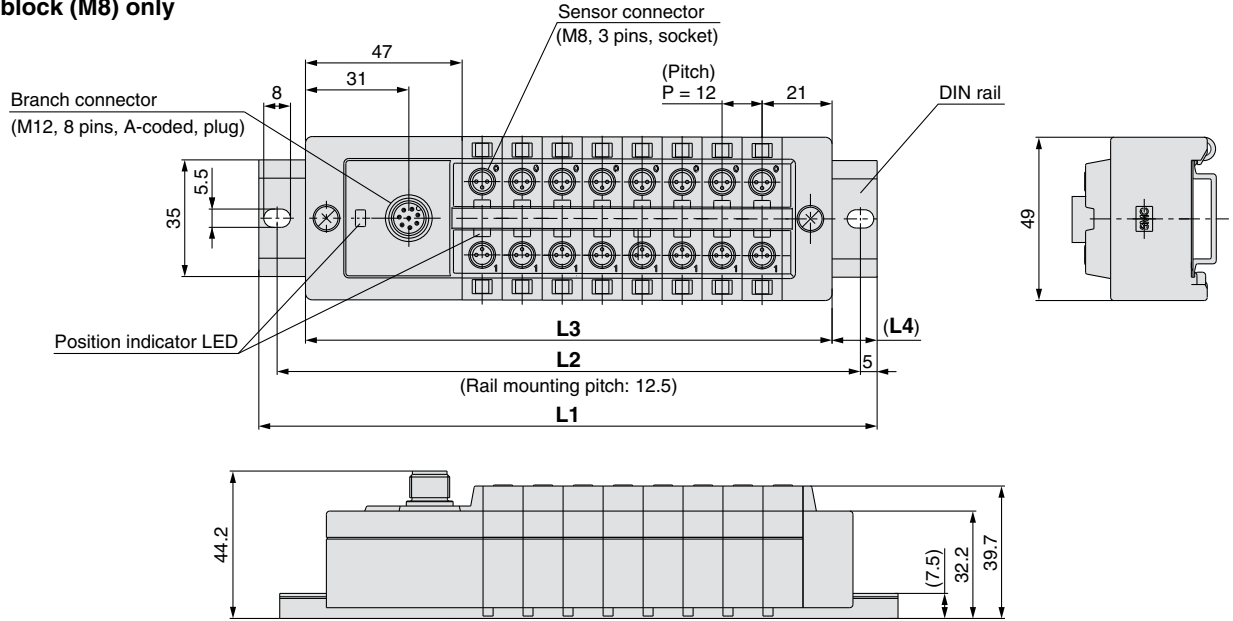

	[mm]							
Stations	1	2	3	4	5	6	7	8
Rail length L1	98	110.5	123	135.5	148	160.5	173	185.5
Mounting pitch L2	87.5	100	112.5	125	137.5	150	162.5	175
Manifold length L3	74	86	98	110	122	134	146	158
L4	12	12	12.5	12.5	13	13	13.5	13.5

Input block (M12) only

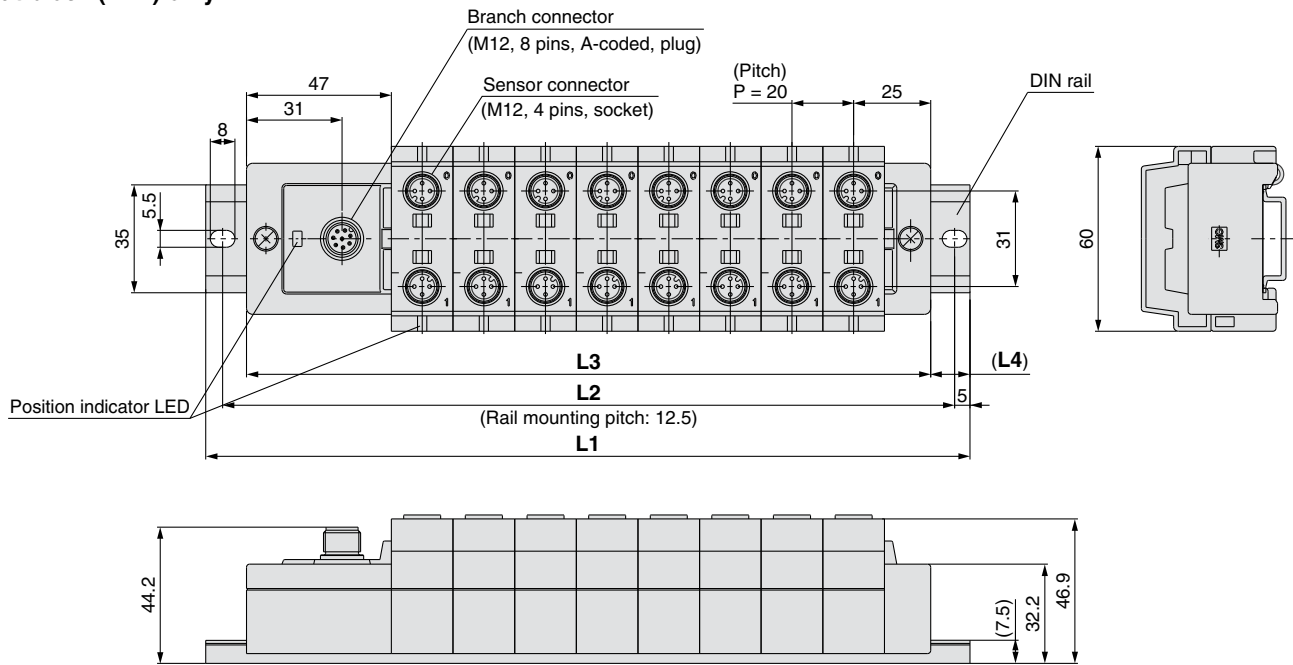

	[mm]							
Stations	1	2	3	4	5	6	7	8
Rail length L1	110.5	123	148	173	185.5	210.5	223	248
Mounting pitch L2	100	112.5	137.5	162.5	175	200	212.5	237.5
Manifold length L3	82	102	122	142	162	182	202	222
L4	12	12	12.5	12.5	13	13	13.5	13.5

Gateway Decentralized System
SY
VQC
S0700
SV

Series EX500

How to Add Input Block Stations

How to add input block stations

1. Loosen the round head combination screws (2 places) that hold the end block.
 2. Separate the blocks at the locations where stations are to be added.
 3. Attach the additional blocks to the DIN rail, and connect the blocks so that they fit together securely.
 4. While holding the blocks together so that there are no gaps between them, secure them to the DIN rail by tightening the round head combination screws.
- Note: Be sure to tighten the round head combination screw with the prescribed tightening torque. (0.44 lbf-ft [0.6 N-m])

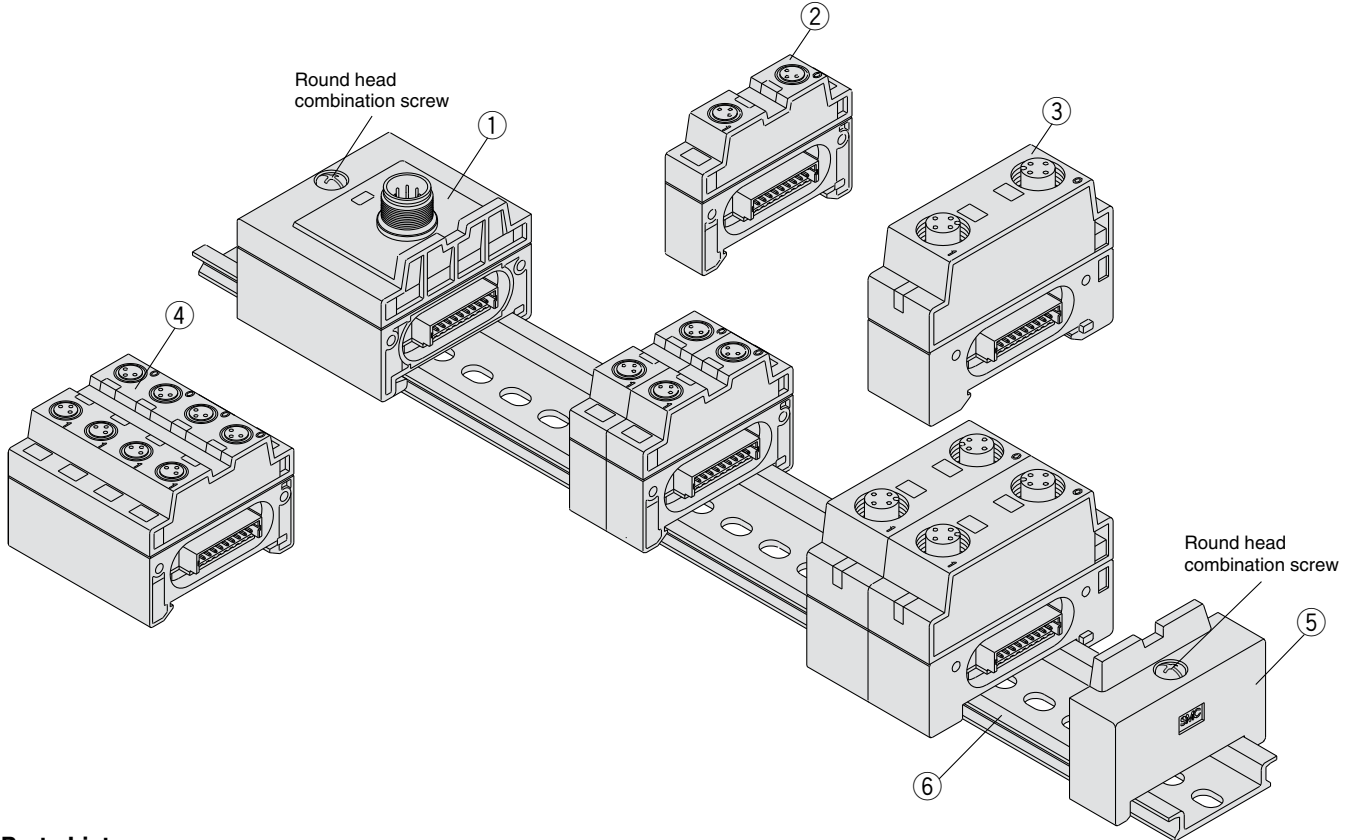

Parts List

No.	Description	Part number	Note
		For standard	
①	Input Unit	EX500-IB1	
②	Input block (M8 connector)	EX500-IE□	PNP Specification...□: 1, NPN Specification...□: 2
③	Input block (M12 connector)	EX500-IE□	PNP Specification...□: 3, NPN Specification...□: 4
④	Input block (M8 connector) 8 points integrated type	EX500-IE□	PNP Specification...□: 5, NPN Specification...□: 6
⑤	End block	EX500-EB1	
⑥	DIN rail	VZ1000-11-1-□	□: Number based on L dimension (Refer to the table below.)

DIN Rail L Dimensions [mm]

Stations	M8 input block (m)									
	0	1	2	3	4	5	6	7	8	
M12 input block (n)	0	1	2	3	4	5	6	7	8	9
	1	2	3	4	5	6	7	8	9	10
	2	3	4	5	6	7	8	9	10	11
	3	4	5	6	7	8	9	10	11	12
	4	5	6	7	8	9	10	11	12	13
	5	6	7	8	9	10	11	12	13	14
	6	7	8	9	10	11	12	13	14	15
	7	8	9	10	11	12	13	14	15	16
	8	9	10	11	12	13	14	15	16	17

Connector type
For E (m = 1 to 8)



L dimensions

No.	L dimension	No.	L dimension
0	98	7	185.5
1	110.5	8	198
2	123	9	210.5
3	135.5	10	223
4	148	11	235.5
5	160.5	12	248
6	173		

Connector type
For M (m + n = 2 to 8)

Connector type
For T (n = 1 to 8)

Accessories

① Communication Cable

For DeviceNet™

EX500 – AC 050 – DN

Cable length (L)

010	1000 [mm]
050	5000 [mm]

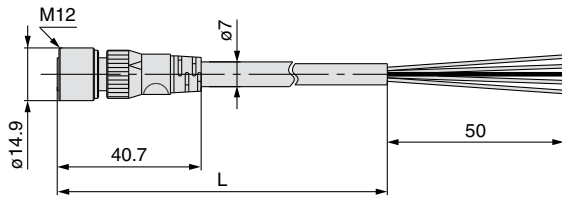

A-coded

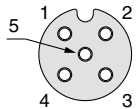

Socket pin arrangement

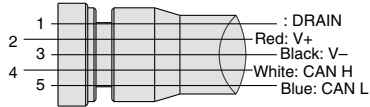

Connections

PCA-1557633

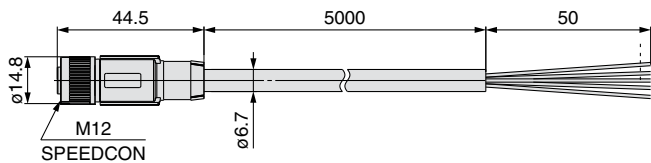

A-coded

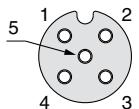

Socket pin arrangement

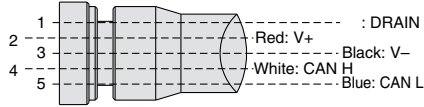

Connections

For PROFIBUS DP

PCA-1557688

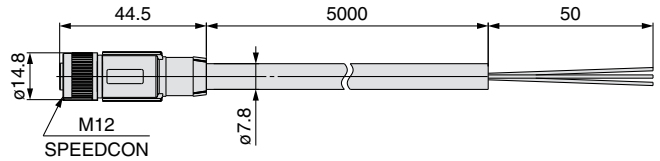

B-coded

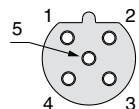

Socket pin arrangement

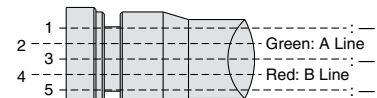

Shield line is connected to the knurl.
Connections

PCA-1557691

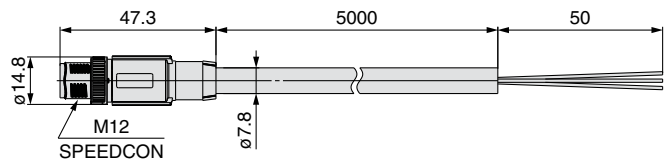

B-coded

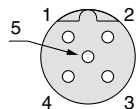

Plug pin arrangement

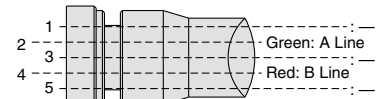

Shield line is connected to the knurl.
Connections

Series EX500

② Power Supply Cable

EX500-AP 050-S

Cable length (L)

010	1000 [mm]
050	5000 [mm]

Connector specification

S	Straight
A	Angle

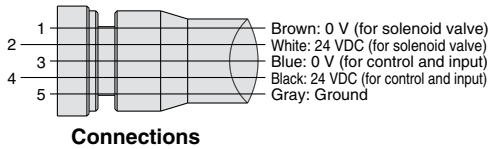
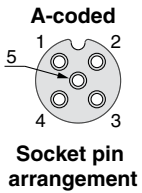
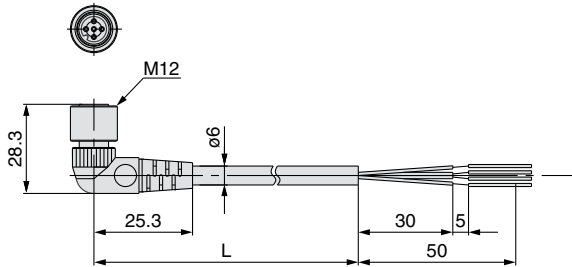
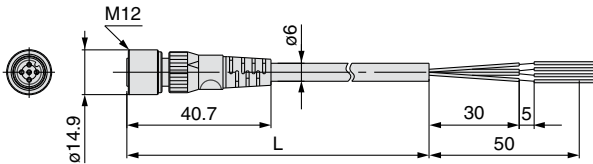

③ Branch Cable

EX500-AC 030-SSPS

Cable length (L)

003	300 [mm]
005	500 [mm]
010	1000 [mm]
030	3000 [mm]
050	5000 [mm]

Connector specification

SSPS	Socket side: Straight Plug side: Straight
SAPA	Socket side: Angle Plug side: Angle

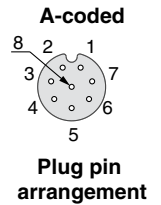
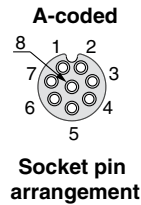
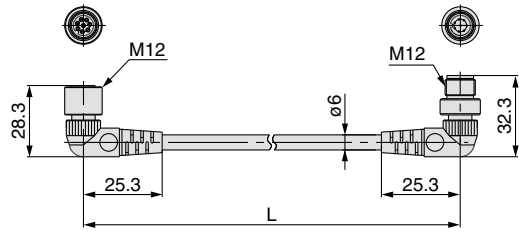
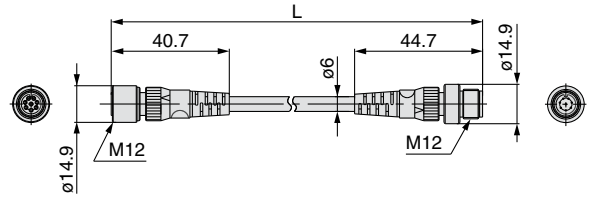

④ **Terminal Plug**

Use this where an input unit manifold is not being used. (If a terminal plug is not used, the GW unit's COM LED will not light up.)

EX500 – AC000 – S

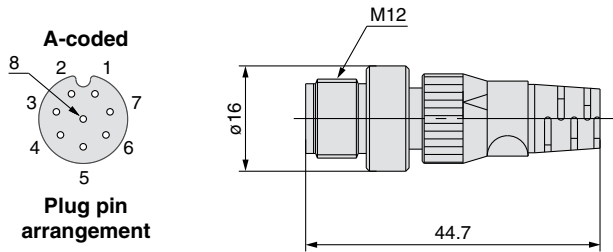

⑥ **Seal Cap (10 pcs.)**

Use with new connector. By using these waterproof caps, the new connector maintains IP65/67 enclosure.

EX9-AWES For M8 connector socket **EX9-AWTS** For M12 connector socket



⑤ **Seal Cap (1 pc.)**

Use with new connector (plug). By using these waterproof caps, the connector maintains IP65/67 enclosure.

EX500 – AWTP

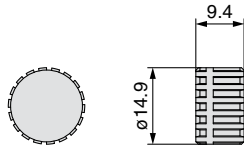

● Refer to page 14 for details about output block and power block.

Gateway Decentralized System

5 Port Solenoid Valve

Series SV1000/2000/3000/4000



For detailed specifications, Common Precautions and Specific Product Precautions, refer to the **WEB catalog** or the SV series catalog (CAT. NAS11-81).

How to Order Manifold

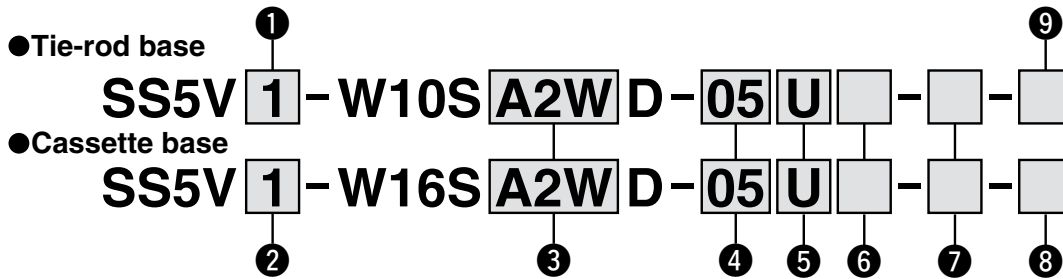

1 Series

1	SV1000
2	SV2000
3	SV3000
4	SV4000

2 Series

1	SV1000
2	SV2000

3 SI Unit (Number of outputs, Output polarity, Max. number of valve stations)

0	Without SI Unit
A2W	16 outputs, Positive common, 1 to 8 stations (16 stations) ^{Note)}

Note) (): Maximum number of stations for mixed

4 Valve stations

Stations	Note
02	2 stations
⋮	⋮
08	8 stations
02	2 stations
⋮	⋮
16	16 stations

Double wiring ^{Note 1)}

Mixed wiring, Specified layout ^{Note 2)}
(Available up to 16 solenoids)

Note 1) Double wiring: single, double, 3-position and 4-position valves can be used on all manifold stations.

Use of a single solenoid will result in an unused control signal. If this is not desired, order with a specified layout.

Note 2) Specified layout: Indicate the wiring specifications on the manifold specification sheet. (Note that double, 3-position and 4-position valves cannot be used where single wiring has been specified.)

5 P, E port entry

U	U side (2 to 10 stations)
D	D side (2 to 10 stations)
B	Both sides (2 to 16 stations)

6 SUP/EXH block assembly

Nil	Internal pilot
S	Internal pilot, Built-in silencer ^{Note)}
R	External pilot
RS	External pilot, Built-in silencer ^{Note)}

Note) When the built-in silencer type is used, keep the exhaust port from coming in direct contact with water or other liquids.

8 DIN rail length specified

Nil	With DIN bracket, DIN rail with standard length
3 ^{Note)}	With DIN bracket, DIN rail for 3 stations
⋮	⋮
16 ^{Note)}	With DIN bracket, DIN rail for 16 stations

Note) Specify a longer rail than the length of valve stations.

* If the DIN rail must be mounted without an SI Unit, select "D 0" and order the DIN rail separately. Refer to L3 of the dimensions for the DIN rail length. For the DIN rail part number, refer to the **WEB catalog** or the SY series catalog (CAT. NAS11-103).

9 Mounting

Nil	Direct mounting
D	With DIN bracket, DIN rail with standard length
D0	With DIN bracket, without DIN rail
D3 ^{Note)}	With DIN bracket, DIN rail for 3 stations
⋮	⋮
D16 ^{Note)}	With DIN bracket, DIN rail for 16 stations

Note) Specify a longer rail than the length of valve stations.

* If the DIN rail must be mounted without an SI Unit, select "D 0" and order the DIN rail separately. Refer to L3 of the dimensions for the DIN rail length. For the DIN rail part number, refer to the **WEB catalog** or the SV series catalog (CAT. NAS11-81).

7 A, B port size

Metric size			
Symbol	A, B port	P, E port	Applicable series
C3	ø3.2 One-touch fitting	ø8 One-touch fitting	SV1000
C4	ø4 One-touch fitting		
C6	ø6 One-touch fitting		
C4	ø4 One-touch fitting	ø10 One-touch fitting	SV2000
C6	ø6 One-touch fitting		
C8	ø8 One-touch fitting		
C6	ø6 One-touch fitting	ø12 One-touch fitting	SV3000
C8	ø8 One-touch fitting		
C10	ø10 One-touch fitting		
C8	ø8 One-touch fitting	ø12 One-touch fitting	SV4000
C10	ø10 One-touch fitting		
C12	ø12 One-touch fitting		
02	Rc1/4	Rc3/8	
03	Rc3/8		
02F	G1/4	G3/8	
03F	G3/8		
M ^{Note)}	A, B port mixed		

Inch size

Symbol	A, B port	P, E port	Applicable series
N1	ø1/8" One-touch fitting	ø5/16" One-touch fitting	SV1000
N3	ø5/32" One-touch fitting		
N7	ø1/4" One-touch fitting		
N3	ø5/32" One-touch fitting	ø3/8" One-touch fitting	SV2000
N7	ø1/4" One-touch fitting		
N9	ø5/16" One-touch fitting		
N7	ø1/4" One-touch fitting	ø3/8" One-touch fitting	SV3000
N9	ø5/16" One-touch fitting		
N11	ø3/8" One-touch fitting		
N9	ø5/16" One-touch fitting	ø3/8" One-touch fitting	SV4000
N11	ø3/8" One-touch fitting		
02N	NPT1/4		
03N	NPT3/8		
02T	NPTF1/4		
03T	NPTF3/8		
M ^{Note)}	A, B port mixed		

Note) Indicate the sizes on the manifold specification sheet.

* The X and PE port size of external pilot type [R, RS] are ø 4 (mm) or ø 5 / 3 2 " (inch) for the SV1000/2000 series, and ø 6 (mm) or ø 1 / 4 " (inch) for the SV3000/4000 series.



Series SV1000/2000/3000/4000

How to Order Valves

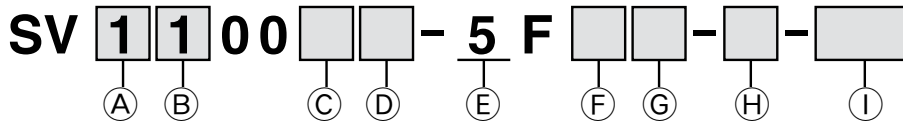

(A) Series

1	SV1000
2	SV2000
3	SV3000
4	SV4000

(B) Type of actuation

1	2-position single
2	2-position double
3	3-position closed center
4	3-position exhaust center
5	3-position pressure center
A <small>Note)</small>	4-position dual 3-port valve (N.C./N.C.)
B <small>Note)</small>	4-position dual 3-port valve (N.O./N.O.)
C <small>Note)</small>	4-position dual 3-port valve (N.C./N.O.)

Note) Select the SV1000 or SV2000 series for the 4-position dual 3-port valve.

* Select the internal pilot type for the 4-position dual 3-port valve.

(C) Pilot type

Nil	Internal pilot
R	External pilot

(D) Back pressure check valve

Nil	None
K	Built-in

* Built-in back pressure check valve type is applicable to the SV1000 series only.

* The product with a back pressure check valve is not available for 3-position valves.

* Refer to the **WEB catalog** for built-in back pressure check valve type.

(E) Rated voltage

5	24 VDC
---	--------

(F) Light/surge voltage suppressor

U	With light/surge voltage suppressor
R	Without light, with surge voltage suppressor

(G) Manual override

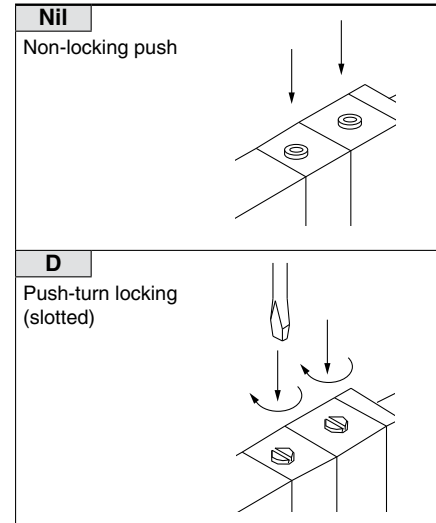

(H) Manifold block

If stations are to be added, order the product with manifold block.

(For details, refer to the **WEB catalog**.)

(I) Made to Order

Nil	—
X90	Main valve fluororubber specification (For details, refer to the WEB catalog .)

How to Order Manifold Assembly

Example

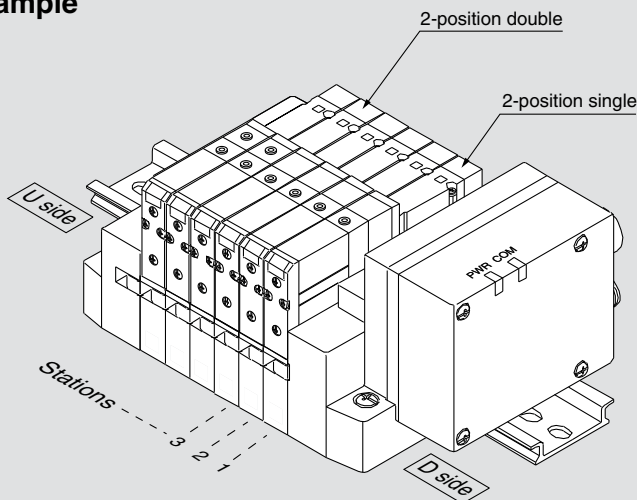

SS5V1-W16SA2WD-06B-C6.....1 set (Manifold base part number)
 * **SV1100-5FU.....4 sets (2-position single part number)**
 * **SV1200-5FU.....2 sets (2-position double part number)**

The asterisk denotes the symbol for assembly. Prefix it to the part numbers of the valve etc.

- The valve arrangement is numbered as the 1st station from the D side.
- Under the manifold base part number, state the valves to be mounted in order from the 1st station as shown in the figure above. If the arrangement becomes complicated, specify on the manifold specification sheet.

Dimensions

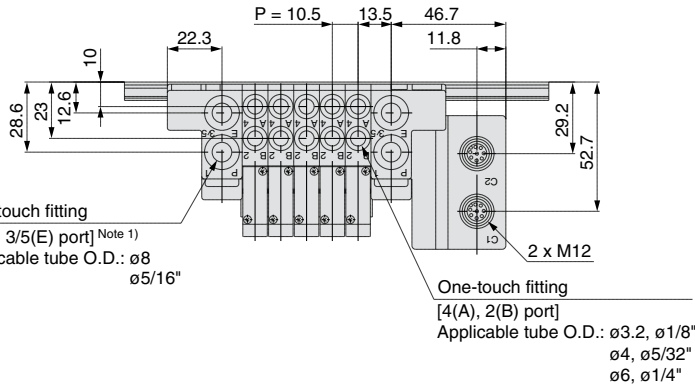

With External Pilot Specification

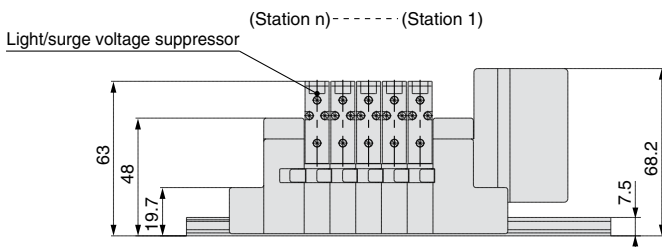
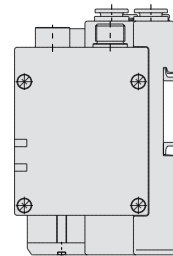
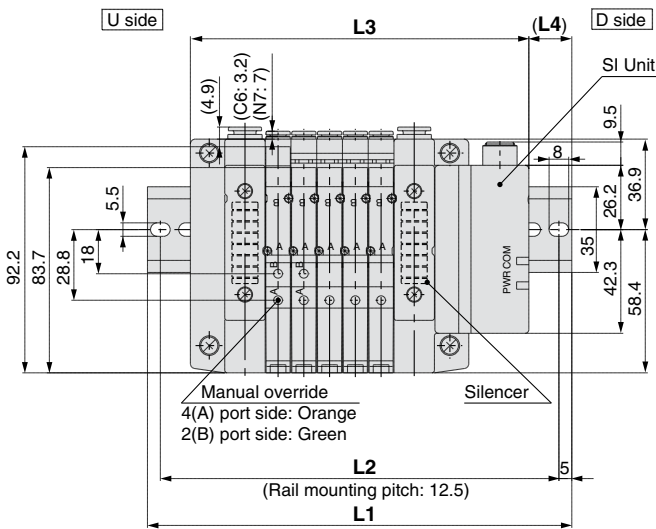
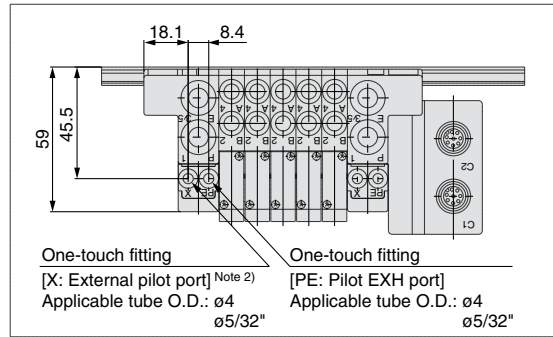

Note 1) When P, E port outlets are indicated on the U side or D side, the P, E ports on the opposite side are plugged.
Note 2) External pilot port positions and silencer discharge port positions are the same as P, E port outlet positions.

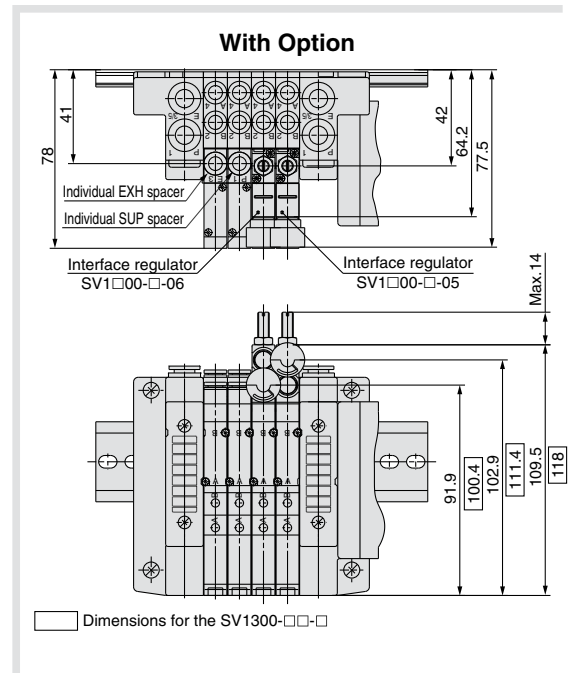

L: Dimensions

L \ n	n: Stations															
	2	3	4	5	6	7	8	9	10	11	12	13	14	15	16	
L1	135.5	148	160.5	173	173	185.5	198	210.5	223	235.5	235.5	248	260.5	273	285.5	
L2	125	137.5	150	162.5	162.5	175	187.5	200	212.5	225	225	237.5	250	262.5	275	
L3	106.5	117	127.5	138	148.5	159	169.5	180	190.5	201	211.5	222	232.5	243	253.5	
L4	14.5	15.5	16.5	17.5	12.5	13.5	14.5	15.5	16.5	17.5	12	13	14	15	16	

Series SV2000

Dimensions

Cassette Base Series SV2000

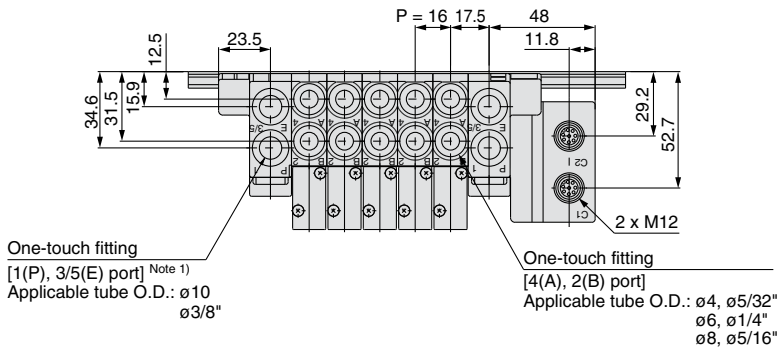

With External Pilot Specification

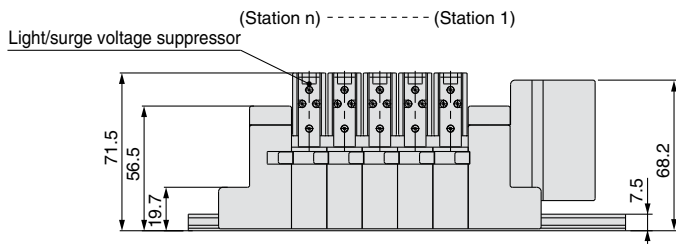
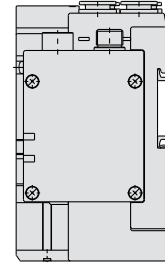
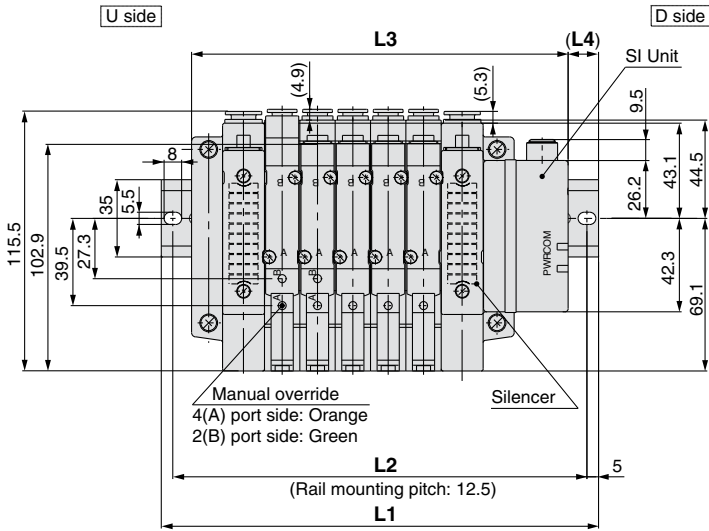
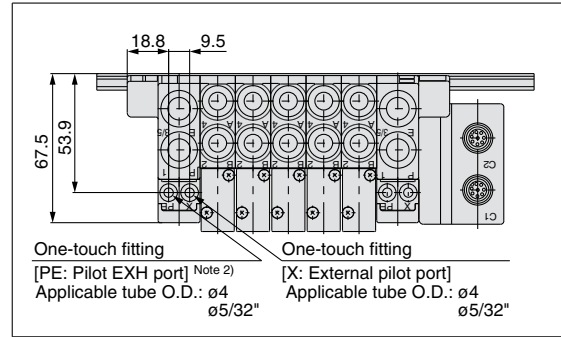

With Option

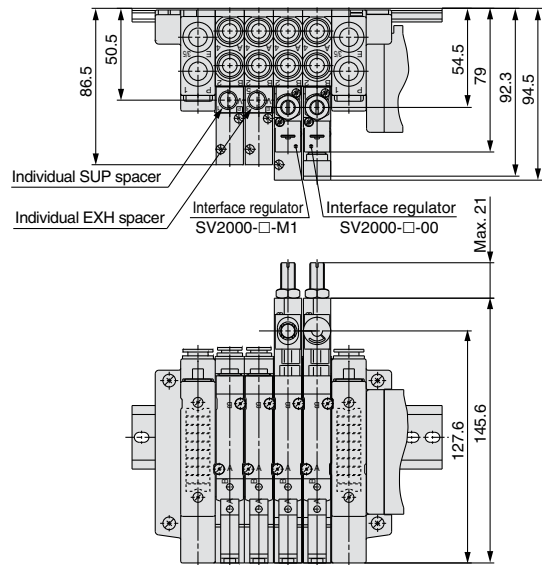

Note 1) When P, E port outlets are indicated on the U side or D side, the P, E ports on the opposite side are plugged.
Note 2) External pilot port positions and silencer discharge port positions are the same as P, E port outlet positions.

L: Dimensions

n: Stations

L \ n	2	3	4	5	6	7	8	9	10	11	12	13	14	15	16
L1	148	173	185.5	198	210.5	235.5	248	260.5	285.5	298	310.5	323	348	360.5	373
L2	137.5	162.5	175	187.5	200	225	237.5	250	275	287.5	300	312.5	337.5	350	362.5
L3	122.5	138.5	154.5	170.5	186.5	202.5	218.5	234.5	250.5	266.5	282.5	298.5	314.5	330.5	346.5
L4	13	17.5	15.5	14	12	16.5	15	13	17.5	16	14	12.5	17	15	13.5

Dimensions

Tie-rod Base Series SV1000

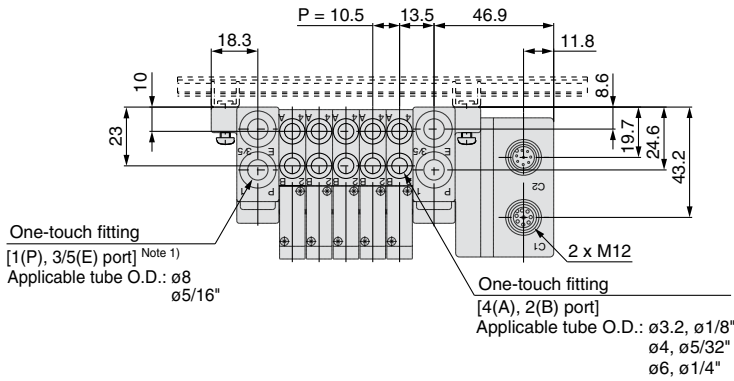

With External Pilot Specification

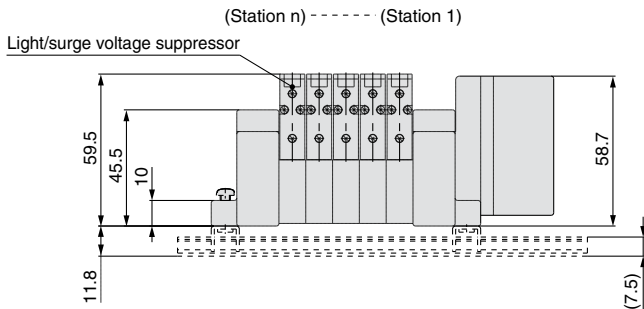
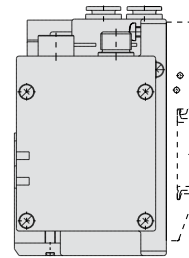
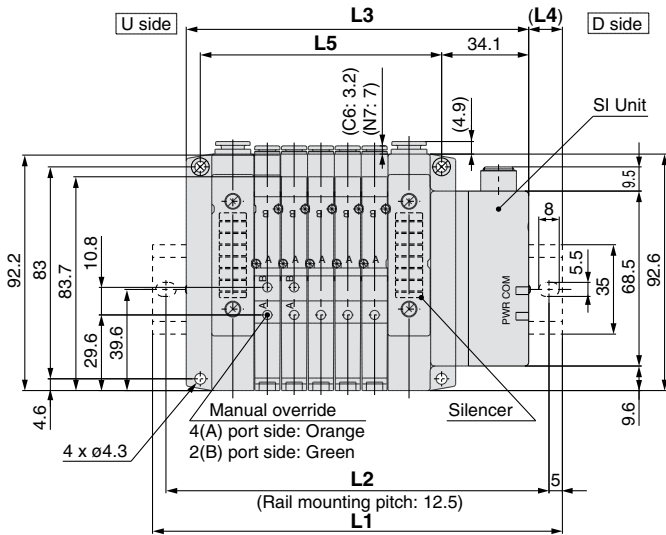
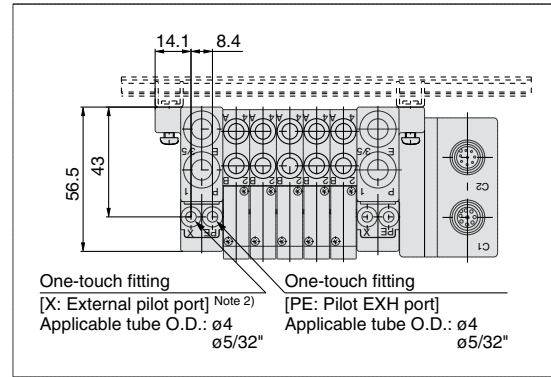

Note 1) When P, E port outlets are indicated on the U side or D side, the P, E ports on the opposite side are plugged.
 Note 2) External pilot port positions and silencer discharge port positions are the same as P, E port outlet positions.

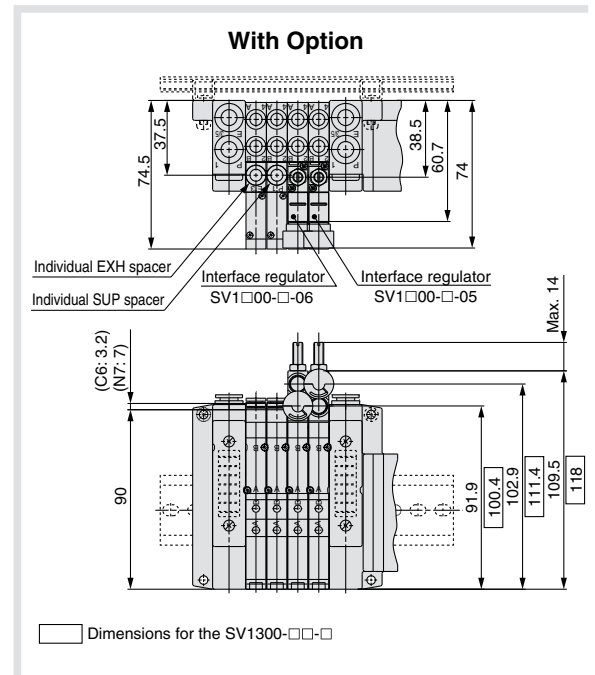

L: Dimensions

		n: Stations															
L	n	2	3	4	5	6	7	8	9	10	11	12	13	14	15	16	
L1		135.5	148	148	160.5	173	185.5	198	210.5	210.5	223	235.5	248	260.5	273	273	
L2		125	137.5	137.5	150	162.5	175	187.5	200	200	212.5	225	237.5	250	262.5	262.5	
L3		102.6	113.1	123.6	134.1	144.6	155.1	165.6	176.1	186.6	197.1	207.6	218.1	228.6	239.1	249.6	
L4		16.5	17.5	12	13	14	15	16	17	12	13	14	15	16	17	11.5	
L5		63	73.5	84	94.5	105	115.5	126	136.5	147	157.5	168	178.5	189	199.5	210	

□ Dimensions for the SV1300-□-□-□

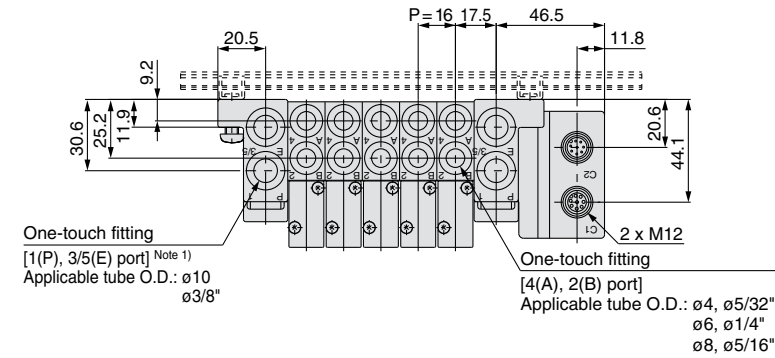

With External Pilot Specification

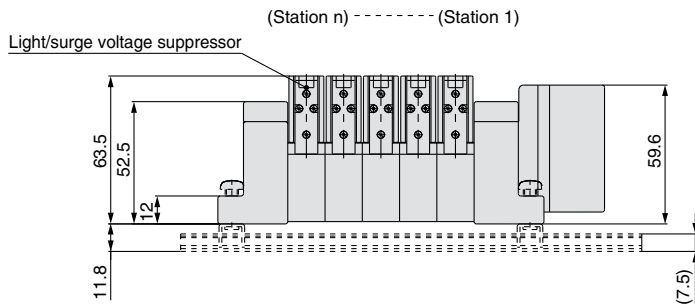
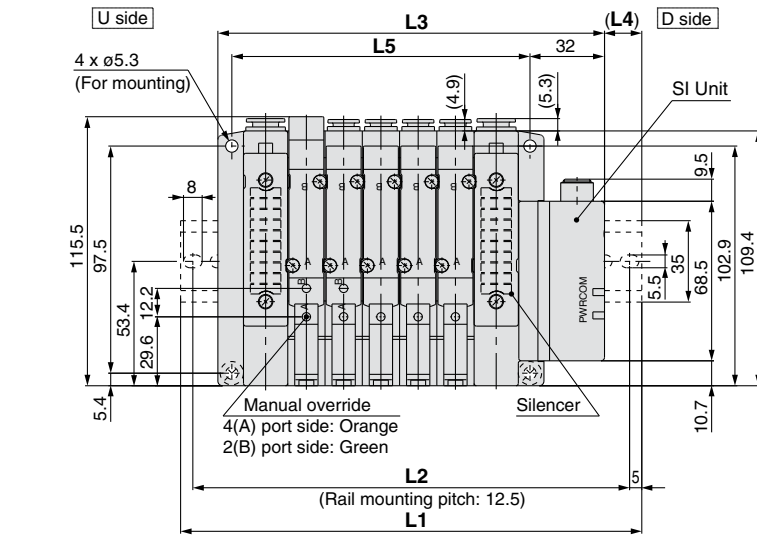
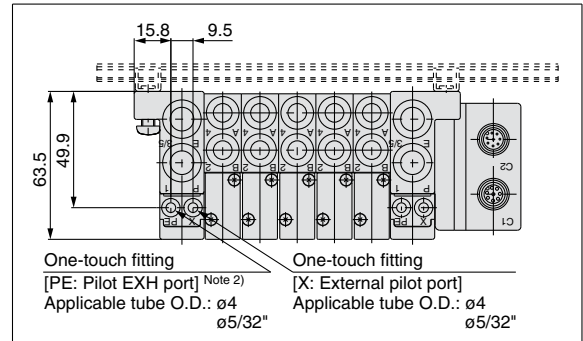

Note 1) When P, E port outlets are indicated on the U side or D side, the P, E ports on the opposite side are plugged.

Note 2) External pilot port positions and silencer discharge port positions are the same as P, E port outlet positions.

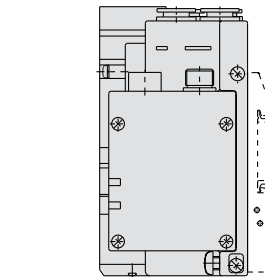

With Option

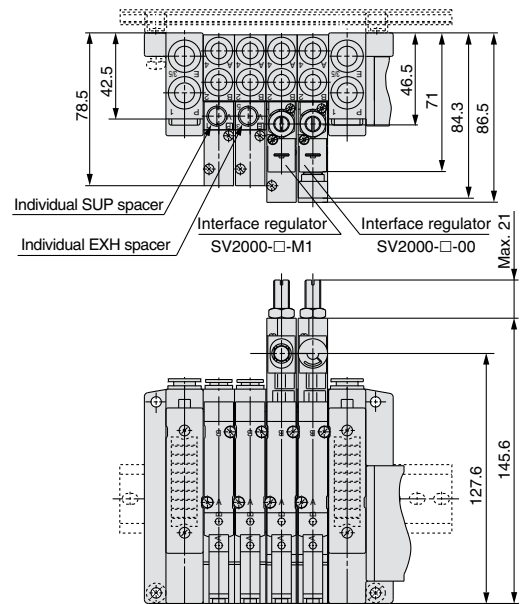

L: Dimensions

L	n	2	3	4	5	6	7	8	9	10	11	12	13	14	15	16
L1	n	148	160.5	185.5	198	210.5	223	248	260.5	273	285.5	310.5	323	335.5	360.5	373
L2	n	137.5	150	175	187.5	200	212.5	237.5	250	262.5	275	300	312.5	325	350	362.5
L3	n	118	134	150	166	182	198	214	230	246	262	278	294	310	326	342
L4	n	15	13.5	18	16	14.5	12.5	17	15.5	13.5	12	16.5	14.5	13	17.5	15.5
L5	n	80	96	112	128	144	160	176	192	208	224	240	256	272	288	304

Dimensions

Tie-rod Base Series SV3000

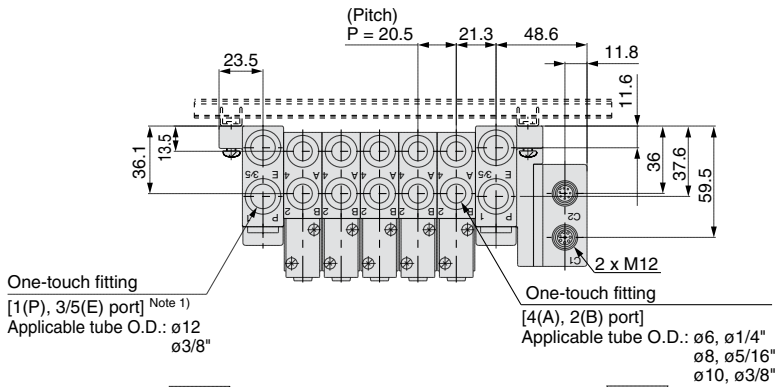

U side D side

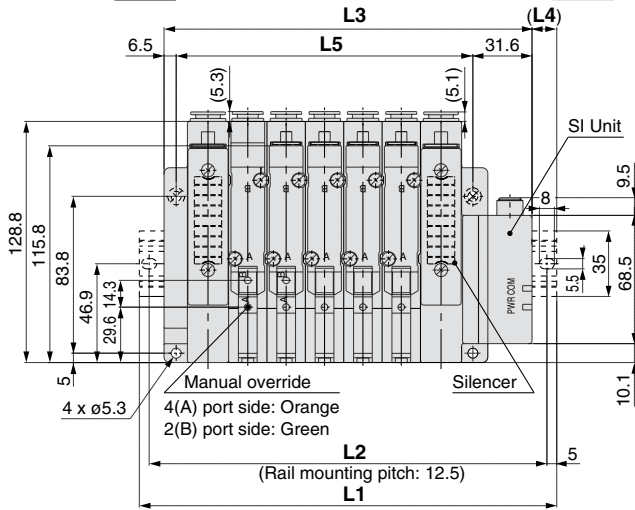

With External Pilot Specification

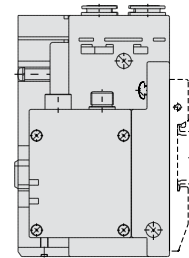
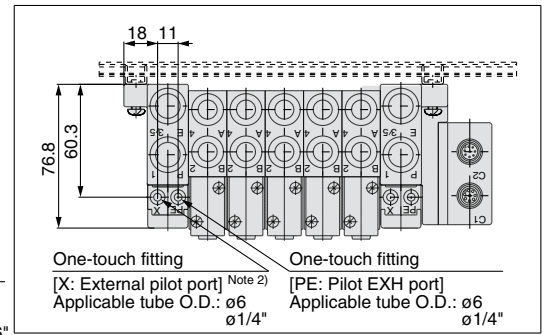

(Station n)----- (Station 1)

Light/surge voltage suppressor

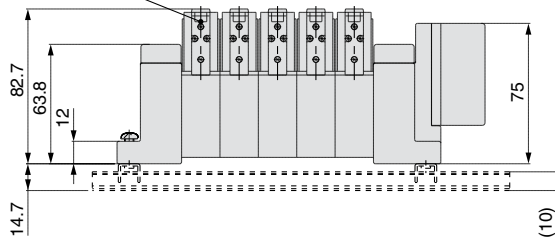

With Option

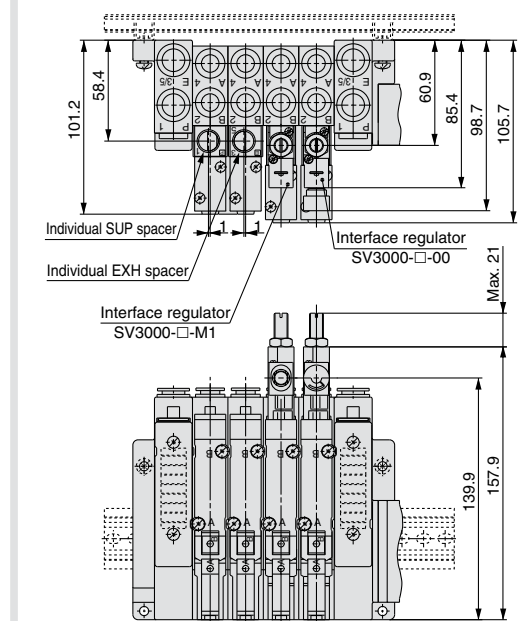

- Note 1) When P, E port outlets are indicated on the U side or D side, the P, E ports on the opposite side are plugged.
- Note 2) External pilot port positions and silencer discharge port positions are the same as P, E port outlet positions.

L: Dimensions

L	n	n: Stations															
		2	3	4	5	6	7	8	9	10	11	12	13	14	15	16	
L1		160.5	185.5	210.5	223	248	273	285.5	310.5	323	348	373	385.5	410.5	435.5	448	
L2		150	175	200	212.5	237.5	262.5	275	300	312.5	337.5	362.5	375	400	425	437.5	
L3		135.1	155.6	176.1	196.6	217.1	237.6	258.1	278.6	299.1	319.6	340.1	360.6	381.1	401.6	422.1	
L4		12.5	15	17	13	15.5	17.5	13.5	16	12	14	16.5	12.5	14.5	17	13	
L5		97	117.5	138	158.5	179	199.5	220	240.5	261	281.5	302	322.5	343	363.5	384	

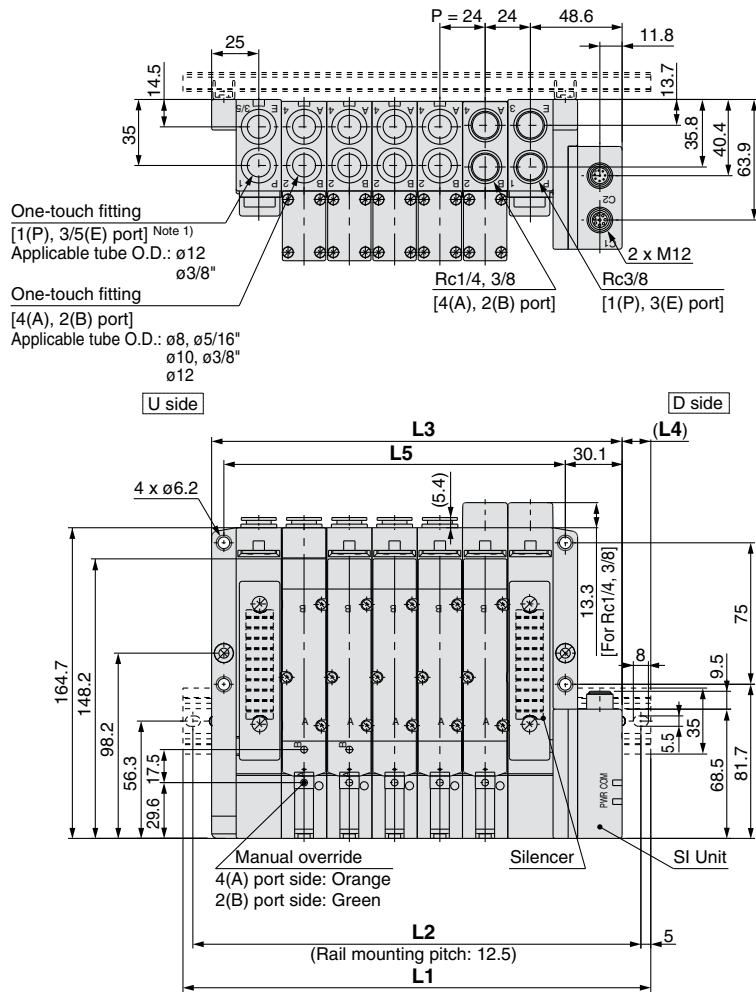

With External Pilot Specification

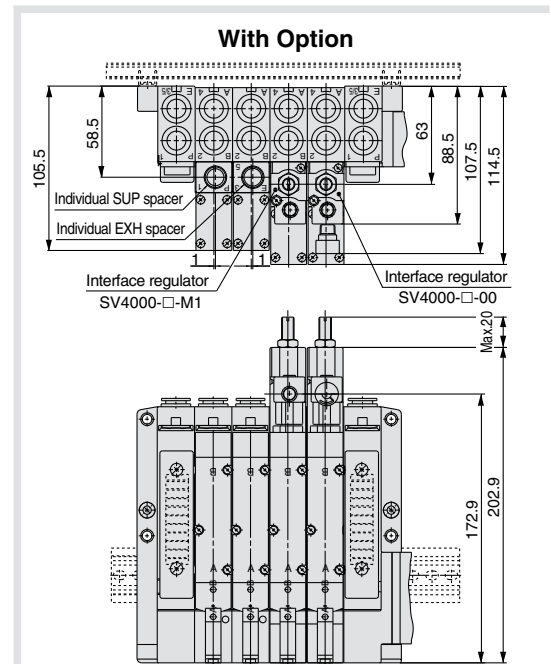
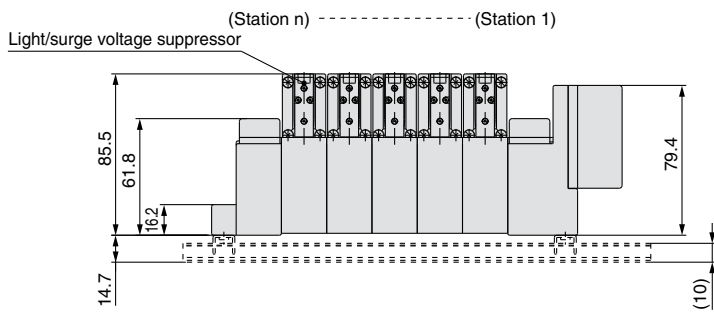
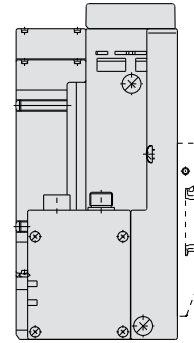
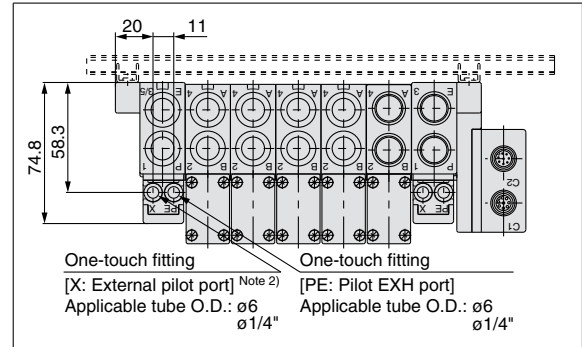

Note 1) When P, E port outlets are indicated on the U side or D side, the P, E ports on the opposite side are plugged.

Note 2) External pilot port positions and silencer discharge port positions are the same as P, E port outlet positions.

L: Dimensions

L	n: Stations															
	2	3	4	5	6	7	8	9	10	11	12	13	14	15	16	
L1	173	198	223	248	273	298	323	348	373	385.5	410.5	435.5	460.5	485.5	510.5	
L2	162.5	187.5	212.5	237.5	262.5	287.5	312.5	337.5	362.5	375	400	425	450	475	500	
L3	145.6	169.6	193.6	217.6	241.6	265.6	289.6	313.6	337.6	361.6	385.6	409.6	433.6	457.6	481.6	
L4	13.5	14	14.5	15	15.5	16	16.5	17	17.5	12	12.5	13	13.5	14	14.5	
L5	109	133	157	181	205	229	253	277	301	325	349	373	397	421	445	



Series EX500

Specific Product Precautions 1

Be sure to read this before handling. Refer to the back cover for Safety Instructions. For 3/4/5 Port Solenoid Valve Precautions, refer to “Handling Precautions for SMC Products” and the Operation Manual on the SMC website, <http://www.smcworld.com>

Design / Selection

Warning

- 1. Do not use beyond the specification range.**

Using beyond the specification range can cause a fire, malfunction, or damage to the system.
Check the specifications before operation.
- 2. When using for an interlock circuit:**
 - Provide a multiple interlock system which is operated by another system (such as mechanical protection function).
 - Perform an inspection to confirm that it is working properly.

Otherwise, this may cause possible injuries due to malfunction.

Caution

- 1. When applicable to UL, use a Class 2 power supply unit conforming to UL1310 for direct current power supply.**
- 2. Use within the specified voltage range.**

Using beyond the specified voltage range is likely to cause the product to be damaged or to malfunction.
- 3. Do not install in places where it can be used as a foothold.**

Applying any excessive load such as stepping on the product by mistake or placing a foot on it, will cause it to break.
- 4. Keep the surrounding space free for maintenance.**

When designing a system, take into consideration the amount of free space needed for performing maintenance.
- 5. Do not remove the name plate.**

Improper maintenance or incorrect use of Operation Manual can cause equipment failure or malfunction. Also, there is a risk of losing conformity with safety standards.

Mounting

Caution

- 1. When removing from / attaching to the valve manifold,**
 - Do not apply excessive force to the Unit.
The connecting portions are firmly joined with seals.
 - Take care not to get fingers caught.
Injury can result.
- 2. Do not drop, bump, or apply excessive impact.**

Otherwise, this can cause damage, equipment failure or malfunction.
- 3. Observe the tightening torque range.**

Tightening outside of the allowable torque range will likely damage the screw.
IP65/IP67 cannot be guaranteed if the screws are not tightened to the specified torque.

Mounting

Caution

- 4. When lifting a large size valve manifold, take care to avoid causing stress to the valve connection joint.**

The connection joint of the product may be damaged.
Because the product may be heavy, carrying and installation should be performed by more than one operator to avoid strain or injury.
- 5. When placing a manifold, mount it on a flat surface.**

Torsion in the whole manifold can lead to trouble such as air leakage or contact failure.

Wiring

Caution

- 1. Provide the grounding to maintain the safety of the product and to improve the noise immunity.**

Provide a specific grounding as close to the product as possible to minimize the distance to grounding.
- 2. Avoid repeatedly bending or stretching the cable and applying a heavy object or force to it.**

Wiring applying repeated bending and tensile stress to the cable can break the circuit.
- 3. Avoid miswiring.**

If miswired, there is a danger of malfunction or damage to the product.
- 4. Do not wire while energizing the product.**

There is a danger of malfunction or damage to the product or input/output device.
- 5. Avoid wiring the power line and high pressure line in parallel.**

Noise or surge produced by signal line resulting from the power line or high pressure line could cause a malfunction.
Wiring of the product or input/output device and the power line or high pressure line should be separated from each other.
- 6. Check for the wiring insulation.**

Defective insulation (contact with other circuits, improper insulation between terminals, etc.) may cause damage to the product or input/output device due to excessive voltage or current.



Series EX500

Specific Product Precautions 2

Be sure to read this before handling. Refer to the back cover for Safety Instructions. For 3/4/5 Port Solenoid Valve Precautions, refer to "Handling Precautions for SMC Products" and the Operation Manual on the SMC website, <http://www.smcworld.com>

Wiring

Caution

7. When the product is installed in machinery/equipment, provide adequate protection against noise by using noise filters etc.

Noise in signal lines may cause a malfunction.

8. When connecting wires, prevent water, solvent or oil from entering inside from the connector section.

Otherwise, this can cause damage, equipment failure or malfunction.

9. Avoid wiring patterns in which excessive stress is applied to the connector.

This may cause equipment failure or malfunction due to contact failure.

Operating Environment

Warning

1. Do not use in an atmosphere containing an inflammable gas or explosive gas.

Use in such an atmosphere is likely to cause a fire or explosion. This system is not explosion-proof.

Caution

1. Select the proper type of enclosure according to the environment of operation.

IP65/67 is achieved when the following conditions are met.

- 1) Provide appropriate wiring between the products using electrical wiring cables, communication connectors and cables with M12 connectors.
- 2) Suitable mounting of the product and valve manifold.
- 3) Be sure to mount a seal cap on any unused connectors.

If using in an environment that is exposed to water splashes, please take measures such as using a cover.

When the enclosure is IP40, do not use in an operating environment or atmosphere where it may come in contact with corrosive gas, chemical agents, seawater, water, or water vapor.

2. Provide adequate protection when operating in locations such as the following.

Failure to do so may cause a malfunction or equipment failure.

The effect of countermeasures should be checked in individual equipment and machine.

- 1) Where noise is generated by static electricity etc.
- 2) Where there is a strong electric field
- 3) Where there is a danger of exposure to radiation
- 4) When in close proximity to power supply lines

3. Do not use in an environment where oil and chemicals are used.

Operating in environments with coolants, cleaning solvents, various oils or chemicals may cause adverse effects (damage, malfunction) to the product even in a short period of time.

Operating Environment

Caution

4. Do not use in an environment where the product could be exposed to corrosive gas or liquid.

This may damage the product and cause it to malfunction.

5. Do not use in locations with sources of surge generation.

Installation of the product in an area around the equipment

(electromagnetic lifters, high frequency induction furnaces, welding machine, motors, etc.), which generates the large surge voltage could cause to deteriorate an internal circuitry element of the product or result in damage. Implement countermeasures against the surge from the generating source, and avoid touching the lines with each other.

6. When directly driving a load (output device) which generates surge voltage by relay, solenoid valves or lamp, use a load that has an integrated surge absorption element.

When a surge generating load is directly driven, the product may be damaged.

7. The product is CE marked, but not immune to lightning strikes. Take measures against lightning strikes in your system.

8. Keep dust, wire scraps and other foreign matter from entering inside the product.

This may cause equipment failure or malfunction.

9. Mount the product in such locations, where no vibration or shock is affected.

This may cause equipment failure or malfunction.

10. Do not use in places where there are cyclic temperature changes.

In case that the cyclic temperature is beyond normal temperature changes, the internal product is likely to be adversely affected.

11. Do not use in direct sunlight.

This may cause equipment failure or malfunction.

12. Observe the ambient temperature range.

This may cause a malfunction.

13. Do not use in places where there is radiated heat around it.

Such places are likely to cause a malfunction.



Series EX500

Specific Product Precautions 3

Be sure to read this before handling. Refer to the back cover for Safety Instructions. For 3/4/5 Port Solenoid Valve Precautions, refer to "Handling Precautions for SMC Products" and the Operation Manual on the SMC website, <http://www.smcworld.com>

Adjustment / Operation

Warning

1. Do not perform operation or setting with wet hands.

There is a risk of electrical shock.

<Web server function>

2. The valve operation test is a function which forcibly changes the signal status. Please check safety of the ambient environment and the device before using this function.

This may cause injuries or equipment damage.

3. If the communication line and PC are shut down during a valve operation test, the valve output status will be held (It remains in the output status before the communication line and/or PC was shut down). Please check safety of the ambient environment and the device when performing this function.

This may cause injuries or equipment damage.

Caution

1. Use a watchmaker's screwdriver with thin blade for the setting switch.

When setting the switch, do not touch other unrelated parts.

This may cause parts damage or malfunction due to a short circuit.

2. Provide adequate setting for the operating conditions.

Failure to do so could result in malfunction.

Refer to the Operation Manual for the setting switch.

3. For details on programming and address setting, refer to the manual from the PLC manufacturer.

The content of programming related to protocol is designed by the manufacturer of the PLC used.

Maintenance

Warning

1. Do not disassemble, modify (including circuit board replacement) or repair this product.

Such actions are likely to cause injuries or equipment failure.

2. When an inspection is performed,

- Turn off the power supply.
- Stop the air supply, exhaust the residual pressure in piping and verify that the air is released before performing maintenance work.

Unexpected malfunction of system components and injury can result.

Caution

1. When removing from / attaching to the valve manifold,

- Do not apply excessive force to the Unit.

The connecting portions are firmly joined with seals.

- Take care not to get fingers caught.

Injury can result.

2. Perform periodic inspection.

Unexpected malfunction in the system composition devices is likely to occur due to malfunction of machinery or equipment.

3. After maintenance, make sure to perform an appropriate functionality inspection.

In cases of abnormality such as faulty operation, stop operation. Unexpected malfunction in the system composition devices is likely to occur.

4. Do not use benzine and thinner for cleaning the product.

Damage to the surface or erasure of the display can result. Wipe off any stains with a soft cloth.

If the stain is persistent, wipe off with a cloth soaked in a dilute solution of neutral detergent and wring out tightly, and then finish with a dry cloth.

Other

Caution

1. Refer to the catalog of each series for Common Precautions and Specific Product Precautions on valve manifolds.

■ Trademark

DeviceNet™ is a trademark of ODVA.

EtherNet/IP™ is a trademark of ODVA.

Safety Instructions

These safety instructions are intended to prevent hazardous situations and/or equipment damage. These instructions indicate the level of potential hazard with the labels of “Caution,” “Warning” or “Danger.” They are all important notes for safety and must be followed in addition to International Standards (ISO/IEC)*1), and other safety regulations.

 **Caution:** Caution indicates a hazard with a low level of risk which, if not avoided, could result in minor or moderate injury.

 **Warning:** Warning indicates a hazard with a medium level of risk which, if not avoided, could result in death or serious injury.

 **Danger :** Danger indicates a hazard with a high level of risk which, if not avoided, will result in death or serious injury.

Warning

1. The compatibility of the product is the responsibility of the person who designs the equipment or decides its specifications.

Since the product specified here is used under various operating conditions, its compatibility with specific equipment must be decided by the person who designs the equipment or decides its specifications based on necessary analysis and test results. The expected performance and safety assurance of the equipment will be the responsibility of the person who has determined its compatibility with the product. This person should also continuously review all specifications of the product referring to its latest catalog information, with a view to giving due consideration to any possibility of equipment failure when configuring the equipment.

2. Only personnel with appropriate training should operate machinery and equipment.

The product specified here may become unsafe if handled incorrectly. The assembly, operation and maintenance of machines or equipment including our products must be performed by an operator who is appropriately trained and experienced.

3. Do not service or attempt to remove product and machinery/equipment until safety is confirmed.

1. The inspection and maintenance of machinery/equipment should only be performed after measures to prevent falling or runaway of the driven objects have been confirmed.
2. When the product is to be removed, confirm that the safety measures as mentioned above are implemented and the power from any appropriate source is cut, and read and understand the specific product precautions of all relevant products carefully.
3. Before machinery/equipment is restarted, take measures to prevent unexpected operation and malfunction.

4. Contact SMC beforehand and take special consideration of safety measures if the product is to be used in any of the following conditions.

1. Conditions and environments outside of the given specifications, or use outdoors or in a place exposed to direct sunlight.
2. Installation on equipment in conjunction with atomic energy, railways, air navigation, space, shipping, vehicles, military, medical treatment, combustion and recreation, or equipment in contact with food and beverages, emergency stop circuits, clutch and brake circuits in press applications, safety equipment or other applications unsuitable for the standard specifications described in the product catalog.
3. An application which could have negative effects on people, property, or animals requiring special safety analysis.
4. Use in an interlock circuit, which requires the provision of double interlock for possible failure by using a mechanical protective function, and periodical checks to confirm proper operation.

- *1) ISO 4414: Pneumatic fluid power – General rules relating to systems.
ISO 4413: Hydraulic fluid power – General rules relating to systems.
IEC 60204-1: Safety of machinery – Electrical equipment of machines.
(Part 1: General requirements)
ISO 10218-1: Manipulating industrial robots – Safety.
etc.

Caution

1. The product is provided for use in manufacturing industries.

The product herein described is basically provided for peaceful use in manufacturing industries.
If considering using the product in other industries, consult SMC beforehand and exchange specifications or a contract if necessary.
If anything is unclear, contact your nearest sales branch.

Limited warranty and Disclaimer/ Compliance Requirements

The product used is subject to the following “Limited warranty and Disclaimer” and “Compliance Requirements”.

Read and accept them before using the product.

Limited warranty and Disclaimer

1. The warranty period of the product is 1 year in service or 1.5 years after the product is delivered, whichever is first.*2)
Also, the product may have specified durability, running distance or replacement parts. Please consult your nearest sales branch.
2. For any failure or damage reported within the warranty period which is clearly our responsibility, a replacement product or necessary parts will be provided.
This limited warranty applies only to our product independently, and not to any other damage incurred due to the failure of the product.
3. Prior to using SMC products, please read and understand the warranty terms and disclaimers noted in the specified catalog for the particular products.

*2) Vacuum pads are excluded from this 1 year warranty.

A vacuum pad is a consumable part, so it is warranted for a year after it is delivered.
Also, even within the warranty period, the wear of a product due to the use of the vacuum pad or failure due to the deterioration of rubber material are not covered by the limited warranty.

Compliance Requirements

1. The use of SMC products with production equipment for the manufacture of weapons of mass destruction (WMD) or any other weapon is strictly prohibited.
2. The exports of SMC products or technology from one country to another are governed by the relevant security laws and regulations of the countries involved in the transaction. Prior to the shipment of a SMC product to another country, assure that all local rules governing that export are known and followed.

Caution

SMC products are not intended for use as instruments for legal metrology.

Measurement instruments that SMC manufactures or sells have not been qualified by type approval tests relevant to the metrology (measurement) laws of each country. Therefore, SMC products cannot be used for business or certification ordained by the metrology (measurement) laws of each country.

Safety Instructions

Be sure to read the “Handling Precautions for SMC Products” (M-E03-3) and “Operation Manual” before use.

SMC Corporation of America
10100 SMC Blvd., Noblesville, IN 46060
www.smcusa.com

SMC Pneumatics (Canada) Ltd.
www.smcpcanada.com

(800) SMC.SMC1 (762-7621)
e-mail: sales@smcusa.com
International inquiries: www.smcworld.com



Series 10-SV1000/2000/3000/4000 5 Port Solenoid Valve

Serial wiring

Decentralized serial wiring

P.182

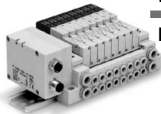

IP67 compliant

Applicable series	Cassette base manifold
	10-SV1000/10-SV2000
Applicable series	Tie-rod base manifold
	10-SV1000/10-SV2000/10-SV3000/10-SV4000
<ul style="list-style-type: none"> · Number of outputs: 16 · EX500 gateway communication specifications · DeviceNet™, PROFIBUS-DP, EtherNet/IP™ 	



Serial wiring with input/output unit

P.192

IP67 compliant

Applicable series	Tie-rod base manifold
	10-SV1000/10-SV2000/10-SV3000
<ul style="list-style-type: none"> · Number of inputs/outputs: 32 each 	



IP67 compliant

Applicable series	Tie-rod base manifold
	10-SV1000/10-SV2000/10-SV3000
<ul style="list-style-type: none"> · Digital inputs/outputs: Max. 144/144 · Analog input: Max. 18 channels · Number of valve outputs: 32 	



Dedicated output serial wiring

P.208

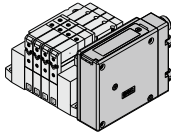

IP67 compliant
(Some products are IP40)

Applicable series	Cassette base manifold
	10-SV1000/10-SV2000
Applicable series	Tie-rod base manifold
	10-SV1000/10-SV2000/10-SV3000/10-SV4000
<ul style="list-style-type: none"> · Number of outputs: 16 	
Applicable series	Tie-rod base manifold
	10-SV1000/10-SV2000/10-SV3000
<ul style="list-style-type: none"> · Number of outputs: 32/16 	

Parallel wiring

For circular connector

P.230

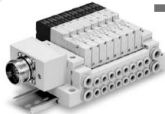

IP67 compliant

Applicable series	Cassette base manifold
	10-SV1000/10-SV2000
Applicable series	Tie-rod base manifold
	10-SV1000/10-SV2000/10-SV3000/10-SV4000
<ul style="list-style-type: none"> · Number of connectors: 26 pins 	



D-sub connector

P.240

Applicable series	Cassette base manifold
	10-SV1000/10-SV2000
Applicable series	Tie-rod base manifold
	10-SV1000/10-SV2000/10-SV3000/10-SV4000
<ul style="list-style-type: none"> · Number of connectors: 25 pins · MIL-C-24308 · Conforming to JIS-X-5101 	



Flat ribbon cable connector

P.250

Applicable series	Cassette base manifold
	10-SV1000/10-SV2000
Applicable series	Tie-rod base manifold
	10-SV1000/10-SV2000/10-SV3000/10-SV4000
<ul style="list-style-type: none"> · Number of connectors: 26, 20, 10 pins · With strain relief · Conforming to MIL-C-83503 	



Valve manifold specifications

P.260

Manifold option

Single unit/Sub-plate [IP67 compliant]

P.265

IP67 compliant	Applicable series	10-SV1000/10-SV2000/10-SV3000/10-SV4000
		<ul style="list-style-type: none"> · With waterproof M12 connector

Valve Manifold Common Specifications

Cassette base manifold

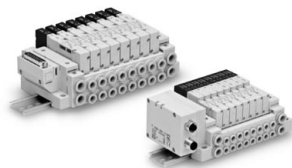

Manifold Specifications

Applicable series		10-SV1000	10-SV2000
Manifold type		Stacking type cassette base manifold	
1 (P: SUP), 3/5 (E: EXH) type		Common SUP, EXH	
Valve stations (maximum)		18 stations	20 stations
Max. number of solenoids		18 points	26 points
Port size	1(P), 3/5(E) port	C8, N9	C10, N11
	4(A), 2(B) port	C3, C4, C6 N1, N3, N7	C4, C6, C8 N3, N7, N9

Flow Rate Characteristics

Model	Port size		Flow rate characteristics					
	1, 5, 3 (P, EA, EB)	4, 2 (A, B)	1→4/2 (P→A/B)			4/2→3/5 (A/B→E)		
			C [dm ³ /(s·bar)]	b	Cv	C [dm ³ /(s·bar)]	b	Cv
10-SS5V1-16	C8	C6	0.89	0.22	0.22	0.98	0.21	0.23
10-SS5V2-16	C10	C8	2.3	0.28	0.50	2.7	0.18	0.56

Note) The values are for individually operated 2 position type manifold bases with 5 stations.

Tie-rod base manifold



Manifold Specifications

Applicable series		10-SV1000	10-SV2000	10-SV3000	10-SV4000
Manifold type		Tie-rod base manifold			
1 (P: SUP), 3/5 (E: EXH) type		Common SUP, EXH			
Valve stations (maximum)		20 stations			
Max. number of solenoids		32 points			
Port size	1(P), 3/5(E) port	C8, N9	C10, N11	C12, N11	C12, N11, 03
	4(A), 2(B) port	C3, C4, C6 N1, N3, N7	C4, C6, C8 N3, N7, N9	C6, C8, C10 N7, N9, N11	C8, C10, C12 N9, N11, 02, 03

Flow Rate Characteristics

Model	Port size		Flow rate characteristics					
	1, 5, 3 (P, EA, EB)	4, 2 (A, B)	1→4/2 (P→A/B)			4/2→3/5 (A/B→E)		
			C [dm ³ /(s·bar)]	b	Cv	C [dm ³ /(s·bar)]	b	Cv
10-SS5V1-10	C8	C6	0.98	0.26	0.24	1.1	0.35	0.28
10-SS5V2-10	C10	C8	2.1	0.20	0.46	2.4	0.18	0.48
10-SS5V3-10	C12	C10	4.2	0.22	0.91	4.3	0.21	0.93
10-SS5V4-10	C12	C12	6.2	0.19	1.3	7.0	0.18	1.6

Note) The values are for individually operated 2 position type manifold bases with 5 stations.

Enclosure of Manifold Variations (Common for cassette base and tie-rod base)

Series	Enclosure (Based on IEC529)
EX500 Decentralized serial wiring	IP67 *1
EX250 Serial wiring with input/output unit	IP67
EX600 Serial wiring with input/output unit	IP67 (Manifold assembly)
EX120 Dedicated output serial wiring	Dusttight (IP40)
EX260 Dedicated output serial wiring	IP67 *2
For circular connector	IP67
D-sub connector	Dusttight (IP40)
Flat ribbon cable	Dusttight (IP40)

*1 Enclosure of a gateway unit and input manifold is IP65.

*2 Enclosure is IP40 when the communication connector is D-sub.

Directional Control Valves

Air Cylinders

Rotary Actuators

Air Grippers

Air Preparation Equipment

Modular F. R.

Pressure Control Equipment

Fittings & Tubing

Flow Control Equipment

Pressure Switches/ Pressure Sensors

Series 10-SV Solenoid Valve Specifications



Made to Order
(For details, refer to page 272.)

Symbol

Series 10-SV1000/2000/3000/4000

2 position single

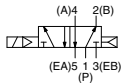

2 position double

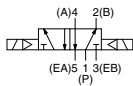

Series 10-SV1000/2000/3000

3 position closed center

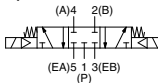

3 position exhaust center



3 position pressure center

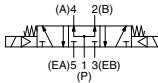

Series 10-SV4000

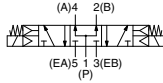
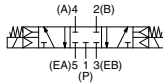

Series 10-SV1000

4 position dual 3 port valve

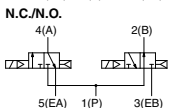
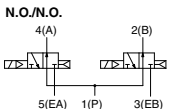
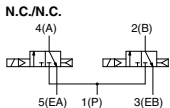

Series 10-SV2000

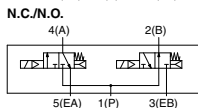
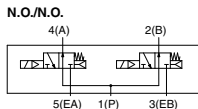
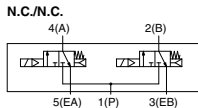

* SV3000 and 4000 are not available with 4 position dual 3 port valve.

Fluid	Air	
Internal pilot operating pressure range (MPa)	2 position single	0.15 to 0.7
	4 position dual 3 port valve	
	2 position double	
External pilot operating pressure range (MPa)	3 position	0.1 to 0.7
	Operating pressure range	
	2 position single, double	
Ambient and fluid temperature (°C)	3 position	-100 kPa to 0.7
		0.25 to 0.7
Max. operating frequency (Hz)	2 position single, double	-10 to 50 (No freezing. Refer to page 680.)
Manual override	4 position dual 3 port valve	
	3 position	
Pilot exhaust method	Non-locking push type	Main/Pilot valve common exhaust
	Push-turn locking slotted type	
Lubrication	Internal pilot	Pilot valve individual exhaust
Mounting orientation	External pilot	
Impact/Vibration resistance (m/s ²)		Not required
Enclosure		Unrestricted
Coil rated voltage		150/30
Allowable voltage fluctuation		IP67 (Based on IEC60529)
Power consumption		24 VDC, 12 VDC
Surge voltage suppressor		±10% of rated voltage
Indicator light		0.6 (With indicator light: 0.65)
		Zener diode
		LED

Note) Impact resistance: No malfunction occurred when it was tested in the axial direction and at right angles to the main valve and armature in both energized and de-energized states once for each condition. (Default settings)

Vibration resistance: No malfunction occurred in a one-sweep test between 45 and 2000 Hz. Test was performed in both energized and de-energized states in the axial direction and at right angles to the main valve and armature. (Default settings)

Response Time

Actuation type	Response time (ms) (at the pressure of 0.5 MPa)			
	10-SV1000	10-SV2000	10-SV3000	10-SV4000
2 position single	11 or less	25 or less	28 or less	40 or less
2 position double	10 or less	17 or less	26 or less	40 or less
3 position	18 or less	29 or less	32 or less	82 or less
4 position dual 3 port valve	15 or less	33 or less	—	—

Note) Based on dynamic performance test, JIS B 8375-1981 (Coil temperature: 20°C, at rated voltage)

Weight

Series	Actuation type	Weight (g)
10-SV1000	Single solenoid	66
	Double solenoid	71
	3 position	73
	4 position dual 3 port	71
10-SV2000	Single solenoid	74
	Double solenoid	78
	3 position	83
	4 position dual 3 port	78
10-SV3000	Single solenoid	99
	Double solenoid	102
	3 position	110
10-SV4000	Single solenoid	186
	Double solenoid	190
	3 position	211

Note) Weight of solenoid valve only.

Decentralized Serial Wiring

Series EX500

IP67 compliant

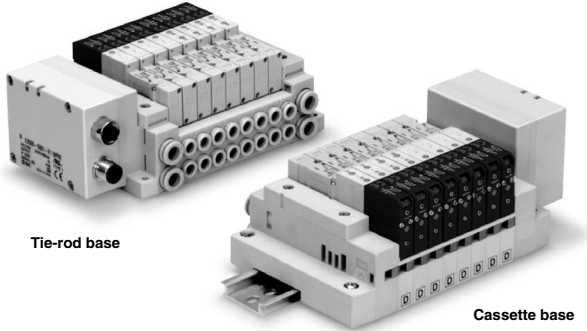

Tie-rod base

Cassette base

Applicable series	Cassette base manifold 10-SV1000/10-SV2000
	Tie-rod base manifold 10-SV1000/10-SV2000/10-SV3000/10-SV4000
<ul style="list-style-type: none"> · Number of outputs: 16 · EX500 gateway unit communication specifications DeviceNet™, PROFIBUS-DP, EtherNet/IP™ 	

Directional Control Valves

Air Cylinders

Rotary Actuators

Air Grippers

Air Preparation Equipment

Modular F. R.

Pressure Control Equipment

Fittings & Tubing

Flow Control Equipment

Pressure Switches/ Pressure Sensors

Series 10-SV

EX500 Decentralized Serial Wiring



How to Order

Series

1	10-SV1000
2	10-SV2000
3	10-SV3000
4	10-SV4000

Tie-rod base
10 - SS5V 1 - W 10S A2W D - 05 U - [] - [] - []

Cassette base
10 - SS5V 1 - W 16S A2W D - 05 U - [] - [] - []

Clean series

1	10-SV1000
2	10-SV2000

Enclosure IP67

SI unit

0	Without SI unit
A2W	DeviceNet™/PROFIBUS DP/ EtherNet/IP™

Valve stations

Symbol	Stations	Note
02	2 stations	Double wiring ^{Note 1)}
:	:	
08	8 stations	Specified layout ^{Note 2)} (up to 16 solenoids possible)
02	2 stations	
:	:	
16	16 stations	

Note 1) Double wiring: Single, double, 3 position and 4 position solenoid valves can be used on all manifold stations. Use of a single solenoid will result in an unused control signal. If this is not desired, order with a specified layout.

Note 2) Specified layout: Indicate wiring specifications on the manifold specification sheet. (Note that double, 3 position and 4 position valves cannot be used where single solenoid wiring has been specified.)

P, E port location

U	U side (2 to 10 stations)
D	D side (2 to 10 stations)
B	Both sides (2 to 16 stations)

SUP/EXH block assembly

Nil	Internal pilot
R	External pilot

Mounting

Nil	Direct mounting
D	DIN rail mounting (with DIN rail)
DO ^{Note)}	DIN rail mounting (without DIN rail)
D3	For 3 stations (When a longer DIN rail is desired than the specified stations. (Specify a longer rail than the standard length.)
:	:
D16	For 16 stations (Specify a longer rail than the standard length.)

DIN rail length specified

Nil	Standard length
3	For 3 stations (Specify a longer rail than the standard length.)
:	:
16	For 16 stations (Specify a longer rail than the standard length.)

A, B port size (Metric)

Symbol	A, B port	P, E port	Applicable series
C3	ø3.2 One-touch fitting	ø8 One-touch fitting	10-SV1000
C4	ø4 One-touch fitting		
C6	ø6 One-touch fitting		
C4	ø4 One-touch fitting	ø10 One-touch fitting	10-SV2000
C6	ø6 One-touch fitting		
C8	ø8 One-touch fitting		
C6	ø6 One-touch fitting	ø12 One-touch fitting	10-SV3000
C8	ø8 One-touch fitting		
C10	ø10 One-touch fitting		
C8	ø8 One-touch fitting	ø12 One-touch fitting	10-SV4000
C10	ø10 One-touch fitting		
C12	ø12 One-touch fitting		
02	Rc 1/4	Rc 3/8	
03	Rc 3/8		
02F	G 1/4		
03F	G 3/8	G 3/8	
M	Mixed		

A, B port size (Inch)

Symbol	A, B port	P, E port	Applicable series
N1	ø1/8" One-touch fitting	ø5/16" One-touch fitting	10-SV1000
N3	ø5/32" One-touch fitting		
N7	ø1/4" One-touch fitting		
N3	ø5/32" One-touch fitting	ø3/8" One-touch fitting	10-SV2000
N7	ø1/4" One-touch fitting		
N9	ø5/16" One-touch fitting		
N7	ø1/4" One-touch fitting	ø3/8" One-touch fitting	10-SV3000
N9	ø5/16" One-touch fitting		
N11	ø3/8" One-touch fitting		
N9	ø5/16" One-touch fitting	ø3/8" One-touch fitting	10-SV4000
N11	ø3/8" One-touch fitting		
02N	NPT 1/4		
03N	NPT 3/8	NPTF 3/8	
02T	NPTF 1/4		
03T	NPTF 3/8		
M	Mixed		

* For mixed specifications (M), indicate separately on the manifold specification sheet.
 * External pilot type (R) X, PE port sizes are ø4 (metric), ø5/32" (inch) for the 10-SV1000/2000 series and ø6 (metric), ø1/4" (inch) for the 10-SV3000/4000 series.

How to Order Valve Manifold Assembly

Ordering example (10-SV1000)

Manifold

10-SS5V1-W16SA2WD-06B-C6 (1 set)

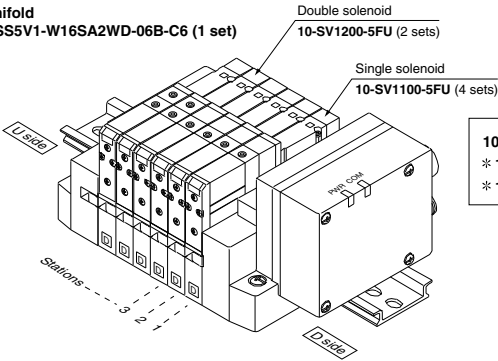

- 10-SS5V1-W16SA2WD-06B-C6.....1 set (Manifold part no.)
- * 10-SV1100-5FU.....4 sets (Single solenoid part no.)
- * 10-SV1200-5FU.....2 sets (Double solenoid part no.)

How to Order Solenoid Valve

10 - SV 1 1 00 - 5 F -

Clean series

Series

1	10-SV1000
2	10-SV2000
3	10-SV3000
4	10-SV4000

Actuation type

1	2 position single solenoid
2	2 position double solenoid
3	3 position closed center
4	3 position exhaust center
5	3 position pressure center
A	4 position dual 3 port valve: N.C./N.C.
B	4 position dual 3 port valve: N.O./N.O.
C	4 position dual 3 port valve: N.C./N.O.

* 4 position dual 3 port valves are applicable to the 10-SV1000 and 10-SV2000 series only.

Pilot type

Nil	Internal pilot
R	External pilot

* External pilot specifications are not available for 4 position dual 3 port valves.

Back pressure check valve

Nil	None
K	Built-in

* The built-in back pressure check valve type is applicable to the 10-SV1000 series only.

* The product with back pressure check valve is not available for 3 position solenoid valves.

Made to Order

Nil	—
X90	Main valve fluororubber (Refer to page 272.)

Manual override

Nil:	Non-locking push type
D:	Push-turn locking slotted type

Light/surge voltage suppressor

U	With light/surge voltage suppressor
R	With surge voltage suppressor

Rated voltage

5	24 VDC
---	--------

Note) Refer to the Specific Product Precautions 2 on page 274.

Directional Control Valves

Air Cylinders

Rotary Actuators

Air Grippers

Air Preparation Equipment

Modular F. R.

Pressure Control Equipment

Fittings & Tubing

Flow Control Equipment

Pressure Switches/ Pressure Sensors

Dimensions: Series 10-SV1000 for EX500 Decentralized Serial Wiring

• **Cassette base manifold: 10-SS5V1-W16SA2WD-**

U	D
(R)	(R)

C3, N1
C4, N3
C6, N7

- When P, E port outlets are indicated on the U side or D side, the P, E ports on the opposite side are plugged.
- External pilot port positions are the same as P, E port outlet positions.

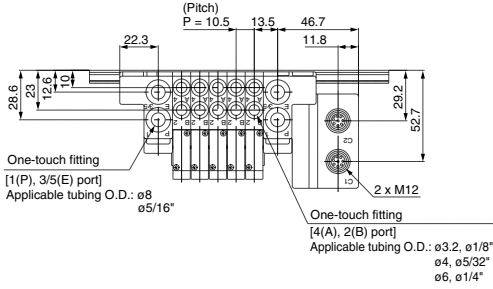

With external pilot specifications

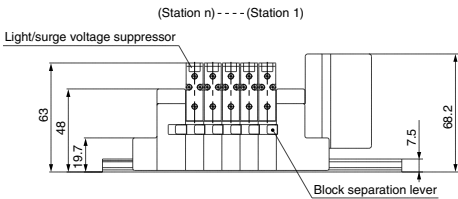
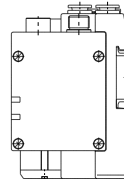
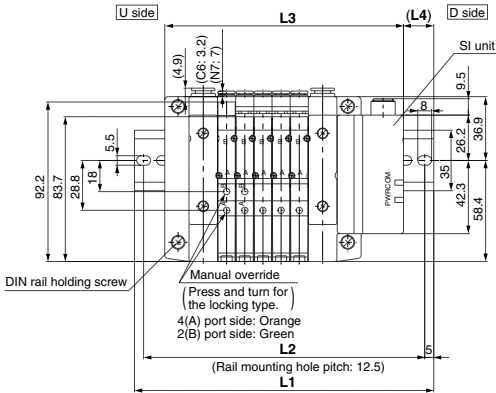
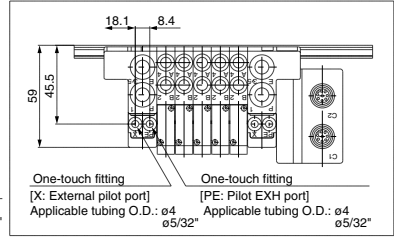

With option

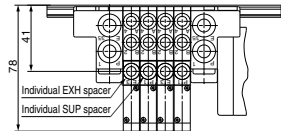

L Dimension

n	2	3	4	5	6	7	8	9	10	11	12	13	14	15	16	n: Stations
L1	135.5	148	160.5	173	173	185.5	198	210.5	223	235.5	235.5	248	260.5	273	285.5	
L2	125	137.5	150	162.5	162.5	175	187.5	200	212.5	225	225	237.5	250	262.5	275	
L3	106.5	117	127.5	138	148.5	159	169.5	180	190.5	201	211.5	222	232.5	243	253.5	
L4	14.5	15.5	16.5	17.5	12.5	13.5	14.5	15.5	16.5	17.5	12	13	14	15	16	

Dimensions: Series 10-SV2000 for EX500 Decentralized Serial Wiring

• **Cassette base manifold: 10-SS5V2-W16SA2WD-**

U	D
R	B

(Stations)

C4, N3
C6, N7
C8, N9

- When P, E port outlets are indicated on the U side or D side, the P, E ports on the opposite side are plugged.
- External pilot port positions are the same as P, E port outlet positions.

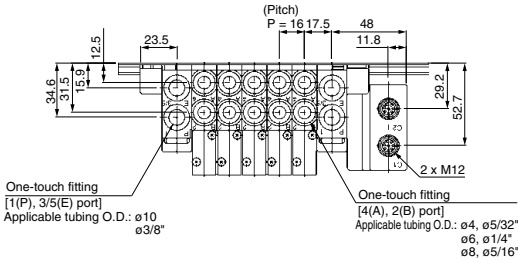

With external pilot specifications

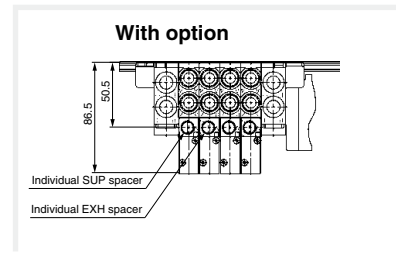
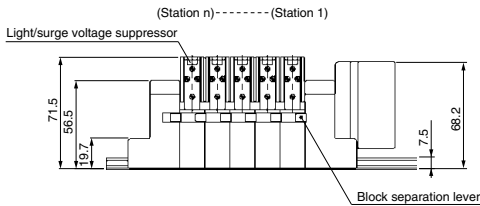
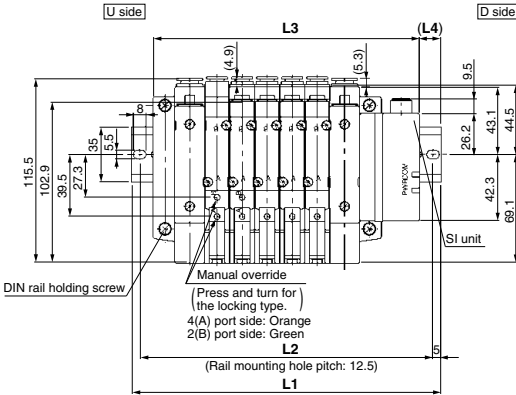
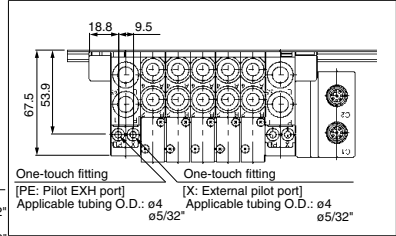

L Dimension

n	2	3	4	5	6	7	8	9	10	11	12	13	14	15	16	n: Stations
L1	148	173	185.5	198	210.5	235.5	248	260.5	285.5	298	310.5	323	348	360.5	373	
L2	137.5	162.5	175	187.5	200	225	237.5	250	275	287.5	300	312.5	337.5	350	362.5	
L3	122.5	138.5	154.5	170.5	186.5	202.5	218.5	234.5	250.5	266.5	282.5	298.5	314.5	330.5	346.5	
L4	13	17.5	15.5	14	12	16.5	15	13	17.5	16	14	12.5	17	15	13.5	

Directional Control Valves

Air Cylinders

Rotary Actuators

Air Grippers

Air Preparation Equipment

Modular F. R.

Pressure Control Equipment

Fittings & Tubing

Flow Control Equipment

Pressure Switches/ Pressure Sensors

Dimensions: Series 10-SV1000 for EX500 Decentralized Serial Wiring

• Tie-rod base manifold: 10-SS5V1-W10SA2WD-Stations $\begin{matrix} U \\ D \end{matrix}$ (R)- $\begin{matrix} C3, N1 \\ C4, N3 \\ C6, N7 \end{matrix}$ (-D)

- When P, E port outlets are indicated on the U side or D side, the P, E ports on the opposite side are plugged.
- External pilot port positions are the same as P, E port outlet positions.

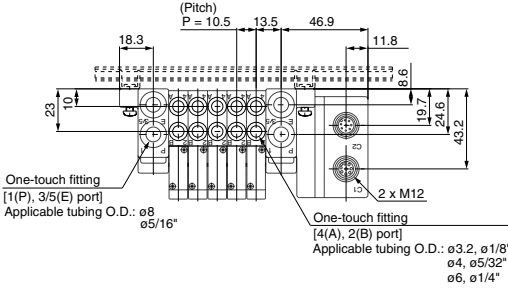

With external pilot specifications

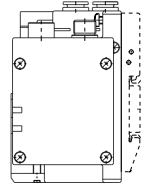
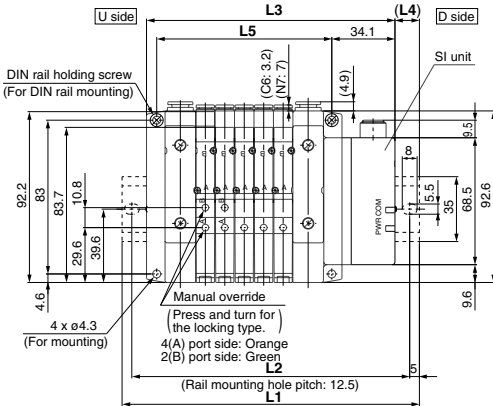
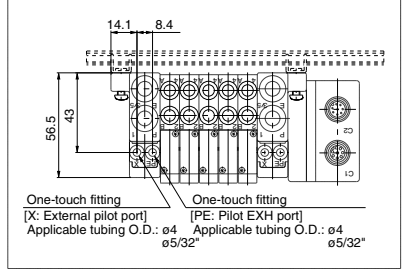

With option

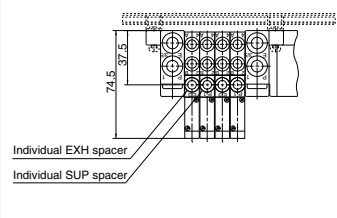

L Dimension

n: Stations

L	n	2	3	4	5	6	7	8	9	10	11	12	13	14	15	16
L1		135.5	148	148	160.5	173	185.5	198	210.5	210.5	223	235.5	248	260.5	273	273
L2		125	137.5	137.5	150	162.5	175	187.5	200	200	212.5	225	237.5	250	262.5	262.5
L3		102.6	113.1	123.6	134.1	144.6	155.1	165.6	176.1	186.6	197.1	207.6	218.1	228.6	239.1	249.6
L4		16.5	17.5	12	13	14	15	16	17	12	13	14	15	16	17	11.5
L5		63	73.5	84	94.5	105	115.5	126	136.5	147	157.5	168	178.5	189	199.5	210

Dimensions: Series 10-SV2000 for EX500 Decentralized Serial Wiring

• Tie-rod base manifold: 10-SS5V2-W10SA2WD-**Stations** $\begin{matrix} U \\ D \end{matrix}$ **(R)-** $\begin{matrix} C4, N3 \\ C6, N7 \\ C8, N9 \end{matrix}$ **(-D)**

- When P, E port outlets are indicated on the U side or D side, the P, E ports on the opposite side are plugged.
- External pilot port positions are the same as P, E port outlet positions.

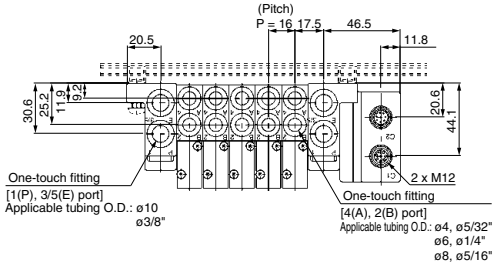

With external pilot specifications

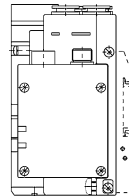
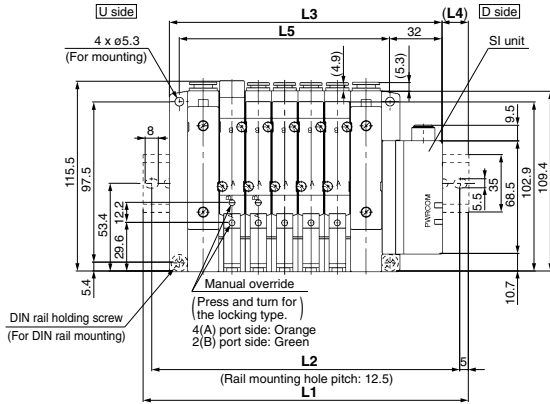
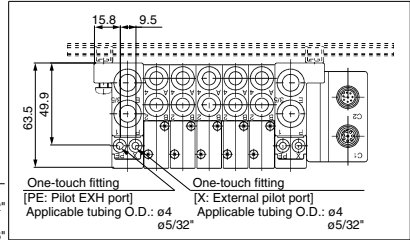

With option

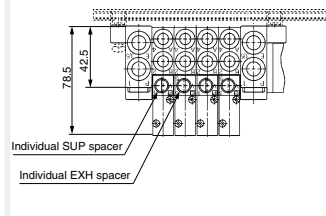
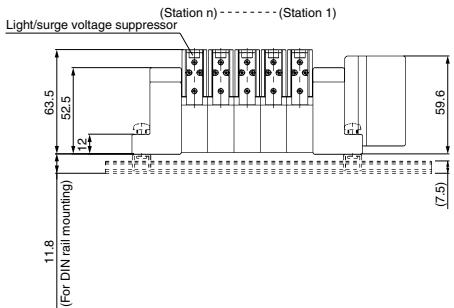

L Dimension

n: Stations

n	2	3	4	5	6	7	8	9	10	11	12	13	14	15	16
L1	148	160.5	185.5	198	210.5	223	248	260.5	273	285.5	310.5	323	335.5	360.5	373
L2	137.5	150	175	187.5	200	212.5	237.5	250	262.5	275	300	312.5	325	350	362.5
L3	118	134	150	166	182	198	214	230	246	262	278	294	310	326	342
L4	15	13.5	18	16	14.5	12.5	17	15.5	13.5	12	16.5	14.5	13	17.5	15.5
L5	80	96	112	128	144	160	176	192	208	224	240	256	272	288	304

Directional Control Valves
Air Cylinders
Rotary Actuators
Air Grippers
Air Preparation Equipment
Modular F. R.
Pressure Control Equipment
Fittings & Tubing
Flow Control Equipment
Pressure Switches/ Pressure Sensors

Dimensions: Series 10-SV3000 for EX500 Decentralized Serial Wiring

• Tie-rod base manifold: 10-SS5V3-W10SA2WD-**Stations** $\begin{matrix} U \\ D \end{matrix}$ **(R)-** $\begin{matrix} C6, N7 \\ C8, N9 \\ C10, N11 \end{matrix}$ **(-D)**

- When P, E port outlets are indicated on the U side or D side, the P, E ports on the opposite side are plugged.
- External pilot port positions are the same as P, E port outlet positions.

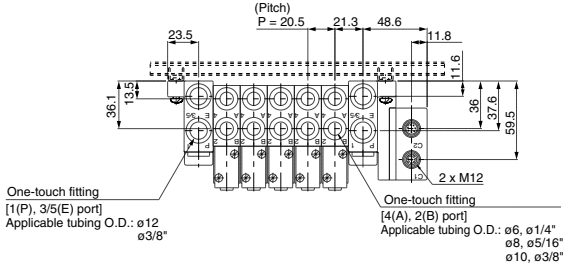

With external pilot specifications

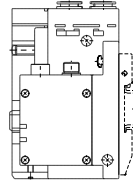
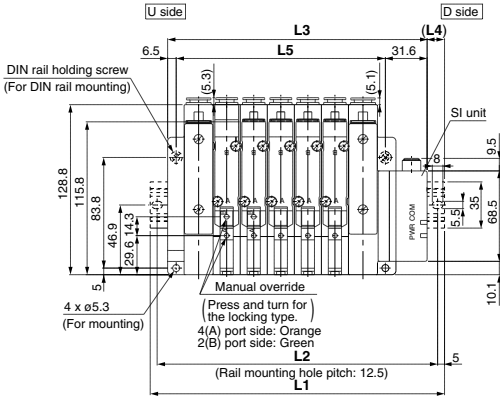
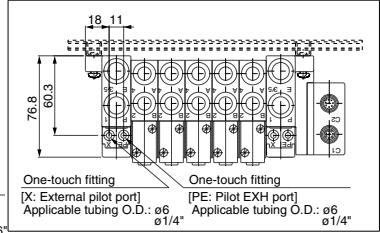

With option

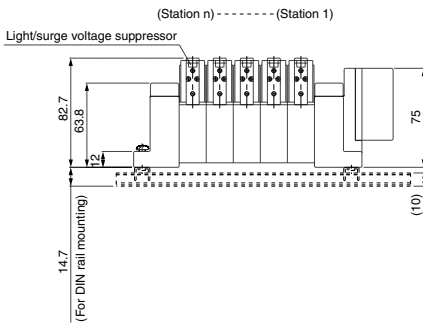
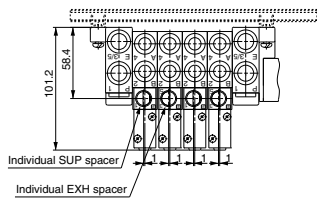

L Dimension

n: Stations

n	2	3	4	5	6	7	8	9	10	11	12	13	14	15	16
L1	160.5	185.5	210.5	223	248	273	285.5	310.5	323	348	373	385.5	410.5	435.5	448
L2	150	175	200	212.5	237.5	262.5	275	300	312.5	337.5	362.5	375	400	425	437.5
L3	135.1	155.6	176.1	196.6	217.1	237.6	258.1	278.6	299.1	319.6	340.1	360.6	381.1	401.6	422.1
L4	12.5	15	17	13	15.5	17.5	13.5	16	12	14	16.5	12.5	14.5	17	13
L5	97	117.5	138	158.5	179	199.5	220	240.5	261	281.5	302	322.5	343	363.5	384

Dimensions: Series 10-SV4000 for EX500 Decentralized Serial Wiring

• Tie-rod base manifold: 10-SS5V4-W10SA2WD- Stations $\begin{matrix} U \\ D \end{matrix}$ (R)- $\begin{matrix} 02 \\ 03 \end{matrix}$ C8, N9 C10, N11 (-D)

- When P, E port outlets are indicated on the U side or D side, the P, E ports on the opposite side are plugged.
- External pilot port positions are the same as P, E port outlet positions.

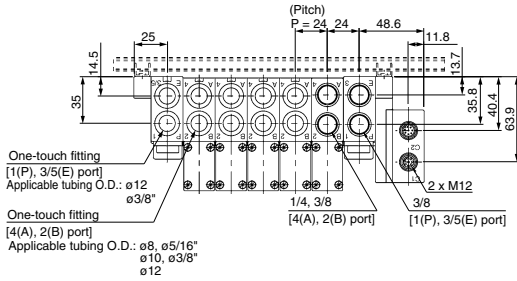

With external pilot specifications

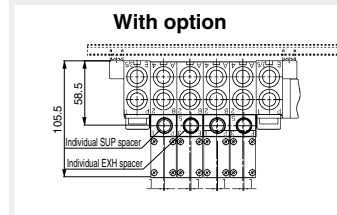
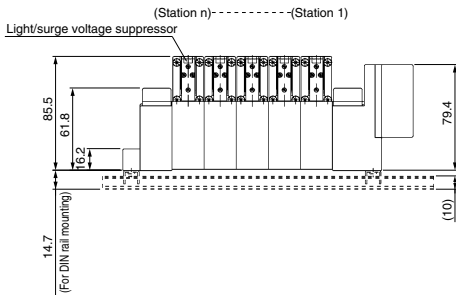
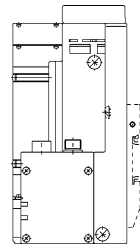
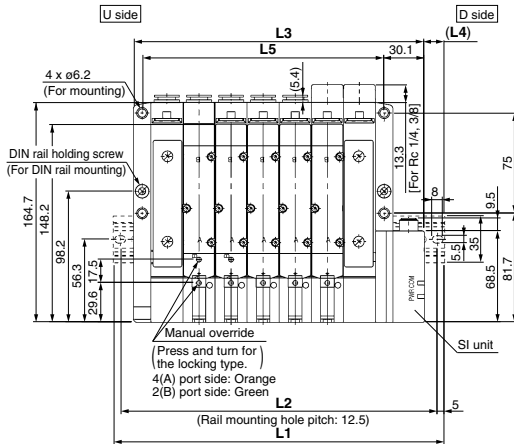
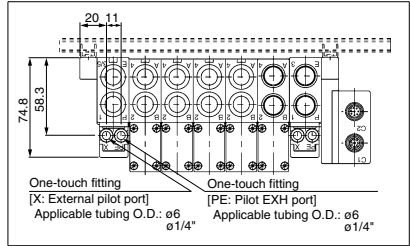

L Dimension

	n: Stations															
n	2	3	4	5	6	7	8	9	10	11	12	13	14	15	16	
L1	173	198	223	248	273	298	323	348	373	385.5	410.5	435.5	460.5	485.5	510.5	
L2	162.5	187.5	212.5	237.5	262.5	287.5	312.5	337.5	362.5	375	400	425	450	475	500	
L3	145.6	169.6	193.6	217.6	241.6	265.6	289.6	313.6	337.6	361.6	385.6	409.6	433.6	457.6	481.6	
L4	13.5	14	14.5	15	15.5	16	16.5	17	17.5	12	12.5	13	13.5	14	14.5	
L5	109	133	157	181	205	229	253	277	301	325	349	373	397	421	445	

Directional Control Valves
Air Cylinders
Rotary Actuators
Air Grippers
Air Preparation Equipment
Modular F. R.
Pressure Control Equipment
Fittings & Tubing
Flow Control Equipment
Pressure Switches/ Pressure Sensors

Serial Wiring with Input/Output Unit

Series EX250

IP67 compliant

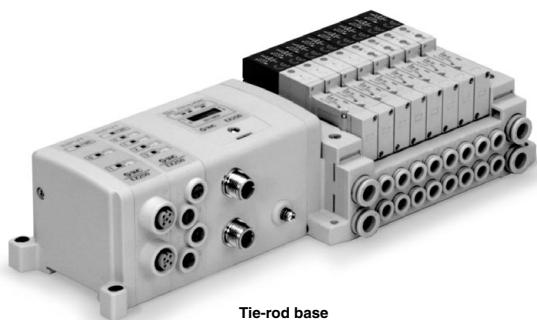

Applicable series	Tie-rod base manifold 10-SV1000/10-SV2000/10-SV3000
	· Number of inputs/outputs: 32 each

Directional
Control Valves

Air Cylinders

Rotary Actuators

Air Grippers

Air Preparation
Equipment

Modular F. R.

Pressure Control
Equipment

Fittings & Tubing

Flow Control
Equipment

Pressure Switches/
Pressure Sensors

Series 10-SV

EX250 Serial Wiring with Input/Output Unit



How to Order

• Tie-rod base

10 - SS5V **1** - W10S1 **QW** **□** **□** **□** **□** **D** - **05** **U** **□** - **□** - **□**

• Clean series

• Series

1	SV1000
2	SV2000
3	SV3000

• Enclosure
IP67

• Input block stations

Nil	None
1	1 station
:	:
8	8 stations

(Note) The symbol is nil for no SI unit.

• Input block type

Nil	Without input block	
1	M12, 2 inputs	EX250-IE1
2	M12, 4 inputs	EX250-IE2
3	M8, 4 inputs	EX250-IE3

(Note) The symbol is nil for no SI unit.

• Input block specifications

Nil	PNP input (+COM) or without input block
N	NPN input (-COM)

• Valve stations

Symbol	Stations	Note
02	2 stations	Double wiring (Note 1)
:	:	
16	16 stations	Specified layout (Note 2) (Up to 32 solenoids possible)
02	2 stations	
:	:	
20	20 stations	

• When the SI unit is for AS-i, the maximum numbers of solenoids are as follows.

TAW, TCW: Maximum 8 solenoids
TBW, TDW: Maximum 4 solenoids

Note 1) Double wiring: Single, double, 3 position and 4 position solenoid valves can be used on all manifold stations. Use of a single solenoid will result in an unused control signal. If this is not desired, order with a specified layout.

Note 2) Specified layout: Indicate wiring specifications on the manifold specification sheet. (Note that double, 3 position and 4 position valves cannot be used where single solenoid wiring has been specified.)

• SI unit

Symbol	Protocol type
W10S10	Without SI unit
W10S1QW	DeviceNet™
W10S1NW	PROFIBUS DP
W10S1VW	CC-Link
W10S1TAW	AS-Interface (8 in/8 out, 31 slave modes, 2 power supply systems)
W10S1TBW	AS-Interface (4 in/4 out, 31 slave modes, 2 power supply systems)
W10S1TCW (Note)	AS-Interface (8 in/8 out, 31 slave modes, 1 power supply system)
W10S1TDW (Note)	AS-Interface (4 in/4 out, 31 slave modes, 1 power supply system)
W10S1YW	CANopen
W10S1ZEN	EtherNet/IP™

• Input blocks cannot be mounted without SI unit.

• When the DIN rail is included without an SI unit, the DIN rail length will accommodate an SI unit and one input block.

Note) There is a limit to the supply current to the input block and valve from SI units that have AS-Interface-compliant 1 power supply system. For details, refer to the [WEB catalog](#).

• P, E port location

U	U side (2 to 10 stations)
D	D side (2 to 10 stations)
B	Both sides (2 to 20 stations)

• SUP/EXH block assembly

Nil	Internal pilot
R	External pilot

• A, B port size (Metric)

Symbol	A, B port	P, E port	Applicable series
C3	ø3.2 One-touch fitting	ø8 One-touch fitting	10-SV1000
C4	ø4 One-touch fitting		
C6	ø6 One-touch fitting		
C4	ø4 One-touch fitting	ø10 One-touch fitting	10-SV2000
C6	ø6 One-touch fitting		
C8	ø8 One-touch fitting		
C6	ø6 One-touch fitting	ø12 One-touch fitting	10-SV3000
C8	ø8 One-touch fitting		
C8	ø8 One-touch fitting		
C10	ø10 One-touch fitting		
M	Mixed		

• A, B port size (Inch)

Symbol	A, B port	P, E port	Applicable series
N1	ø1/8" One-touch fitting	ø5/16" One-touch fitting	10-SV1000
N3	ø5/32" One-touch fitting		
N7	ø1/4" One-touch fitting		
N3	ø5/32" One-touch fitting	ø3/8" One-touch fitting	10-SV2000
N7	ø1/4" One-touch fitting		
N9	ø5/16" One-touch fitting		
N9	ø1/4" One-touch fitting	ø3/8" One-touch fitting	10-SV3000
N9	ø5/16" One-touch fitting		
N11	ø3/8" One-touch fitting		
M	Mixed		

• Mounting

Nil	Direct mounting
D	DIN rail mounting (With DIN rail)
D0™	DIN rail mounting (Without DIN rail)
D3	For 3 stations: When a longer DIN rail is desired than the specified stations
:	:
D20	For 20 stations: (Specify a longer rail than the standard length.)

Note) For D0, only DIN rail mounting bracket is attached.

* For mixed specifications (M), indicate separately on the manifold specification sheet.

* External pilot type (R) X, PE port sizes are ø4 (metric), ø5/32" (inch) for the 10-SV1000/2000 series and ø6 (metric), ø1/4" (inch) for the 10-SV3000 series.

How to Order Valve Manifold Assembly

Ordering example (10-SV1000)

Manifold

10-SS5V1-W10S1QW11ND-05B-C6 (1 set)

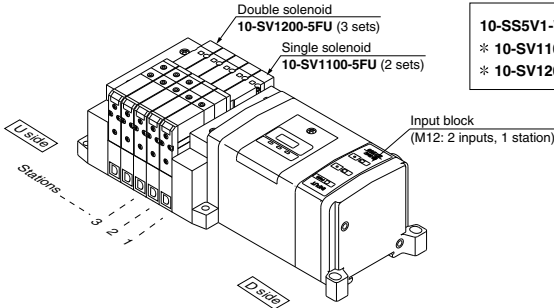

10-SS5V1-W10S1QW11ND-05B-C6.....1 set (Manifold part no.)
 * **10-SV1100-5FU**.....2 sets (Single solenoid part no.)
 * **10-SV1200-5FU**.....3 sets (Double solenoid part no.)

How to Order Solenoid Valve

10 - SV 1 1 00 - 5 F - (Note)

Clean series

Series

1	10-SV1000
2	10-SV2000
3	10-SV3000

Actuation type

1	2 position single solenoid
2	2 position double solenoid
3	3 position closed center
4	3 position exhaust center
5	3 position pressure center
A	4 position dual 3 port valve: N.C./N.C.
B	4 position dual 3 port valve: N.O./N.O.
C	4 position dual 3 port valve: N.C./N.O.

* 4 position dual 3 port valves are applicable to the 10-SV1000/10-SV2000 series only.

Pilot type

Nil	Internal pilot
R	External pilot

* External pilot specifications are not available for 4 position dual 3 port valves.

Back pressure check valve

Nil	None
K	Built-in

* The built-in back pressure check valve type is applicable to the 10-SV1000 series only.
 * The product with back pressure check valve is not available for 3 position valves.

Note) Available with manifold block for station additions. Refer to the **WEB catalog**.

Made to Order

Nil	—
X90	Main valve fluororubber (Refer to page 272.)

Manual override

Nil: Non-locking push type	D: Push-turn locking slotted type
----------------------------	-----------------------------------

Light/surge voltage suppressor

U	With light/surge voltage suppressor
R	With surge voltage suppressor

Rated voltage

5	24 VDC
---	--------

Note) Refer to the Specific Product Precautions 2 on page 274.

Directional Control Valves
 Air Cylinders
 Rotary Actuators
 Air Grippers
 Air Preparation Equipment
 Modular F. R.
 Pressure Control Equipment
 Fittings & Tubing
 Flow Control Equipment
 Pressure Switches/ Pressure Sensors

Dimensions: Series 10-SV1000 for EX250 Serial Wiring with Input/Output Unit

• Tie-rod base manifold: 10-SS5V1-W10S1□□□□D-**Stations** $\begin{matrix} U \\ D \\ B \end{matrix}$ (R)- C3, N1
C4, N3
C6, N7 (-D)

• When P, E port outlets are indicated on the U side or D side, the P, E ports on the opposite side are plugged.
• External pilot port positions are the same as P, E port outlet positions.

(With 2 Input blocks)

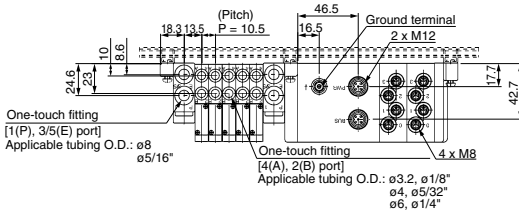

With external pilot specifications

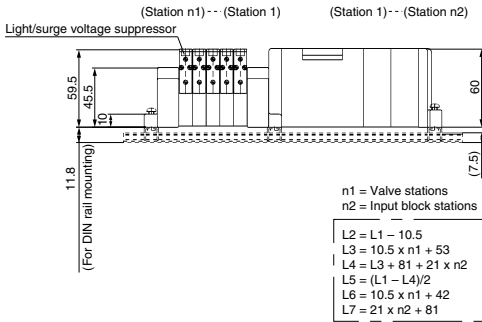
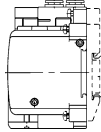
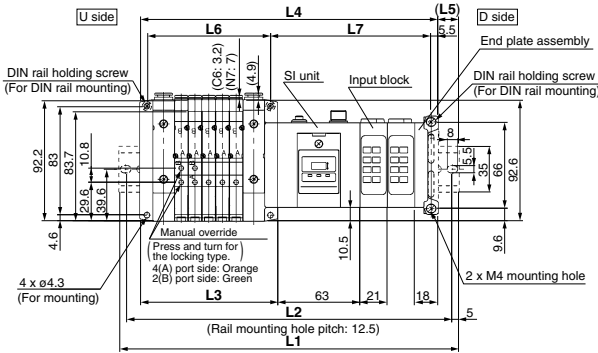
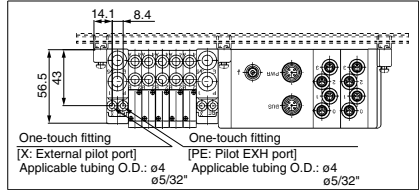

n1 = Valve stations
n2 = Input block stations

L2 = L1 - 10.5
L3 = 10.5 x n1 + 53
L4 = L3 + 81 + 21 x n2
L5 = (L1 - L4) / 2
L7 = 21 x n2 + 81

With option

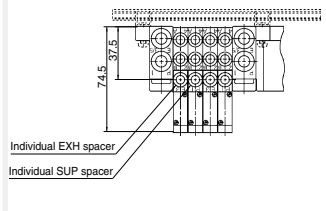

L1: DIN rail overall length

Valve stations (n1) Input block stations (n2)	2	3	4	5	6	7	8	9	10	11	12	13	14	15	16	17	18	19	20
0	185.5	198	210.5	210.5	223	235.5	248	260.5	273	273	285.5	298	310.5	323	335.5	348	348	360.5	373
1	210.5	210.5	223	235.5	248	260.5	273	273	285.5	298	310.5	323	335.5	348	348	360.5	373	385.5	398
2	223	235.5	248	260.5	273	273	285.5	298	310.5	323	335.5	348	348	360.5	373	385.5	398	410.5	410.5
3	248	260.5	273	273	285.5	298	310.5	323	335.5	348	348	360.5	373	385.5	398	410.5	410.5	423	435.5
4	273	273	285.5	298	310.5	323	335.5	348	348	360.5	373	385.5	398	410.5	410.5	423	435.5	448	460.5
5	285.5	298	310.5	323	335.5	348	348	360.5	373	385.5	398	410.5	410.5	423	435.5	448	460.5	473	473
6	310.5	323	335.5	348	348	360.5	373	385.5	398	410.5	410.5	423	435.5	448	460.5	473	473	485.5	498
7	335.5	348	348	360.5	373	385.5	398	410.5	410.5	423	435.5	448	460.5	473	473	485.5	498	510.5	523
8	348	360.5	373	385.5	398	410.5	410.5	423	435.5	448	460.5	473	473	485.5	498	510.5	523	535.5	535.5

Dimensions: Series 10-SV2000 for EX250 Serial Wiring with Input/Output Unit

• Tie-rod base manifold: 10-SS5V2-W10S1□□□□D- $\begin{matrix} \text{U} \\ \text{D} \end{matrix}$ Stations $\begin{matrix} \text{R} \\ \text{B} \end{matrix}$ C4, N3 C6, N7 C8, N9 (-D)

(With 2 input blocks)

- When P, E port outlets are indicated on the U side or D side, the P, E ports on the opposite side are plugged.
 - External pilot port positions are the same as P, E port outlet positions.

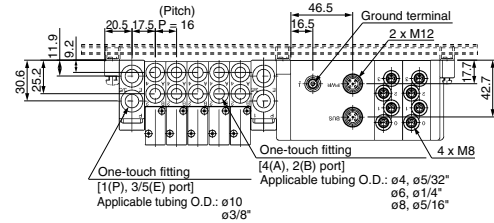

With external pilot specifications

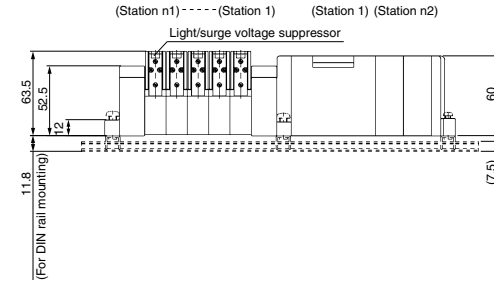
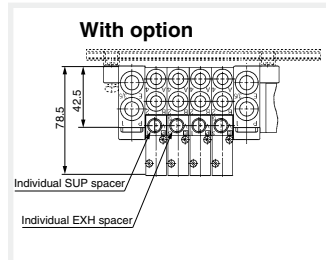
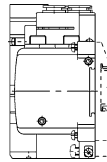
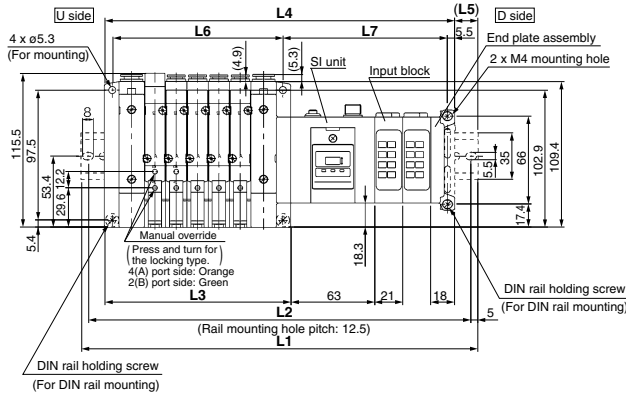
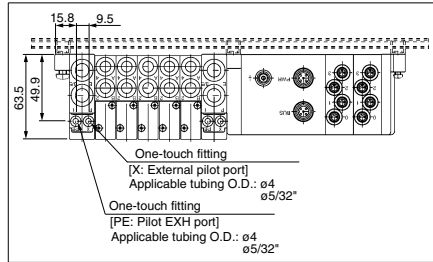

n1 = Valve stations
 n2 = Input block stations

$$\begin{aligned} L2 &= L1 - 10.5 \\ L3 &= 16 \times n1 + 60 \\ L4 &= L3 + 81 + 21 \times n2 \\ L5 &= (L1 - L4)/2 \\ L6 &= 16 \times n1 + 48 \\ L7 &= 21 \times n2 + 81.5 \end{aligned}$$

L1: DIN rail overall length

Valve stations (n1) Input block stations (n2)	2	3	4	5	6	7	8	9	10	11	12	13	14	15	16	17	18	19	20
0	198	223	235.5	248	260.5	285.5	298	310.5	335.5	348	360.5	373	398	410.5	423	448	460.5	473	485.5
1	223	235.5	260.5	273	285.5	298	323	335.5	348	373	385.5	398	410.5	435.5	448	460.5	485.5	498	510.5
2	248	260.5	273	298	310.5	323	335.5	360.5	373	385.5	410.5	423	435.5	448	473	485.5	498	510.5	535.5
3	260.5	285.5	298	310.5	335.5	348	360.5	373	398	410.5	423	435.5	460.5	473	485.5	510.5	523	535.5	548
4	285.5	298	323	335.5	348	360.5	385.5	398	410.5	435.5	448	460.5	473	498	510.5	523	548	560.5	573
5	310.5	323	335.5	360.5	373	385.5	398	423	435.5	448	473	485.5	498	510.5	535.5	548	560.5	585.5	598
6	323	348	360.5	373	398	410.5	423	435.5	460.5	473	485.5	510.5	523	535.5	548	573	585.5	598	610.5
7	348	360.5	385.5	398	410.5	435.5	448	460.5	473	498	510.5	523	535.5	560.5	573	585.5	610.5	623	635.5
8	373	385.5	398	423	435.5	448	460.5	485.5	498	510.5	535.5	548	560.5	573	598	610.5	623	648	660.5

Dimensions: Series 10-SV3000 for EX250 Serial Wiring with Input/Output Unit

• Tie-rod base manifold: 10-SS5V3-W10S1□□□□D-**Stations** $\begin{matrix} U \\ D \\ B \end{matrix}$ (R)- $\begin{matrix} C6, N7 \\ C8, N9 \\ C10, N11 \end{matrix}$ (-D)

(With 2 input blocks)

• When P, E port outlets are indicated on the U side or D side, the P, E ports on the opposite side are plugged.
• External pilot port positions are the same as P, E port outlet positions.

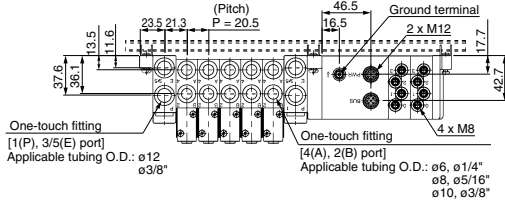

With external pilot specifications

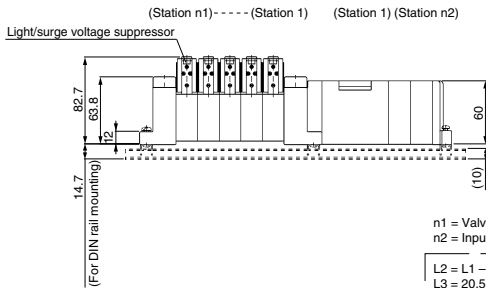
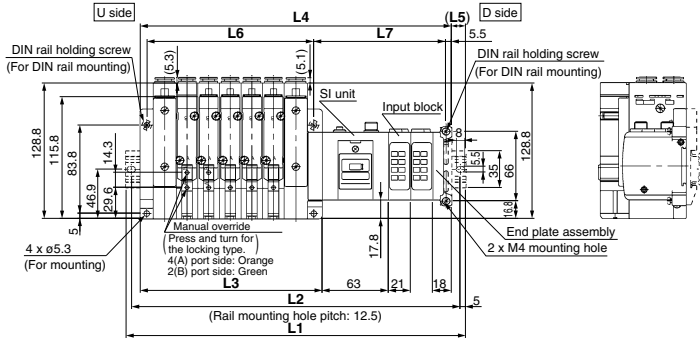
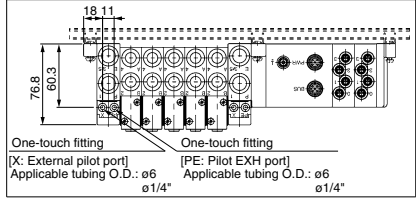

n1 = Valve stations
n2 = Input block stations

$$\begin{aligned} L2 &= L1 - 10.5 \\ L3 &= 20.5 \times n1 + 70.5 \\ L4 &= L3 + 81 + 21 \times n2 \\ L5 &= (L1 - L4) / 2 \\ L6 &= 20.5 \times n1 + 56 \\ L7 &= 21 \times n2 + 83.5 \end{aligned}$$

With option

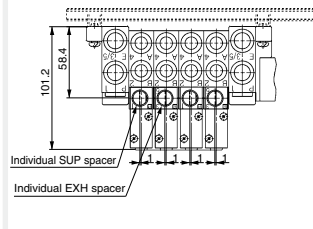

L1: DIN rail overall length

Valve stations (n1) Input block stations (n2)	2	3	4	5	6	7	8	9	10	11	12	13	14	15	16	17	18	19	20
0	223	248	260.5	285.5	298	323	348	360.5	385.5	410.5	423	448	473	485.5	510.5	535.5	548	573	585.5
1	248	260.5	285.5	310.5	323	348	360.5	385.5	410.5	423	448	473	485.5	510.5	535.5	548	573	585.5	610.5
2	260.5	285.5	310.5	323	348	360.5	385.5	410.5	423	448	473	485.5	510.5	535.5	548	573	598	610.5	635.5
3	285.5	310.5	323	348	373	385.5	410.5	423	448	473	485.5	510.5	535.5	548	573	598	610.5	635.5	648
4	310.5	323	348	373	385.5	410.5	423	448	473	485.5	510.5	535.5	548	573	598	610.5	635.5	660.5	673
5	323	348	373	385.5	410.5	435.5	448	473	485.5	510.5	535.5	548	573	598	610.5	635.5	660.5	673	698
6	348	373	385.5	410.5	435.5	448	473	485.5	510.5	535.5	548	573	598	610.5	635.5	660.5	673	698	723
7	373	385.5	410.5	435.5	448	473	498	510.5	535.5	548	573	598	610.5	635.5	660.5	673	698	723	735.5
8	385.5	410.5	435.5	448	473	498	510.5	535.5	548	573	598	610.5	635.5	660.5	673	698	723	735.5	760.5

Integrated Type (For Input/Output) Serial Transmission System

Series **EX600**

IP67 compliant

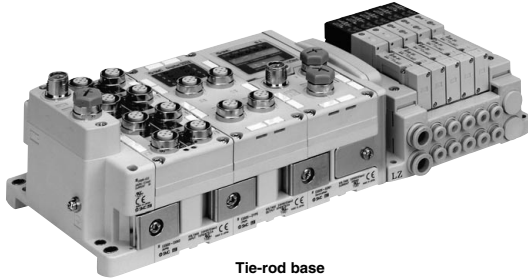

Tie-rod base

Applicable series	Tie-rod base manifold 10-SV1000/10-SV2000/10-SV3000
	<ul style="list-style-type: none">· Digital inputs/outputs: Max. 144/144· Analog input: Max. 18 channels· Number of valve outputs: 32

Directional
Control Valves

Air Cylinders

Rotary Actuators

Air Grippers

Air Preparation
Equipment

Modular F. R.

Pressure Control
Equipment

Fittings & Tubing

Flow Control
Equipment

Pressure Switches/
Pressure Sensors

Series 10-SV

EX600 Integrated-type (For Input/Output) Serial Transmission System



When I/O Unit EX600-D□□E or EX600-D□□F are selected, enclosure is IP40.
For details, refer to the **WEB catalog**.

How to Order Manifold

● Tie-rod base

10-SS5V 1 - 10S6 Q - D-05 U - C6 -

Series

1	10-SV1000
2	10-SV2000
3	10-SV3000

Enclosure

Nil	IP40
W	IP67

SI Unit

0	Without SI Unit
Q	DeviceNet™
N	PROFIBUS DP
V	CC-Link
ZE	EtherNet/IP™
D	EtherCAT

- When "Without SI Unit" is specified, I/O Unit cannot be mounted.
- When "Without SI Unit" is specified, a valve plate which connects the valve manifold and SI Unit, is not mounted. Refer to the **WEB catalog** for mounting method.

End plate type

Nil	No end plate
2	Power supply with M12 connector (Max. supplied current 2 A)
3	Power supply with 7/8 inch connector (Max. supplied current 8 A)

Note) The symbol is nil for no SI Unit.

SI Unit common

Nil	Positive common
N	Negative common

Note) The symbol is nil for no SI Unit.

I/O Unit stations

Nil	None
1	1 station
⋮	⋮
9	9 stations

- Note 1) The symbol is nil for no SI Unit.
Note 2) SI Unit is not included in I/O Unit stations.
Note 3) When I/O Unit is selected, it is shipped separately and assembled by users. Refer to the attached operation manual for mounting method.

Valve stations

Symbol	Stations	Note
02	2 stations	Double wiring ^{Note 1)}
⋮	⋮	
16	16 stations	
02	2 stations	Specified layout ^{Note 2)} (Available up to 32 solenoids)
⋮	⋮	
20	20 stations	

- Note 1) Double wiring: Single, double, 3-position and 4-position valves can be used on all manifold stations.
Use of a single solenoid will result in an unused control signal. If this is not desired, order with a specified layout.
Note 2) Specified layout: Indicate the wiring specifications on the manifold specification sheet. (Note that double, 3-position and 4-position valves cannot be used where single wiring has been specified.)

A, B port size (Metric)

Symbol	A, B port	P, E port	Applicable series
C3	ø3.2 One-touch fitting	ø8 One-touch fitting	10-SV1000
C4	ø4 One-touch fitting		
C6	ø6 One-touch fitting		
C4	ø4 One-touch fitting	ø10 One-touch fitting	10-SV2000
C6	ø6 One-touch fitting		
C8	ø8 One-touch fitting		
C6	ø6 One-touch fitting	ø12 One-touch fitting	10-SV3000
C8	ø8 One-touch fitting		
C10	ø10 One-touch fitting		
M	Mixed		

A, B port size (Inch)

Symbol	A, B port	P, E port	Applicable series
N1	ø1/8" One-touch fitting	ø5/16" One-touch fitting	10-SV1000
N3	ø5/32" One-touch fitting		
N7	ø1/4" One-touch fitting		
N3	ø5/32" One-touch fitting	ø3/8" One-touch fitting	10-SV2000
N7	ø1/4" One-touch fitting		
N9	ø5/16" One-touch fitting		
N7	ø1/4" One-touch fitting	ø3/8" One-touch fitting	10-SV3000
N9	ø5/16" One-touch fitting		
N11	ø3/8" One-touch fitting		
M	Mixed		

* For mixed specifications (M), indicate separately on the manifold specification sheet.

* External pilot type (R) X, PE port sizes are ø4 (mm) or ø5/32" (inch) for the 10-SV1000/2000 series, and ø6 (mm) or ø1/4" (inch) for the 10-SV3000 series.

How to Order Manifold Assembly

Example (10-SS5V1)

Manifold
Power supply with
M12 connector

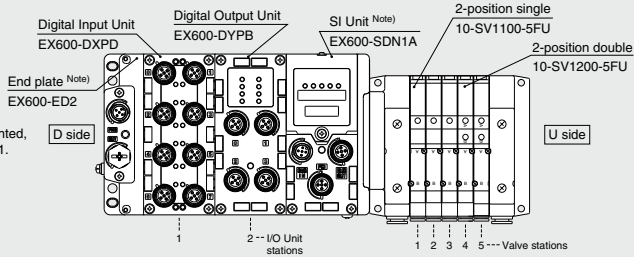

For the I/O Unit part number mounted, refer to the Best Pneumatics No. 1.

- Digital Input Unit
- Digital Output Unit
- Digital Input/Output Unit
- Analog Input Unit
- Analog Output Unit
- Analog Input/Output Unit

Serial transmission kit

- 10-SS5V1-W10S6Q2N2D-05B-C6 ... 1 set
- * 10-SV1100-5FU 3 sets
- * 10-SV1200-5FU 2 sets
- * EX600-DXPD 1 set
- * EX600-DYPB 1 set

- Manifold base part number
- Valve part number (Stations 1 to 3)
- Valve part number (Stations 4 to 5)
- I/O Unit part number (Station 1)
- I/O Unit part number (Station 2)

Enter in order starting from the first station on the D side.
For complex arrangements, specify them on the manifold specification sheet.

Enter in order starting from the first station on the D side.
For complex arrangements, specify them on the manifold specification sheet.

Note) Do not enter the SI Unit part number and the end plate part number together.

The asterisk denotes the symbol for assembly.
Prefix it to the part numbers of the solenoid valve, etc.

How to Order Valve

10-SV 1 1 00 - 5 FU (Note)

Series

1	10-SV1000
2	10-SV2000
3	10-SV3000

Actuation type

1	2-position single
2	2-position double
3	3-position closed center
4	3-position exhaust center
5	3-position pressure center
A	4-position dual 3-port valve (N.C./N.C.)
B	4-position dual 3-port valve (N.O./N.O.)
C	4-position dual 3-port valve (N.C./N.O.)

* 4-position dual 3-port valves are applicable to the 10-SV1000/2000 series only.

Pilot type

Nil	Internal pilot
R	External pilot

* External pilot specifications are not available for 4-position dual 3-port valves.

Back pressure check valve

Nil	None
K	Built-in

* The built-in back pressure check valve type is applicable to the 10-SV1000 series only.

* The product with back pressure check valve is not available for 3-position valves.

Note) Available with manifold block for station additions. Refer to the **WEB catalog**.

Made to Order

Nil	—
X90	Main valve fluororubber (Refer to page 272.)

Manual override

Nil: Non-locking push type
D: Push-turn locking slotted type

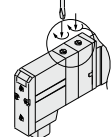
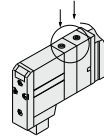

Light/surge voltage suppressor

U	With light/surge voltage suppressor
R	With surge voltage suppressor

Rated voltage

5	24 VDC
---	--------

Refer to the catalog of each series for details on manifold solenoid valve specifications, Common Precautions and Specific Product Precautions.

Dimensions: Series 10-SV1000

Power supply with M12 connector

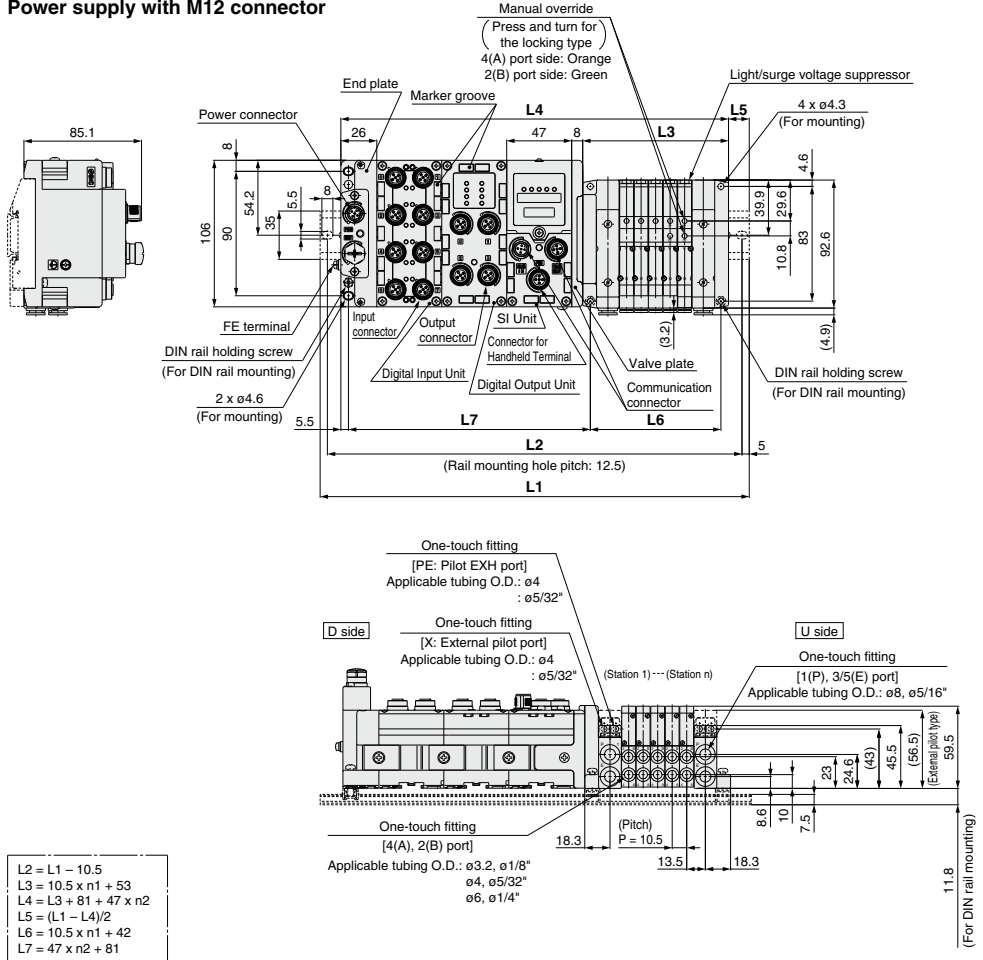

L1: DIN Rail Overall Length

I/O Unit stations (n2) \ Valve stations (n1)	2	3	4	5	6	7	8	9	10	11	12	13	14	15	16	17	18	19	20
0	185.5	198	210.5	210.5	223	235.5	248	260.5	273	273	285.5	298	310.5	323	335.5	348	348	360.5	373
1	235.5	248	248	260.5	273	285.5	298	310.5	310.5	323	335.5	348	360.5	373	373	385.5	398	410.5	423
2	273	285.5	298	310.5	323	335.5	335.5	348	360.5	373	385.5	398	410.5	410.5	423	435.5	448	460.5	473
3	323	335.5	348	360.5	373	373	385.5	398	410.5	423	435.5	435.5	448	460.5	473	485.5	498	498	510.5
4	373	385.5	398	398	410.5	423	435.5	448	460.5	473	473	485.5	498	510.5	523	535.5	548	548	560.5
5	423	435.5	435.5	448	460.5	473	485.5	498	498	510.5	523	535.5	548	560.5	560.5	573	585.5	598	610.5
6	460.5	473	485.5	498	510.5	523	535.5	535.5	548	560.5	573	585.5	598	598	610.5	623	635.5	648	660.5
7	510.5	523	535.5	548	560.5	560.5	573	585.5	598	610.5	623	623	635.5	648	660.5	673	685.5	698	698
8	560.5	573	585.5	598	598	610.5	623	635.5	648	660.5	660.5	673	685.5	698	710.5	723	723	735.5	748
9	610.5	623	623	635.5	648	660.5	673	685.5	685.5	698	710.5	723	735.5	748	760.5	760.5	773	785.5	798

Dimensions: Series 10-SV1000

Power supply with 7/8 inch connector

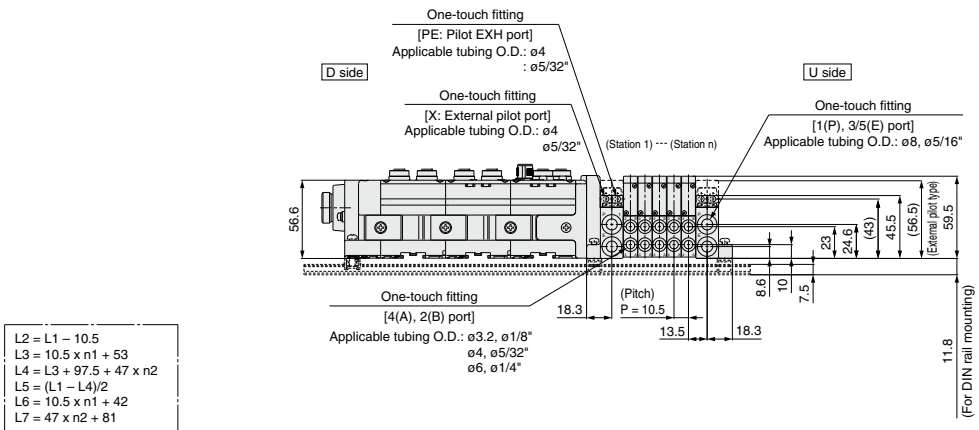
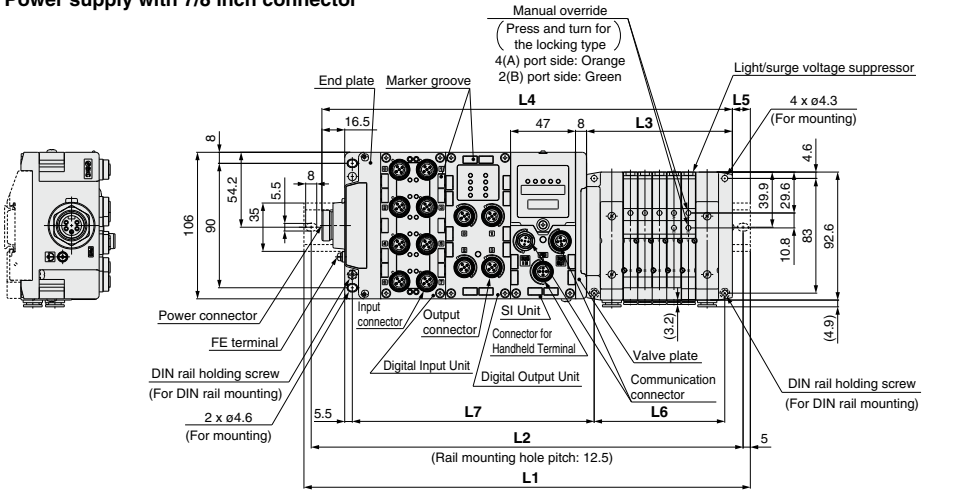

L1: DIN Rail Overall Length

I/O Unit stations (n2)	Valve stations (n1)	2	3	4	5	6	7	8	9	10	11	12	13	14	15	16	17	18	19	20		
0	198	210.5	223	235.5	248	248	260.5	273	285.5	298	310.5	323	335.5	348	360.5	373	385.5	398	410.5	423	435.5	
1	248	260.5	273	285.5	298	298	310.5	323	335.5	348	360.5	373	385.5	398	410.5	423	435.5	448	460.5	473	485.5	
2	298	310.5	310.5	323	335.5	348	360.5	373	373	385.5	398	410.5	423	435.5	448	460.5	473	485.5	498	510.5	523	535.5
3	348	348	360.5	373	385.5	398	410.5	410.5	423	435.5	448	460.5	473	473	485.5	498	510.5	523	535.5	548	560.5	573
4	385.5	398	410.5	423	435.5	448	460.5	473	485.5	498	510.5	523	535.5	548	560.5	573	585.5	598	610.5	623	635.5	648
5	435.5	448	460.5	473	473	485.5	498	510.5	523	535.5	548	560.5	573	585.5	598	610.5	623	635.5	648	660.5	673	685.5
6	485.5	498	498	510.5	523	535.5	548	560.5	573	573	585.5	598	610.5	623	635.5	648	660.5	673	685.5	698	710.5	723
7	535.5	535.5	548	560.5	573	585.5	598	610.5	623	635.5	648	660.5	673	685.5	698	710.5	723	735.5	748	760.5	773	785.5
8	573	585.5	598	610.5	623	635.5	648	660.5	673	685.5	698	710.5	723	735.5	748	760.5	773	785.5	798	810.5	823	835.5
9	623	635.5	648	660.5	673	685.5	698	710.5	723	735.5	748	760.5	773	785.5	798	810.5	823	835.5	848	860.5	873	885.5

Directional Control Valves
Air Cylinders
Rotary Actuators
Air Grippers
Air Preparation Equipment
Modular F. R.
Pressure Control Equipment
Fittings & Tubing
Flow Control Equipment
Pressure Switches/ Pressure Sensors

Dimensions: Series 10-SV2000

Power supply with M12 connector

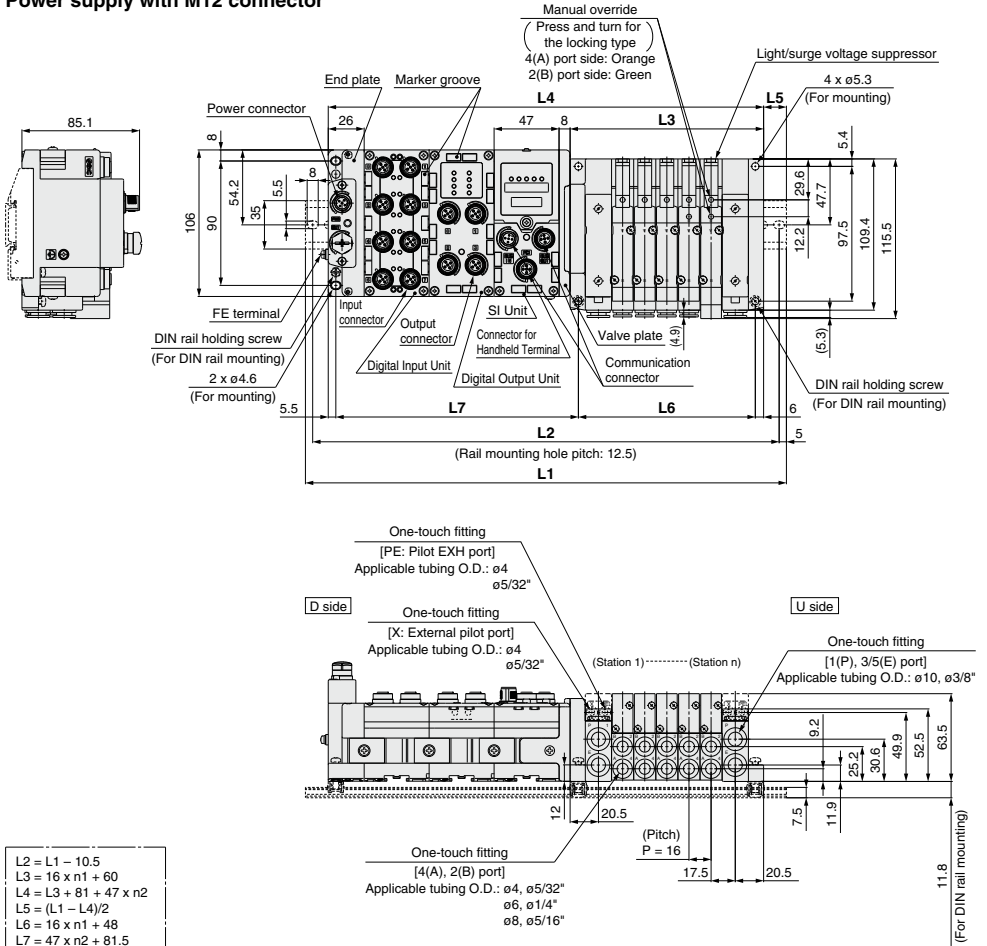

L1: DIN Rail Overall Length

I/O Unit stations (n2) \ Valve stations (n1)	2	3	4	5	6	7	8	9	10	11	12	13	14	15	16	17	18	19	20
0	198	223	235.5	248	260.5	285.5	298	310.5	335.5	348	360.5	373	398	410.5	423	448	460.5	473	485.5
1	248	260.5	285.5	298	310.5	335.5	348	360.5	373	398	410.5	423	435.5	460.5	473	485.5	510.5	523	535.5
2	298	310.5	323	348	360.5	373	398	410.5	423	435.5	460.5	473	485.5	510.5	523	535.5	548	573	585.5
3	348	360.5	373	385.5	410.5	423	435.5	460.5	473	485.5	498	523	535.5	548	573	585.5	598	610.5	635.5
4	385.5	410.5	423	435.5	460.5	473	485.5	498	523	535.5	548	560.5	585.5	598	610.5	635.5	648	660.5	673
5	435.5	448	473	485.5	498	523	535.5	548	560.5	585.5	598	610.5	635.5	648	660.5	673	698	710.5	723
6	485.5	498	510.5	535.5	548	560.5	585.5	598	610.5	623	648	660.5	673	698	710.5	723	735.5	760.5	773
7	535.5	548	560.5	585.5	598	610.5	623	648	660.5	673	685.5	710.5	723	735.5	760.5	773	785.5	798	823
8	573	598	610.5	623	648	660.5	673	685.5	710.5	723	735.5	760.5	773	785.5	798	823	835.5	848	860.5
9	623	635.5	660.5	673	685.5	710.5	723	735.5	748	773	785.5	798	823	835.5	848	860.5	885.5	898	910.5

Dimensions: Series 10-SV2000

Power supply with 7/8 inch connector

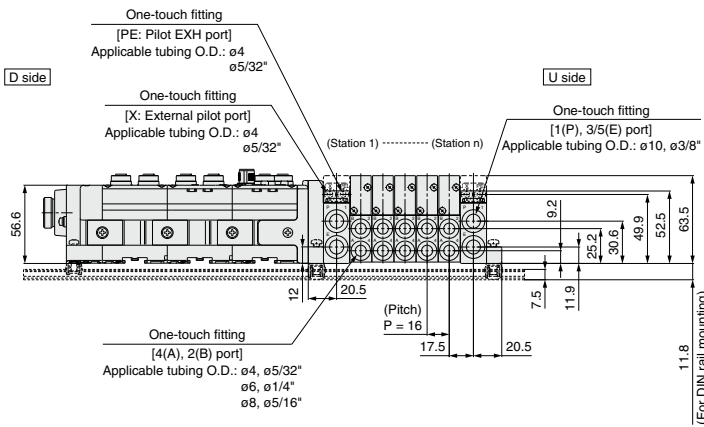
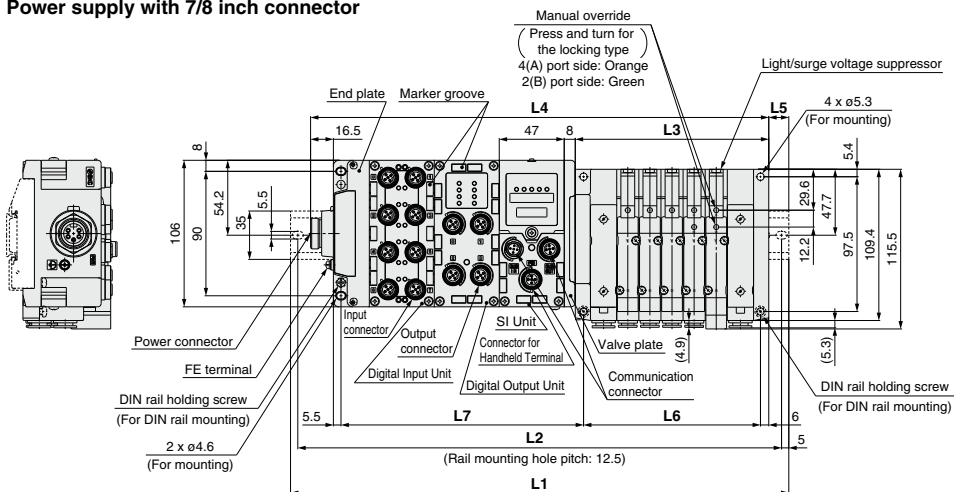

- L2 = L1 - 10.5
- L3 = 16 x n1 + 60
- L4 = L3 + 97.5 + 47 x n2
- L5 = (L1 - L4)/2
- L6 = 16 x n1 + 48
- L7 = 47 x n2 + 81.5

L1: DIN Rail Overall Length

I/O Unit stations (n2) \ Valve stations (n1)	2	3	4	5	6	7	8	9	10	11	12	13	14	15	16	17	18	19	20
0	223	235.5	248	273	285.5	298	310.5	335.5	348	360.5	373	398	410.5	423	448	460.5	473	485.5	510.5
1	260.5	285.5	298	310.5	335.5	348	360.5	373	398	410.5	423	448	460.5	473	485.5	510.5	523	535.5	548
2	310.5	323	348	360.5	373	398	410.5	423	435.5	460.5	473	485.5	510.5	523	535.5	548	573	585.5	598
3	360.5	373	398	410.5	423	435.5	460.5	473	485.5	498	523	535.5	548	573	585.5	598	610.5	635.5	648
4	410.5	423	435.5	460.5	473	485.5	498	523	535.5	548	573	585.5	598	610.5	635.5	648	660.5	673	698
5	448	473	485.5	498	523	535.5	548	560.5	585.5	598	610.5	635.5	648	660.5	673	698	710.5	723	748
6	498	523	535.5	548	560.5	585.5	598	610.5	623	648	660.5	673	698	710.5	723	735.5	760.5	773	785.5
7	548	560.5	585.5	598	610.5	623	648	660.5	673	698	710.5	723	735.5	760.5	773	785.5	798	823	835.5
8	598	610.5	623	648	660.5	673	685.5	710.5	723	735.5	760.5	773	785.5	798	823	835.5	848	873	885.5
9	648	660.5	673	685.5	710.5	723	735.5	748	773	785.5	798	823	835.5	848	860.5	885.5	898	910.5	935.5

Directional Control Valves
 Air Cylinders
 Rotary Actuators
 Air Grippers
 Air Preparation Equipment
 Modular F. R.
 Pressure Control Equipment
 Fittings & Tubing
 Flow Control Equipment
 Pressure Switches/ Pressure Sensors

Dimensions: Series 10-SV3000

Power supply with M12 connector

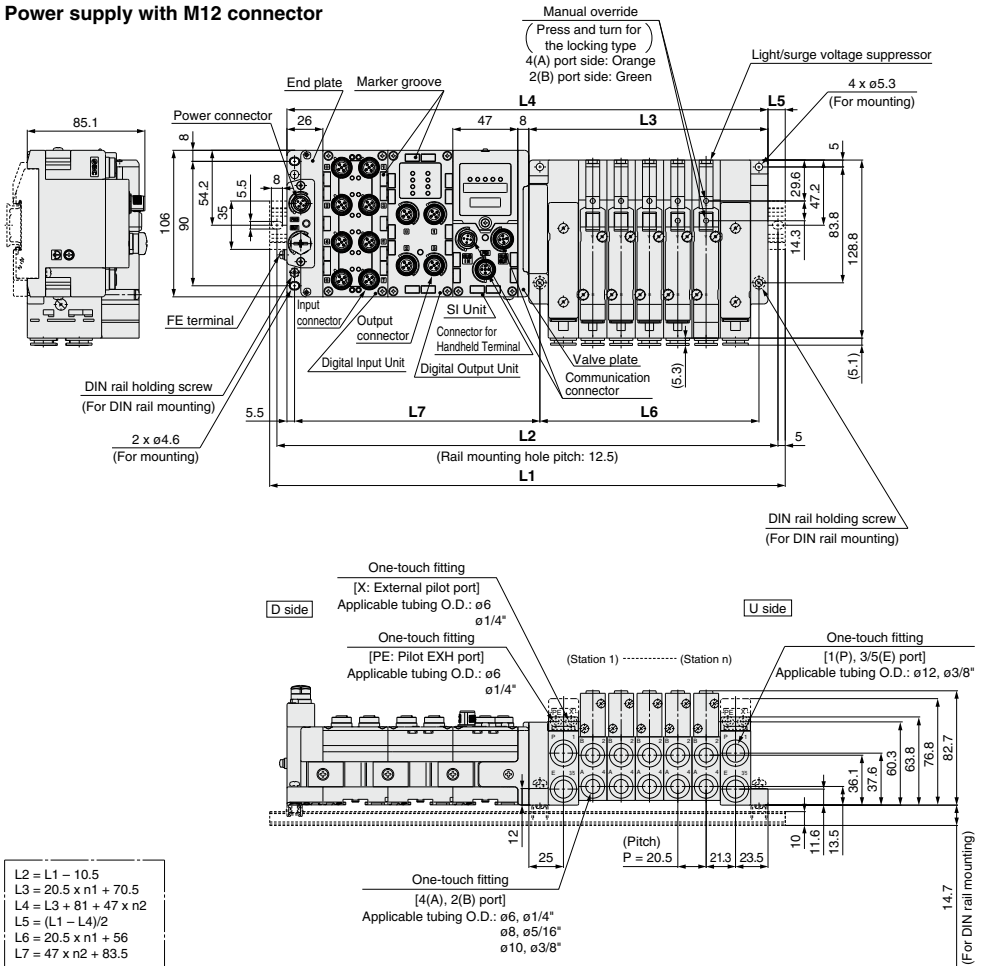

L1: DIN Rail Overall Length

I/O Unit stations (n2) \ Valve stations (n1)	2	3	4	5	6	7	8	9	10	11	12	13	14	15	16	17	18	19	20
0	223	248	260.5	285.5	298	323	348	360.5	385.5	410.5	423	448	473	485.5	510.5	535.5	548	573	585.5
1	273	285.5	310.5	335.5	348	373	398	410.5	435.5	448	473	498	510.5	535.5	560.5	573	598	623	635.5
2	310.5	335.5	360.5	373	398	423	435.5	460.5	485.5	498	523	535.5	560.5	585.5	598	623	648	660.5	685.5
3	360.5	385.5	398	423	448	460.5	485.5	510.5	523	548	573	585.5	610.5	635.5	648	673	685.5	710.5	735.5
4	410.5	435.5	448	473	498	510.5	535.5	548	573	598	610.5	635.5	660.5	673	698	723	735.5	760.5	773
5	460.5	473	498	523	535.5	560.5	585.5	598	623	635.5	660.5	685.5	698	723	748	760.5	785.5	810.5	823
6	498	523	548	560.5	585.5	610.5	623	648	673	685.5	710.5	735.5	748	773	785.5	810.5	835.5	848	873
7	548	573	598	610.5	635.5	648	673	698	710.5	735.5	760.5	773	798	823	835.5	860.5	873	898	923
8	598	623	635.5	660.5	685.5	698	723	735.5	760.5	785.5	798	823	848	860.5	885.5	910.5	923	948	973
9	648	660.5	685.5	710.5	723	748	773	785.5	810.5	835.5	848	873	885.5	910.5	935.5	948	973	—	—

Dimensions: Series 10-SV3000

Power supply with 7/8 inch connector

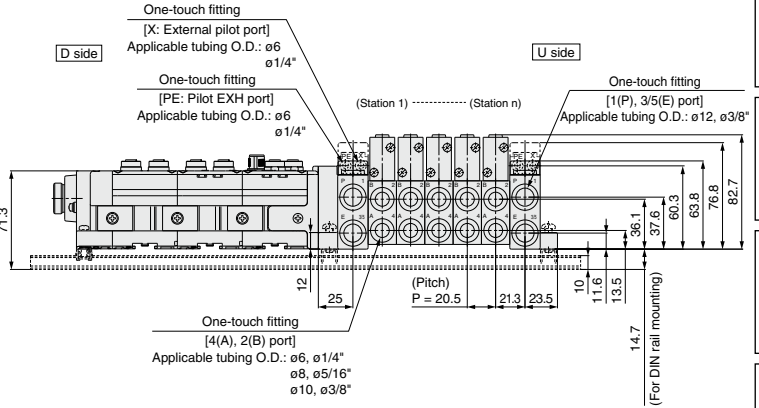
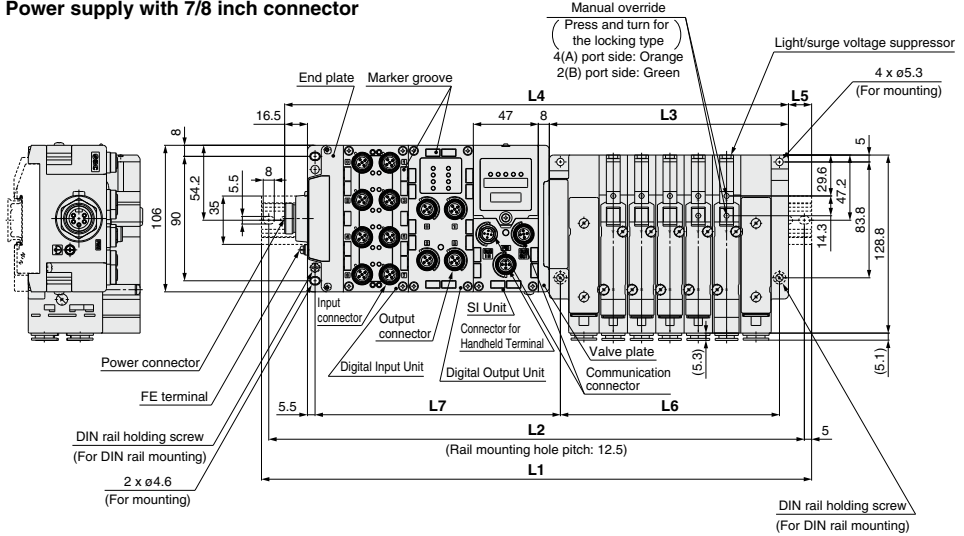

L2 =	L1 - 10.5
L3 =	20.5 x n1 + 70.5
L4 =	L3 + 97.5 + 47 x n2
L5 =	(L1 - L4)/2
L6 =	20.5 x n1 + 56
L7 =	47 x n2 + 83.5

L1: DIN Rail Overall Length

I/O Unit stations (n2) \ Valve stations (n1)	2	3	4	5	6	7	8	9	10	11	12	13	14	15	16	17	18	19	20
0	235.5	260.5	285.5	298	323	335.5	360.5	385.5	398	423	448	460.5	485.5	510.5	523	548	560.5	585.5	610.5
1	285.5	310.5	323	348	373	385.5	410.5	423	448	473	485.5	510.5	535.5	548	573	598	610.5	635.5	660.5
2	335.5	348	373	398	410.5	435.5	460.5	473	498	523	535.5	560.5	573	598	623	635.5	660.5	685.5	698
3	385.5	398	423	435.5	460.5	485.5	498	523	548	560.5	585.5	610.5	623	648	660.5	685.5	710.5	723	748
4	423	448	473	485.5	510.5	523	548	573	585.5	610.5	635.5	648	673	698	710.5	735.5	760.5	773	798
5	473	498	510.5	535.5	560.5	573	598	623	635.5	660.5	673	698	723	735.5	760.5	785.5	798	823	848
6	523	535.5	560.5	585.5	598	623	648	660.5	685.5	710.5	723	748	760.5	785.5	810.5	823	848	873	885.5
7	573	585.5	610.5	623	648	673	685.5	710.5	735.5	748	773	798	810.5	835.5	860.5	873	898	910.5	935.5
8	610.5	635.5	660.5	673	698	723	735.5	760.5	773	798	823	835.5	860.5	885.5	898	923	948	960.5	985.5
9	660.5	685.5	698	723	748	760.5	785.5	810.5	823	848	860.5	885.5	910.5	923	948	973	985.5	—	—

Directional Control Valves
Air Cylinders
Rotary Actuators
Air Grippers
Air Preparation Equipment
Modular F. R.
Pressure Control Equipment
Fittings & Tubing
Flow Control Equipment
Pressure Switches/Pressure Sensors

Dedicated Output Serial Wiring

Series EX120

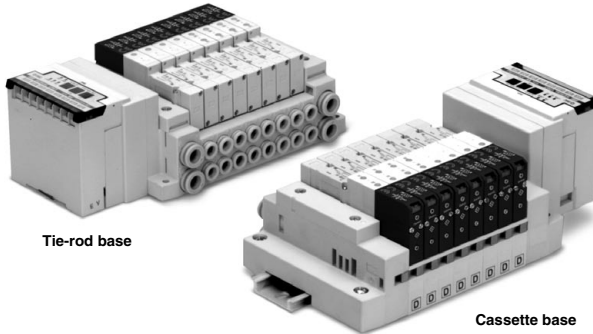

Tie-rod base

Cassette base

Applicable series	Cassette base manifold 10-SV1000/10-SV2000
	Tie-rod base manifold 10-SV1000/10-SV2000/10-SV3000/10-SV4000
· Number of outputs: 16	

Directional
Control Valves

Air Cylinders

Rotary Actuators

Air Grippers

Air Preparation
Equipment

Modular F. R.

Pressure Control
Equipment

Fittings & Tubing

Flow Control
Equipment

Pressure Switches/
Pressure Sensors

Series 10-SV

EX120 Dedicated Output Serial Wiring

How to Order

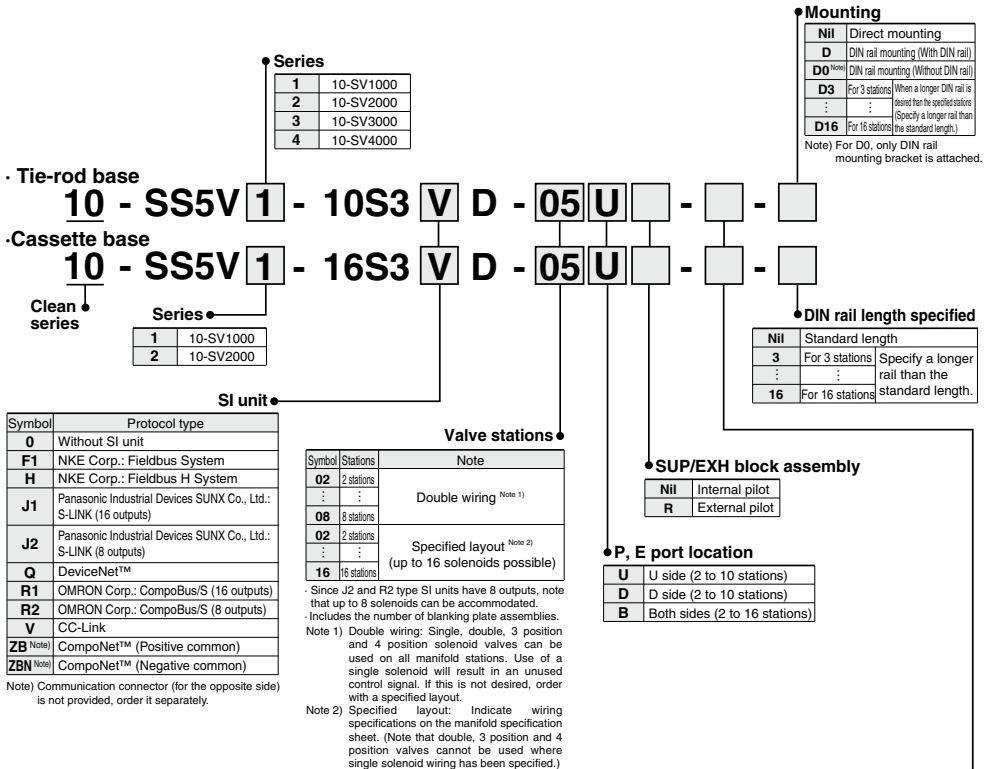

A, B port size (Metric)				A, B port size (Inch)			
Symbol	A, B port	P, E port	Applicable series	Symbol	A, B port	P, E port	Applicable series
C3	ø3.2 One-touch fitting	ø8 One-touch fitting	10-SV1000	N1	ø1/8" One-touch fitting	ø5/16" One-touch fitting	10-SV1000
C4	ø4 One-touch fitting						
C6	ø6 One-touch fitting						
C4	ø4 One-touch fitting	ø10 One-touch fitting	10-SV2000	N3	ø5/32" One-touch fitting	ø3/8" One-touch fitting	10-SV2000
C6	ø6 One-touch fitting						
C8	ø8 One-touch fitting						
C6	ø6 One-touch fitting	ø12 One-touch fitting	10-SV3000	N7	ø1/4" One-touch fitting	ø3/8" One-touch fitting	10-SV3000
C8	ø8 One-touch fitting						
C10	ø10 One-touch fitting						
C8	ø8 One-touch fitting	ø12 One-touch fitting	10-SV4000	N9	ø5/16" One-touch fitting	ø3/8" One-touch fitting	10-SV3000
C10	ø10 One-touch fitting						
C12	ø12 One-touch fitting						
02	Rc 1/4	Rc 3/8	10-SV4000	N9	ø5/16" One-touch fitting	ø3/8" One-touch fitting	10-SV4000
03	Rc 3/8						
02F	G 1/4						
03F	G 3/8	G 3/8		N11	ø3/8" One-touch fitting	NPTF 3/8	10-SV4000
M	Mixed			02N	NPT 1/4		
				03N	NPT 3/8		
				02T	NPTF 1/4		
				03T	NPTF 3/8		
				M	Mixed		

* For mixed specifications (M), indicate separately on the manifold specification sheet.
 * External pilot type (R) X, PE port sizes are ø4 (metric), ø5/32" (inch) for the 10-SV1000/2000 series and ø6 (metric), ø1/4" (inch) for the 10-SV3000/4000 series.

How to Order Valve Manifold Assembly

Ordering example (10-SV1000)

Manifold

10-SS5V1-16S3VD-06B-C6 (1 set)

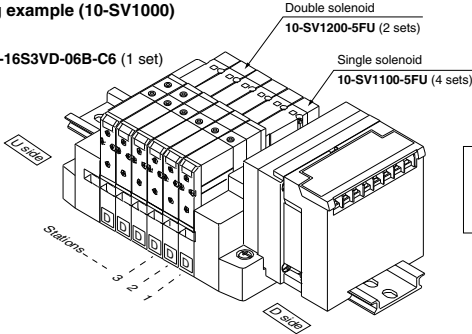

10-SS5V1-16S3VD-06B-C6.....1 set (Manifold part no.)
 * 10-SV1100-5FU.....4 sets (Single solenoid part no.)
 * 10-SV1200-5FU.....2 sets (Double solenoid part no.)

How to Order Solenoid Valve

10 - SV 1 1 0 0 - 5 F - - - (Note)

Clean series

Series

1	10-SV1000
2	10-SV2000
3	10-SV3000
4	10-SV4000

Actuation type

1	2 position single solenoid
2	2 position double solenoid
3	3 position closed center
4	3 position exhaust center
5	3 position pressure center
A	4 position dual 3 port valve: N.C./N.C.
B	4 position dual 3 port valve: N.O./N.O.
C	4 position dual 3 port valve: N.C./N.O.

* 4 position dual 3 port valves are applicable to the 10-SV1000 and 10-SV2000 series only.

Pilot type

Nil	Internal pilot
R	External pilot

* External pilot specifications are not available for 4 position dual 3 port valves.

Back pressure check valve

Nil	None
K	Built-in

* The built-in back pressure check valve type is applicable to the 10-SV1000 series only.
 * The product with back pressure check valve is not available for 3 position solenoid valves.

Rated voltage

5	24 VDC
---	--------

Manual override

Nil:	Non-locking push type
D:	Push-turn locking slotted type

Light/surge voltage suppressor

U	With light/surge voltage suppressor
R	With surge voltage suppressor

Made to Order

Nil	-
X90	Main valve fluororubber (Refer to page 272.)

Note) Available with manifold block for station additions. Refer to the **WEB catalog**.

Note) Refer to the Specific Product Precautions 2 on page 274.

Directional Control Valves

Air Cylinders

Rotary Actuators

Air Grippers

Air Preparation Equipment

Modular F. R.

Pressure Control Equipment

Fittings & Tubing

Flow Control Equipment

Pressure Switches/ Pressure Sensors

Dimensions: Series 10-SV1000 for EX120 Dedicated Output Serial Wiring

- **Cassette base manifold: 10-SS5V1-16S3□D- Stations** U
D (R)
B C3, N1
C4, N3
C6, N7

•When P, E port outlets are indicated on the U side or D side, the P, E ports on the opposite side are plugged.
 •External pilot port positions are the same as P, E port outlet positions.

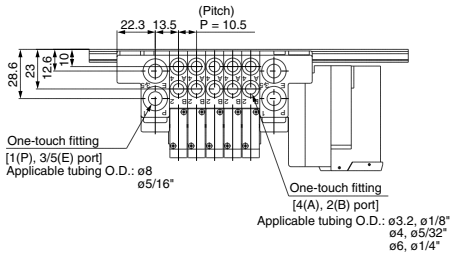

With external pilot specifications

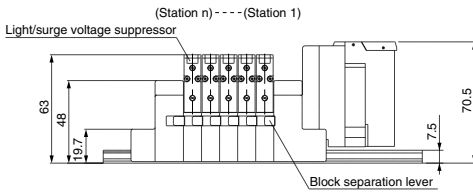
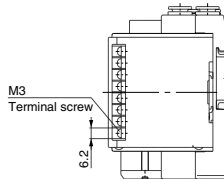
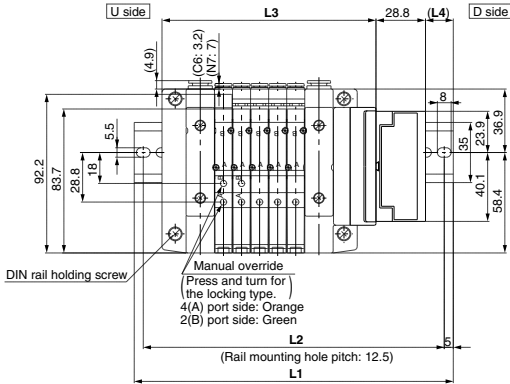
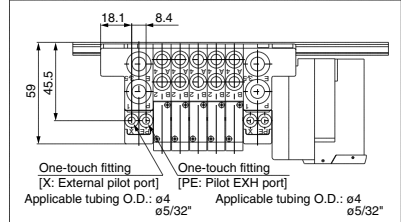

With option

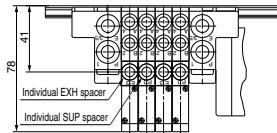

L Dimension

L ⁿ	2	3	4	5	6	7	8	9	10	11	12	13	14	15	16
L1	148	160.5	173	185.5	198	198	210.5	223	235.5	248	260.5	260.5	273	285.5	298
L2	137.5	150	162.5	175	187.5	187.5	200	212.5	225	237.5	250	250	262.5	275	287.5
L3	92.9	103.4	113.9	124.4	134.9	145.4	155.9	166.4	176.9	187.4	197.9	208.4	218.9	229.4	239.9
L4	13	14	15	16	17	12	13	14	15	16	17	11.5	12.5	13.5	14.5

Dimensions: Series 10-SV2000 for EX120 Dedicated Output Serial Wiring

- **Cassette base manifold: 10-SS5V2-16S3□D- Stations** $\begin{matrix} U \\ D \\ B \end{matrix}$ (R) $\begin{matrix} C4, N3 \\ C6, N7 \\ C8, N9 \end{matrix}$

•When P, E port outlets are indicated on the U side or D side, the P, E ports on the opposite side are plugged.
 •External pilot port positions are the same as P, E port outlet positions.

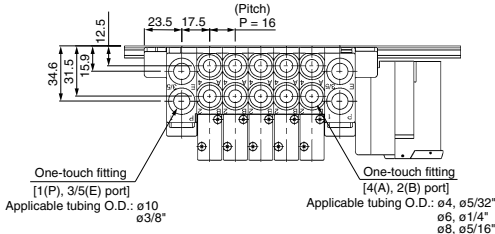

With external pilot specifications

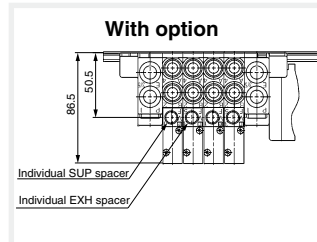
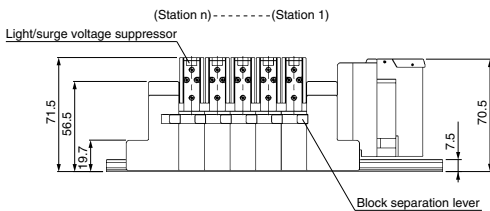
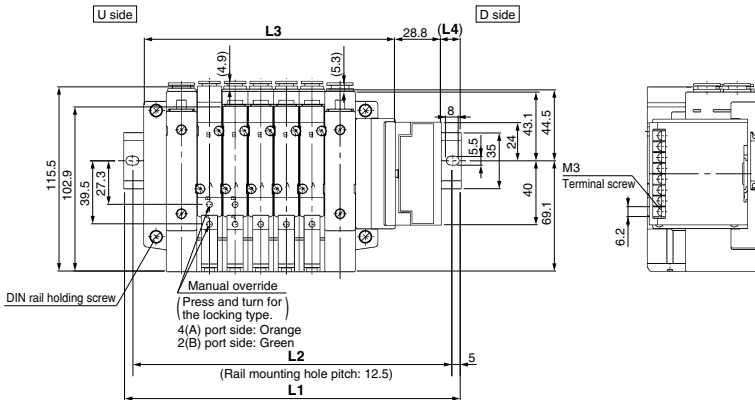
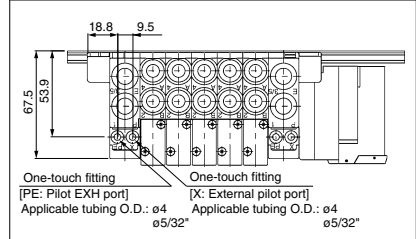

L Dimension

L	n	2	3	4	5	6	7	8	9	10	11	12	13	14	15	16
L1		173	185.5	198	210.5	235.5	248	260.5	273	298	310.5	323	348	360.5	373	385.5
L2		162.5	175	187.5	200	225	237.5	250	262.5	287.5	300	312.5	337.5	350	362.5	375
L3		108.9	124.9	140.9	156.9	172.9	188.9	204.9	220.9	236.9	252.9	268.9	284.9	300.9	316.9	332.9
L4		17.5	16	14	12.5	17	15	13.5	11.5	16	14.5	12.5	17	15.5	13.5	12

n: Stations

Directional Control Valves
 Air Cylinders
 Rotary Actuators
 Air Grippers
 Air Preparation Equipment
 Modular F. R.
 Pressure Control Equipment
 Fittings & Tubing
 Flow Control Equipment
 Pressure Switches/ Pressure Sensors

Dimensions: Series 10-SV1000 for EX120 Dedicated Output Serial Wiring

- Tie-rod base manifold: 10-SS5V1-10S3□D-(Stations) $\frac{U}{B}$ (R) - $\begin{matrix} C3, N1 \\ C4, N3 \\ C6, N7 \end{matrix}$ (D)

•When P, E port outlets are indicated on the U side or D side, the P, E ports on the opposite side are plugged.
 •External pilot port positions are the same as P, E port outlet positions.

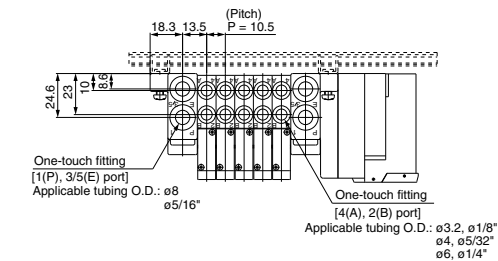

With external pilot specifications

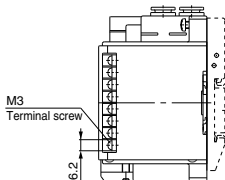
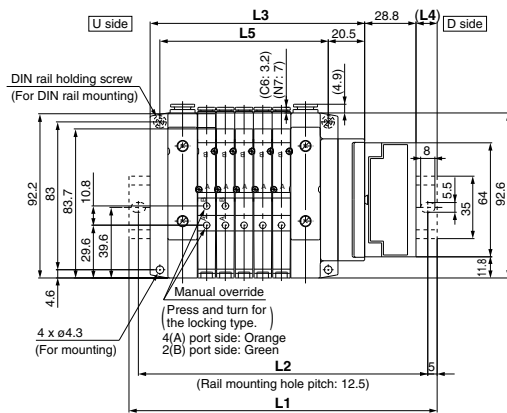
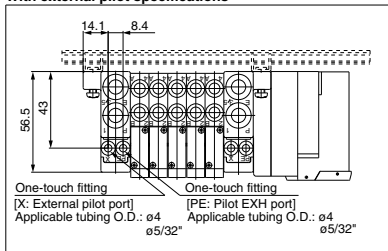

(Station n) --- (Station 1)

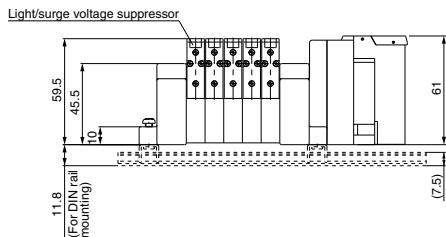

With option

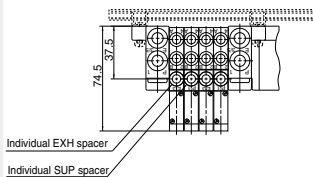

L Dimension

n: Stations

L	2	3	4	5	6	7	8	9	10	11	12	13	14	15	16
L1	148	160.5	173	173	185.5	198	210.5	223	235.5	235.5	248	260.5	273	285.5	298
L2	137.5	150	162.5	162.5	175	187.5	200	212.5	225	225	237.5	250	262.5	275	287.5
L3	89	99.5	110	120.5	131	141.5	152	162.5	173	183.5	194	204.5	215	225.5	236
L4	15	16	17	12	13	14	15	16	17	11.5	12.5	13.5	14.5	15.5	16.5
L5	63	73.5	84	94.5	105	115.5	126	136.5	147	157.5	168	178.5	189	199.5	210

Dimensions: Series 10-SV2000 for EX120 Dedicated Output Serial Wiring

• Tie-rod base manifold: 10-SS5V2-10S3□D-**Stations** $\begin{matrix} \text{U} \\ \text{D} \end{matrix}$ (R) $\begin{matrix} \text{C4, N3} \\ \text{C6, N7} \\ \text{C8, N9} \end{matrix}$ (-D)

- When P, E port outlets are indicated on the U side or D side, the P, E ports on the opposite side are plugged.
- External pilot port positions are the same as P, E port outlet positions.

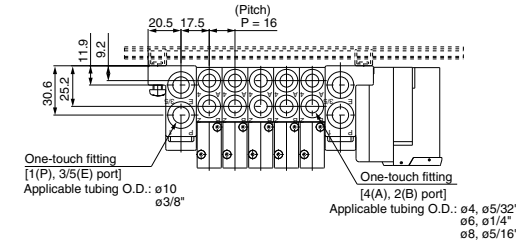

With external pilot specifications

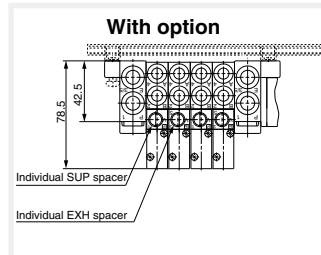
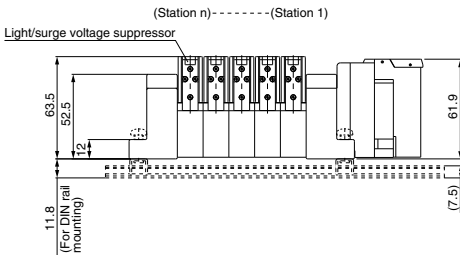
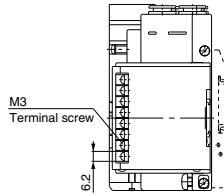
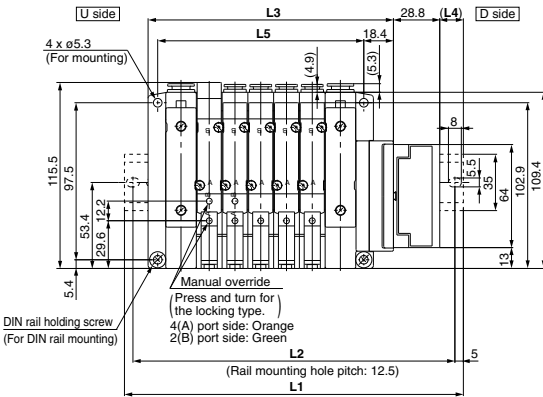
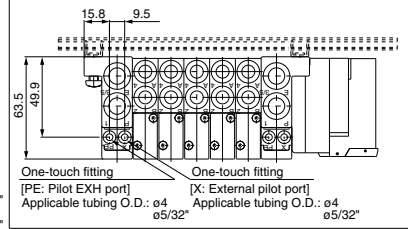

L Dimension		n: Stations															
L	n	2	3	4	5	6	7	8	9	10	11	12	13	14	15	16	
L1		160.5	173	198	210.5	223	248	260.5	273	285.5	310.5	323	335.5	360.5	373	385.5	
L2		150	162.5	187.5	200	212.5	237.5	250	262.5	275	300	312.5	325	350	362.5	375	
L3		104.4	120.4	136.4	152.4	168.4	184.4	200.4	216.4	232.4	248.4	264.4	280.4	296.4	312.4	328.4	
L4		13.5	12	16.5	14.5	13	17.5	15.5	14	12	16.5	15	13	17.5	16	14	
L5		80	96	112	128	144	160	176	192	208	224	240	256	272	288	304	

Directional Control Valves

Air Cylinders

Rotary Actuators

Air Grippers

Air Preparation Equipment

Modular F. R.

Pressure Control Equipment

Fittings & Tubing

Flow Control Equipment

Pressure Switches/ Pressure Sensors

Dimensions: Series 10-SV3000 for EX120 Dedicated Output Serial Wiring

- Tie-rod base manifold: 10-SS5V3-10S3□D-**Stations** $\begin{matrix} \text{U} \\ \text{D} \end{matrix}$ (R) $\begin{matrix} \text{C6, N7} \\ \text{C8, N9} \\ \text{C10, N11} \end{matrix}$ (-D)

•When P, E port outlets are indicated on the U side or D side, the P, E ports on the opposite side are plugged.
 •External pilot port positions are the same as P, E port outlet positions.

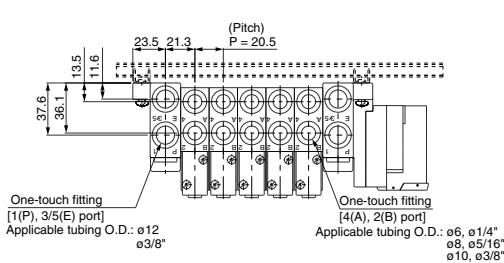

With external pilot specifications

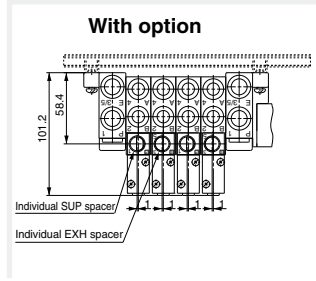
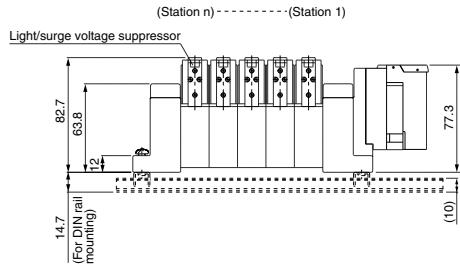
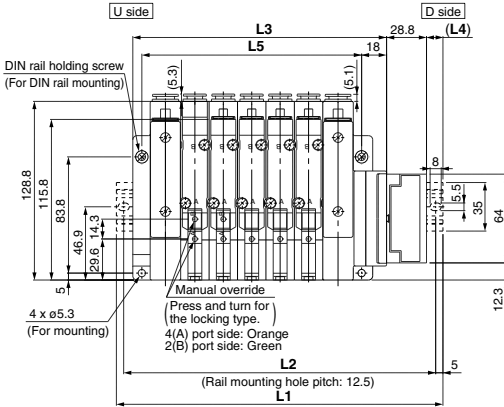
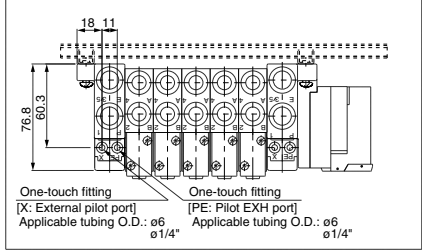

L Dimension

n	n: Stations															
	2	3	4	5	6	7	8	9	10	11	12	13	14	15	16	
L1	185.5	198	223	235.5	260.5	285.5	298	323	348	360.5	385.5	410.5	423	448	460.5	
L2	175	187.5	212.5	225	250	275	287.5	312.5	337.5	350	375	400	412.5	437.5	450	
L3	121.5	142	162.5	183	203.5	224	244.5	265	285.5	306	326.5	347	367.5	388	408.5	
L4	17.5	13.5	16	12	14	16.5	12.5	14.5	17	13	15	17.5	13.5	15.5	11.5	
L5	97	117.5	138	158.5	179	199.5	220	240.5	261	281.5	302	322.5	343	363.5	384	

Dimensions: Series 10-SV4000 for EX120 Dedicated Output Serial Wiring

- Tie-rod base manifold: 10-SS5V4-10S3□D-**Stations** $\begin{matrix} U \\ D \end{matrix}$ (R) $\begin{matrix} \square \\ \square \end{matrix}$ $\begin{matrix} C8, \\ C10, \\ C12 \end{matrix}$ $\begin{matrix} N9 \\ N11 \end{matrix}$ (-D)

•When P, E port outlets are indicated on the U side or D side, the P, E ports on the opposite side are plugged.
 •External pilot port positions are the same as P, E port outlet positions.

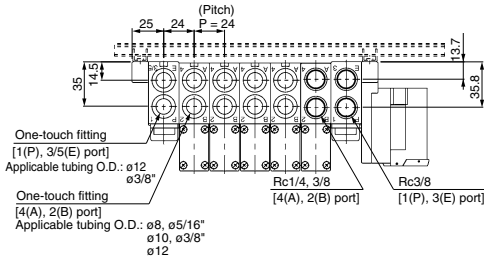

With external pilot specifications

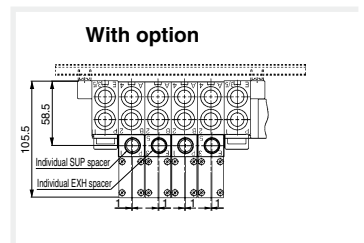
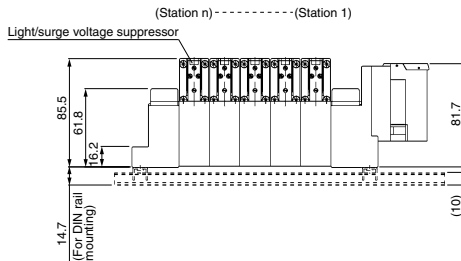
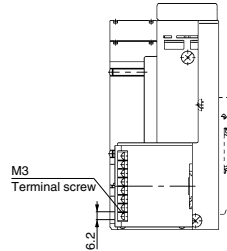
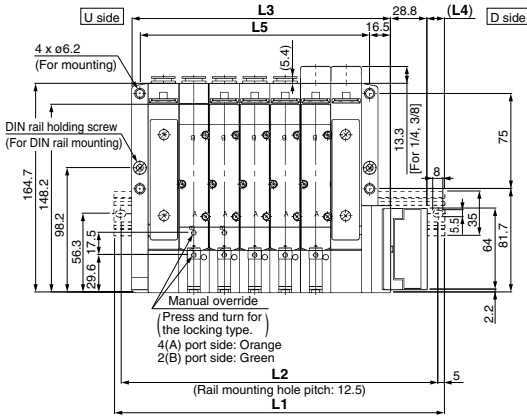
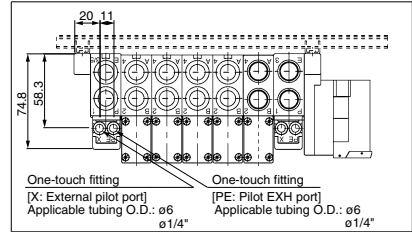

L Dimension

n	2	3	4	5	6	7	8	9	10	11	12	13	14	15	16
L1	185.5	210.5	235.5	260.5	285.5	310.5	335.5	360.5	385.5	410.5	435.5	448	473	498	523
L2	175	200	225	250	275	300	325	350	375	400	425	437.5	462.5	487.5	512.5
L3	132	156	180	204	228	252	276	300	324	348	372	396	420	444	468
L4	12.5	13	13.5	14	14.5	15	15.5	16	16.5	17	17.5	11.5	12	12.5	13
L5	109	133	157	181	205	229	253	277	301	325	349	373	397	421	445

n: Stations

Directional Control Valves
 Air Cylinders
 Rotary Actuators
 Air Grippers
 Air Preparation Equipment
 Modular F. R.
 Pressure Control Equipment
 Fittings & Tubing
 Flow Control Equipment
 Pressure Switches/ Pressure Sensors

Integrated Type (For Output) Serial Transmission System

Series **EX260** IP67 compliant (Some products are IP40)

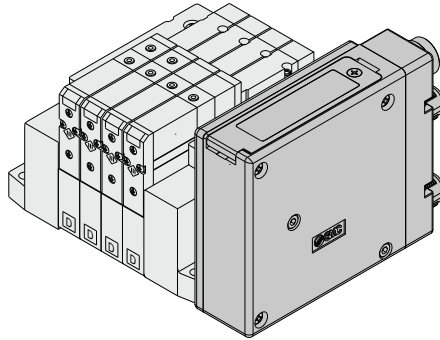

Tie-rod base

Applicable series	Tie-rod base manifold 10-SV1000/10-SV2000/10-SV3000
	· Number of outputs: 16, 32

Directional
Control Valves

Air Cylinders

Rotary Actuators

Air Grippers

Air Preparation
Equipment

Modular F. R.

Pressure Control
Equipment

Fittings & Tubing

Flow Control
Equipment

Pressure Switches/
Pressure Sensors



How to Order Manifold

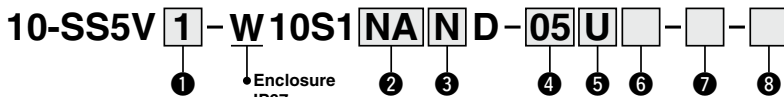

Enclosure IP67
 * Refer to Note 1) of the ② SI unit specifications.

① Series

1	10-SV1000
2	10-SV2000
3	10-SV3000

② SI unit specifications

Symbol	Protocol	Number of outputs	Communication connector
0	Without SI unit		
QA	DeviceNet™	32	M12
QB		16	
NA		32	
NB		16	
NC	PROFIBUS DP	32	D-sub Note 1)
ND		16	
VA	CC-Link	32	M12
VB		16	
DA	EtherCAT	32	M12
DB		16	
FA	PROFINET	32	M12
FB		16	
EA	EtherNet/IP™	32	M12
EB		16	

• DIN rail cannot be selected for the product without SI unit.

Note 1) IP40 for the D-sub applicable communication connector specifications. (The manifold part number is "10-SS5V □-10S1NC/ND□D".)

Note 2) For SI unit part number, refer to the Best Pneumatics No. 1.

③ SI unit output polarity

Nii	Positive common
N	Negative common

Note) The symbol is nil for no SI unit.

⑦ A, B port size (Metric)

Symbol	A, B port	P, E port	Applicable series
C3	ø3.2 One-touch fitting	ø8 One-touch fitting	10-SV1000
C4	ø4 One-touch fitting		
C6	ø6 One-touch fitting		
C4	ø4 One-touch fitting		
C6	ø6 One-touch fitting	ø10 One-touch fitting	10-SV2000
C8	ø8 One-touch fitting		
C6	ø6 One-touch fitting		
C8	ø8 One-touch fitting		
C10	ø10 One-touch fitting	ø12 One-touch fitting	10-SV3000
M	Mixed		

* For mixed specifications (M), indicate separately on the manifold specification sheet.

* External pilot type (R) X, PE port sizes are ø4 (mm) or ø5/32" (inch) for the 10-SV1000/2000 series, and ø6 (mm) or ø1/4" (inch) for the 10-SV3000 series.

④ Valve stations

For 32-output SI unit

Symbol	Stations	Note
02	2 stations	Double wiring Note 1)
⋮	⋮	
16	16 stations	
02	2 stations	Specified layout Note 2) (Available up to 32 solenoids)
⋮	⋮	
20	20 stations	

For 16-output SI unit

Symbol	Stations	Note
02	2 stations	Double wiring Note 1)
⋮	⋮	
08	8 stations	
02	2 stations	Specified layout Note 2) (Available up to 16 solenoids)
⋮	⋮	
16	16 stations	

Note 1) Double wiring: Single, double, 3-position and 4-position solenoid valves can be used on all manifold stations. Use of a single solenoid will result in an unused control signal. If this is not desired, order with a specified layout.

Note 2) Specified layout. Indicate the wiring specifications on the manifold specification sheet.

(Note that double, 3-position and 4-position valves cannot be used where single solenoid wiring has been specified.)

Note 3) Includes the number of blanking plate assemblies.

⑤ P, E port location

U	U side (2 to 10 stations)
D	D side (2 to 10 stations)
B	Both sides (2 to 20 stations)

⑥ SUP/EXH block assembly

Nii	Internal pilot
R	External pilot

⑧ Mounting

Nii	Direct mounting
D	DIN rail mounting (With DIN rail)
D0	DIN rail mounting (Without DIN rail)
D3	For 3 stations When a longer DIN rail is desired than the specified stations.
⋮	⋮ (Specify a longer rail than the standard length.)
D20	For 20 stations

* If the DIN rail must be mounted without SI unit, select "D0" and order the DIN rail separately. Refer to L3 of the dimensions for the DIN rail length. For the DIN rail part number, refer to the **WEB catalog** or SV series catalog (CAT.ES11-81).

A, B port size (Inch)

Symbol	A, B port	P, E port	Applicable series
N1	ø1/8" One-touch fitting	ø5/16" One-touch fitting	10-SV1000
N3	ø5/32" One-touch fitting		
N7	ø1/4" One-touch fitting		
N3	ø5/32" One-touch fitting	ø3/8" One-touch fitting	10-SV2000
N7	ø1/4" One-touch fitting		
N9	ø5/16" One-touch fitting		
N7	ø1/4" One-touch fitting		
N9	ø5/16" One-touch fitting	ø3/8" One-touch fitting	10-SV3000
N11	ø3/8" One-touch fitting		
M	Mixed		

How to Order Manifold Assembly

Example (10-SV1000)

Manifold
10-SS5V1-W10S1NAND-04B-C6 (1 set)

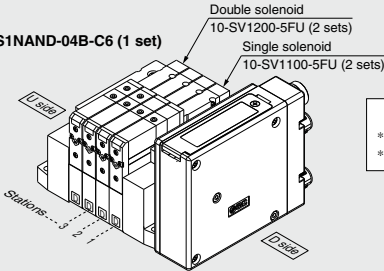

10-SS5V1-W10S1NAND-04B-C6.....1 set (Manifold part no.)
*10-SV1100-5FU.....2 sets (Single solenoid part no.)
*10-SV1200-5FU.....2 sets (Double solenoid part no.)

How to Order Valve

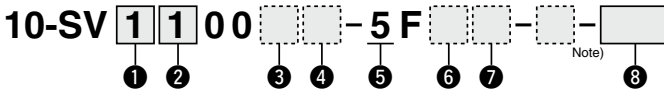

1 Series

1	10-SV1000
2	10-SV2000
3	10-SV3000

2 Actuation type

1	2-position single
2	2-position double
3	3-position closed center
4	3-position exhaust center
5	3-position pressure center
A	4-position dual 3-port valve: N.C./N.C.
B	4-position dual 3-port valve: N.O./N.O.
C	4-position dual 3-port valve: N.C./N.O.

* 4-position dual 3-port valves are applicable to the 10-SV1000/2000 series only.

3 Pilot type

NII	Internal pilot
R	External pilot

* External pilot specifications are not available for 4-position dual 3-port valves.

4 Back pressure check valve

NII	None
K	Built-in

* The built-in back pressure check valve type is applicable to the 10-SV1000 series only.
* The product with back pressure check valve is not available for 3-position valves.

Note) Refer to the Specific Product Precautions 2 in the Best Pneumatics No. 1.

5 Rated voltage

5	24 VDC
---	--------

6 Light/surge voltage suppressor

U	With light/surge voltage suppressor
R	With surge voltage suppressor

7 Manual override

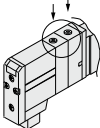
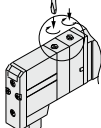
<p>NII: Non-locking push type</p> 	<p>D: Push-turn locking slotted type</p> 
-----------------------------------------------------------------------------------------------------------------------	------------------------------------------------------------------------------------------------------------------------------

Note) Available with manifold block for station additions. Refer to the **WEB catalog**.

8 Made to Order

NII	—
X90	Main valve fluororubber (Refer to page 272.)

Refer to the SMC website or the SV series in the Best Pneumatics No. 1 for details on solenoid valve specifications, Common Precautions and Specific Product Precautions.

Directional Control Valves
 Air Cylinders
 Rotary Actuators
 Air Grippers
 Air Preparation Equipment
 Modular F. R.
 Pressure Control Equipment
 Fittings & Tubing
 Flow Control Equipment
 Pressure Switches/Pressure Sensors

Dimensions: Series 10-SV1000 for EX260 Integrated-type (For Output) Serial Transmission System

● Tie-rod base manifold: 10-SS5V1-W10S1 □□D- Stations $\frac{U}{D}$ (R)- C3, N1
C4, N3 C6, N7 (-D)

- When P, E port outlets are indicated on the U side or D side, the P, E ports on the opposite side are plugged.
- External pilot port positions are the same as P, E port outlet positions.

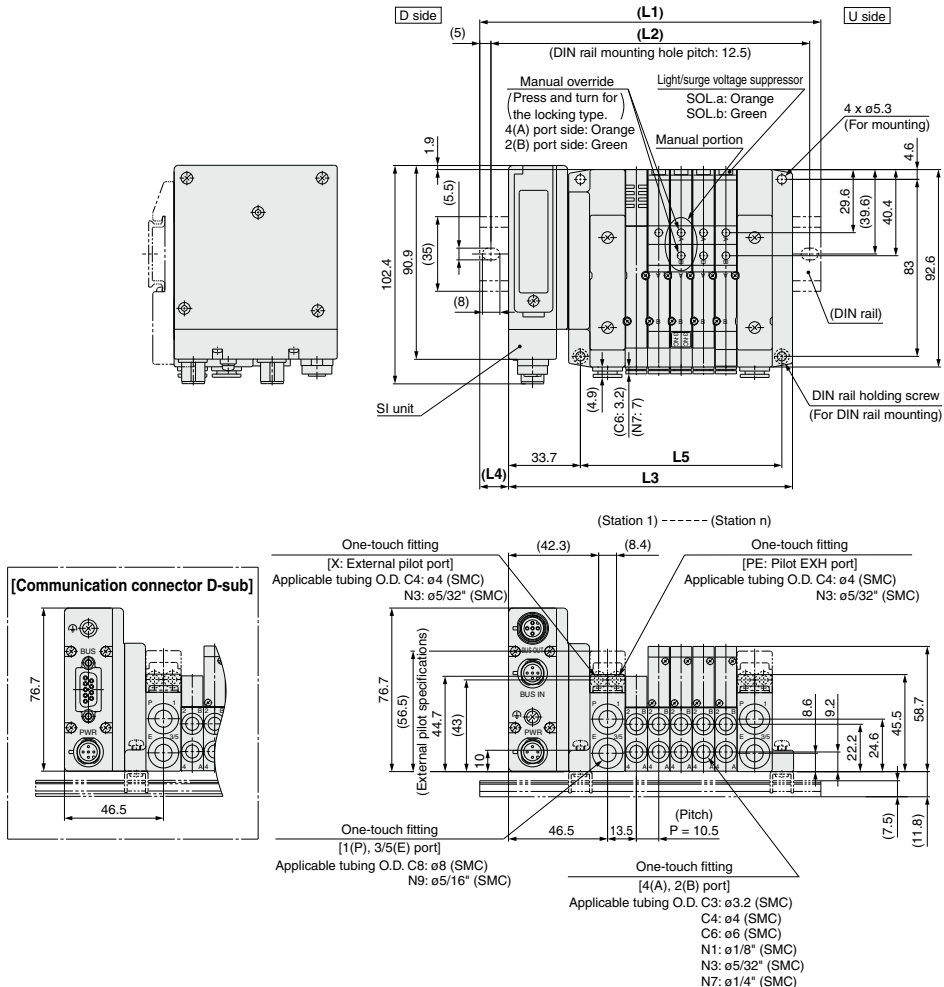

L: DIN Rail Overall Length

L	n: Stations																			
	2	3	4	5	6	7	8	9	10	11	12	13	14	15	16	17	18	19	20	
L1	135.5	148	148	160.5	173	185.5	198	210.5	210.5	223	235.5	248	260.5	273	273	285.5	298	310.5	323	
L2	125	137.5	137.5	150	162.5	175	187.5	200	200	212.5	225	237.5	250	262.5	262.5	275	287.5	300	312.5	
L3	102.2	112.7	123.2	133.7	144.2	154.7	165.2	175.7	186.2	196.7	207.2	217.7	228.2	238.7	249.2	259.7	270.2	280.7	291.2	
L4	16.5	17.5	12.5	13.5	14.5	15.5	16.5	17.5	12	13	14	15	16	17	12	13	14	15	16	
L5	63	73.5	84	94.5	105	115.5	126	136.5	147	157.5	168	178.5	189	199.5	210	220.5	231	241.5	252	

Dimensions: Series 10-SV2000 for EX260 Integrated-type (For Output) Serial Transmission System

● Tie-rod base manifold: 10-SS5V2-W10S1 □ □ D - Stations $\frac{U}{D}$ (R)- C4, N3, C6, N7, C8, N9 (-D)

- When P, E port outlets are indicated on the U side or D side, the P, E ports on the opposite side are plugged.
- External pilot port positions are the same as P, E port outlet positions.

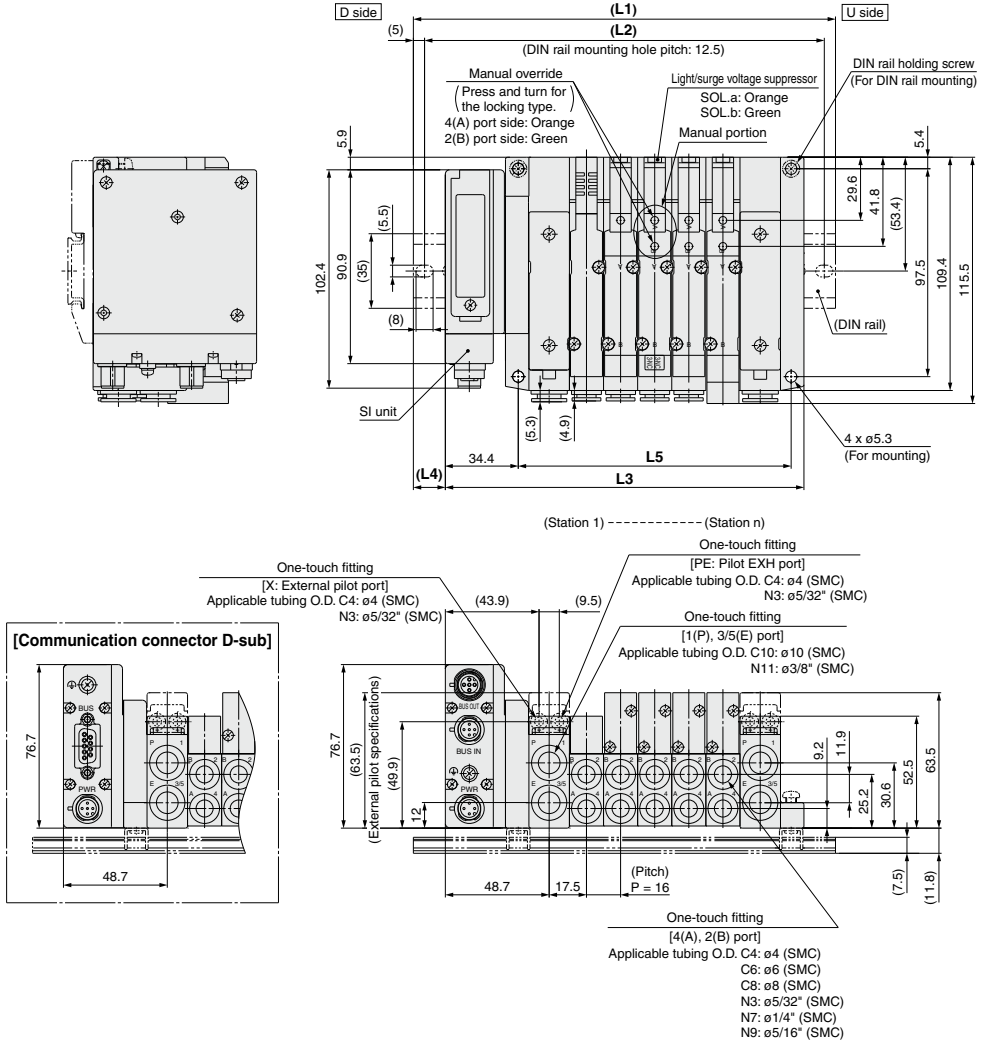

L: DIN Rail Overall Length

L	n: Stations																			
	2	3	4	5	6	7	8	9	10	11	12	13	14	15	16	17	18	19	20	
L1	148	160.5	185.5	198	210.5	235.5	248	260.5	273	298	310.5	323	335.5	360.5	373	385.5	410.5	423	435.5	
L2	137.5	150	175	187.5	200	225	237.5	250	262.5	287.5	300	312.5	325	350	362.5	375	400	412.5	425	
L3	120.2	136.2	152.2	168.2	184.2	200.2	216.2	232.2	248.2	264.2	280.2	296.2	312.2	328.2	344.2	360.2	376.2	392.2	408.2	
L4	14	12	16.5	15	13	17.5	16	14	12.5	17	15	13.5	11.5	16	14.5	12.5	17	15.5	13.5	
L5	80	96	112	128	144	160	176	192	208	224	240	256	272	288	304	320	336	352	368	

Directional Control Valves

Air Cylinders

Rotary Actuators

Air Grippers

Air Preparation Equipment

Modular F. R.

Pressure Control Equipment

Fittings & Tubing

Flow Control Equipment

Pressure Switches/ Pressure Sensors

Dimensions: Series 10-SV3000 for EX260 Integrated-type (For Output) Serial Transmission System

● Tie-rod base manifold: 10-SS5V3-W10S1□□□□-Stations $\frac{U}{D}$ (R) $\frac{C6, N7}{C8, N9, C10, N11}$ (-D)

- When P, E port outlets are indicated on the U side or D side, the P, E ports on the opposite side are plugged.
- External pilot port positions are the same as P, E port outlet positions.

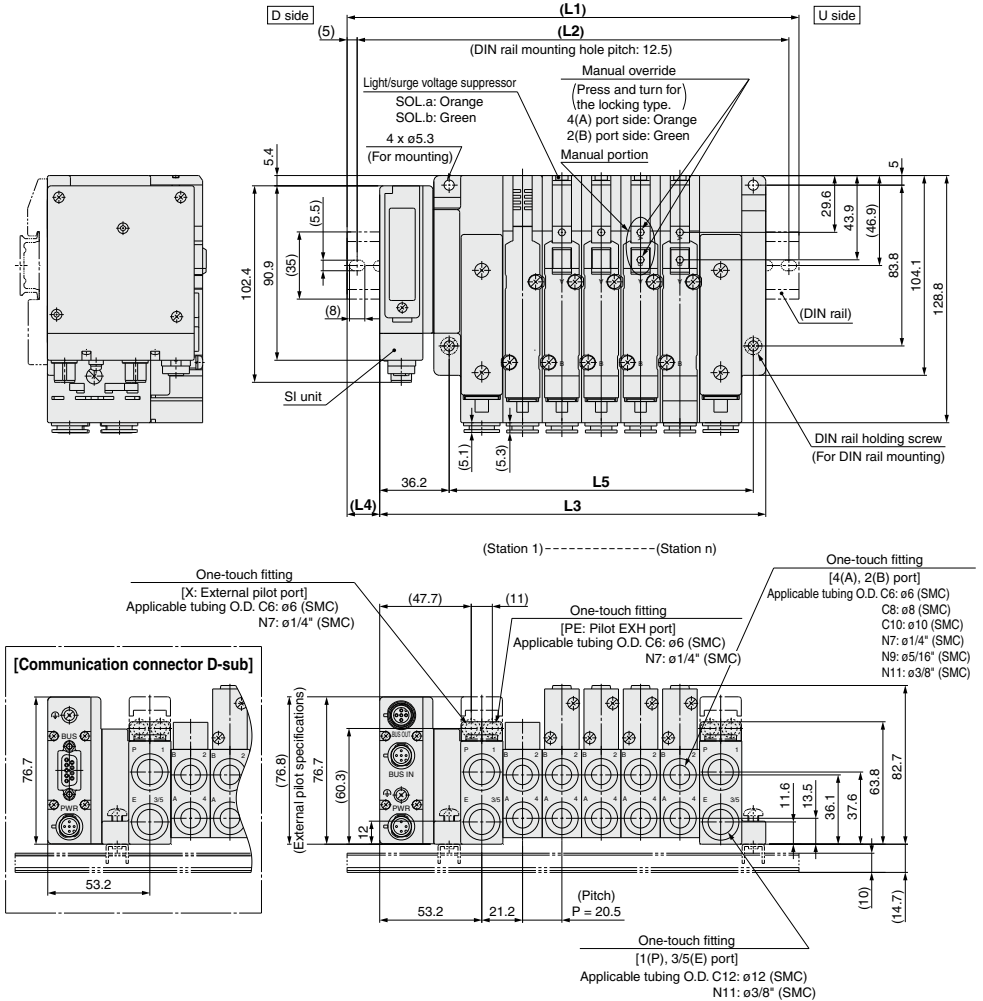

L: DIN Rail Overall Length

L	Stations																			
	2	3	4	5	6	7	8	9	10	11	12	13	14	15	16	17	18	19	20	
L1	173	185.5	210.5	235.5	248	273	298	310.5	335.5	348	373	398	410.5	435.5	460.5	473	498	523	535.5	
L2	162.5	175	200	225	237.5	262.5	287.5	300	325	337.5	362.5	387.5	400	425	450	462.5	487.5	512.5	525	
L3	139.7	160.2	180.7	201.2	221.7	242.2	262.7	283.2	303.7	324.2	344.7	365.2	385.7	406.2	426.7	447.2	467.7	488.2	508.7	
L4	16.5	12.5	15	17	13	15.5	17.5	13.5	16	12	14	16.5	12.5	14.5	17	13	15	17.5	13.5	
L5	97	117.5	138	158.5	179	199.5	220	240.5	261	281.5	302	322.5	343	363.5	384	404.5	425	445.5	466	

Integrated Type (For Output) Serial Transmission System

Series EX126

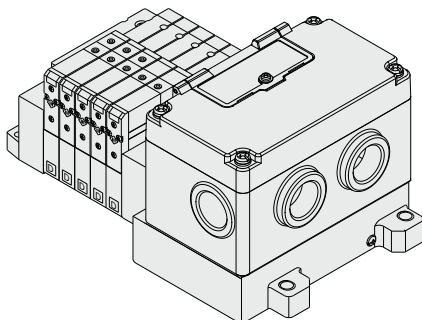

IP67 compliant

Applicable series	Tie-rod base manifold SV1000/SV2000/SV3000
	· Number of outputs: 16

Directional
Control Valves

Air Cylinders

Rotary Actuators

Air Grippers

Air Preparation
Equipment

Modular F. R.

Pressure Control
Equipment

Fittings & Tubing

Flow Control
Equipment

Pressure Switches/
Pressure Sensors

Series 10-SV

EX126 Dedicated Output Serial Wiring



How to Order

● Tie-rod base

10-SS5V **1** - W 10S4 D-05 **U** - -

Series	
1	10-SV1000
2	10-SV2000
3	10-SV3000

● Enclosure
IP67

● SI unit

0	Without SI unit and end plate
VW	CC-Link

- When the SI unit is not included, only the terminal block plate is included.

● Valve stations

Symbol	Stations	Note
02	2 stations	Double wiring ^{Note 1)}
⋮	⋮	
08	8 stations	
02	2 stations	Specified layout ^{Note 2)} (up to 16 solenoids possible.)
⋮	⋮	
16	16 stations	

Note 1) Double wiring: Single, double, 3 position and 4 position solenoid valves can be used on all manifold stations. Use of a single solenoid will result in an unused control signal. If this is not desired, order with a specified layout.

Note 2) Specified layout: Indicate wiring specifications on the manifold specification sheet. (Note that double, 3 and 4 position valves cannot be used where single solenoid wiring has been specified.)

● Mounting

Nil	Direct mounting
D	DIN rail mounting (With DIN rail)
D0 ^{Note)}	DIN rail mounting (Without DIN rail)
D3	For 3 stations
⋮	⋮
D16	For 16 stations

When a longer DIN rail is desired than the specified stations. (Specify a longer rail than the standard length.)
Note) For D0, only DIN rail mounting bracket is attached.

● SUP/EXH block assembly

Nil	Internal pilot
R	External pilot

SI Unit Part No.

Symbol	Protocol type	SI unit part no.
VW	CC-Link	EX126D-SMJ1

Refer to the **WEB catalog** and the Operation Manual for the details of the EX126 Integrated-type (For Output) Serial Transmission System. Please download the Operation Manual via our website, <http://www.smcworld.com>.

● P, E port location

U	U side (2 to 10 stations)
D	D side (2 to 10 stations)
B	Both sides (2 to 16 stations)

● A, B port size (Metric)

Symbol	A, B port	P, E port	Applicable series
C3	ø3.2 One-touch fitting	ø8 One-touch fitting	10-SV1000
C4	ø4 One-touch fitting		
C6	ø6 One-touch fitting		
C4	ø4 One-touch fitting	ø10 One-touch fitting	10-SV2000
C6	ø6 One-touch fitting		
C8	ø8 One-touch fitting		
C6	ø6 One-touch fitting	ø12 One-touch fitting	10-SV3000
C8	ø8 One-touch fitting		
C10	ø10 One-touch fitting		
M	Mixed		

● A, B port size (Inch)

Symbol	A, B port	P, E port	Applicable series
N1	ø1/8" One-touch fitting	ø5/16" One-touch fitting	10-SV1000
N3	ø5/32" One-touch fitting		
N7	ø1/4" One-touch fitting		
N3	ø5/32" One-touch fitting	ø3/8" One-touch fitting	10-SV2000
N7	ø1/4" One-touch fitting		
N9	ø5/16" One-touch fitting		
N7	ø1/4" One-touch fitting	ø3/8" One-touch fitting	10-SV3000
N9	ø5/16" One-touch fitting		
N11	ø3/8" One-touch fitting		
M	Mixed		

* For mixed specifications (M), indicate separately on the manifold specification sheet.

* External pilot type (R) X, PE port sizes are ø4 (metric), ø5/32" (inch) for the 10-SV1000/2000 series and ø6 (metric), ø1/4" (inch) for the 10-SV3000 series.

How to Order Manifold Assembly

Ordering example (10-SV1000)

Manifold
10-SS5V1-W10S4VWD-05B-C6 (1 set)

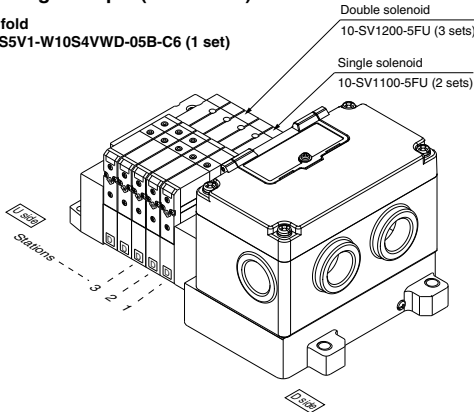

10-SS5V1-W10S4VWD-05B-C6 1 set (manifold part no.)
 * **10-SV1100-5FU** 2 sets (manifold part no.)
 * **10-SV1200-5FU** 3 sets (manifold part no.)

How to Order Valve

10-SV 1 1 00 [] [] - **5 F** [] [] - [] - []

Series

1	10-SV1000
2	10-SV2000
3	10-SV3000

Actuation type

1	2 position single
2	2 position double
3	3 position closed center
4	3 position exhaust center
5	3 position pressure center
A	4 position dual 3 port valve: N.C./N.C.
B	4 position dual 3 port valve: N.O./N.O.
C	4 position dual 3 port valve: N.C./N.O.

* 4 position dual 3 port valves are applicable to the 10-SV1000 and 10-SV2000 series only.

Pilot type

Nil	Internal pilot
R	External pilot

* External pilot specifications are not available for 4 position dual 3 port valves.

Back pressure check valve

Nil	None
K	Built-in

* The built-in back pressure check valve type is applicable to the 10-SV1000 series only.
 * The product with back pressure check valve is not available for 3 position valves.

Rated voltage

5	24 VDC
---	--------

Note) Available with manifold block for station additions. Refer to the WEB catalog.

Made to Order

Nil	—
X90	Main valve fluororubber (Refer to page 272.)

Manual override

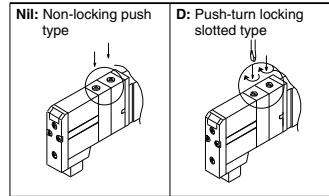

Light/Surge voltage suppressor

U	With light/surge voltage suppressor
R	With surge voltage suppressor

Note) Refer to the Specific Product Precautions 2 on page 274.

Directional Control Valves
 Air Cylinders
 Rotary Actuators
 Air Grippers
 Air Preparation Equipment
 Modular F. R.
 Pressure Control Equipment
 Fittings & Tubing
 Flow Control Equipment
 Pressure Switches/ Pressure Sensors

Dimensions: Series 10-SV1000 for EX126 Integrated-type (For Output) Serial Transmission System

● Tie-rod base manifold: 10-SS5V1-W10S4 □ D- Stations $\frac{U}{B}$ (R) $\frac{C3, N1}{C4, N3}$ $\frac{N8}{C6, N7}$ (-D)

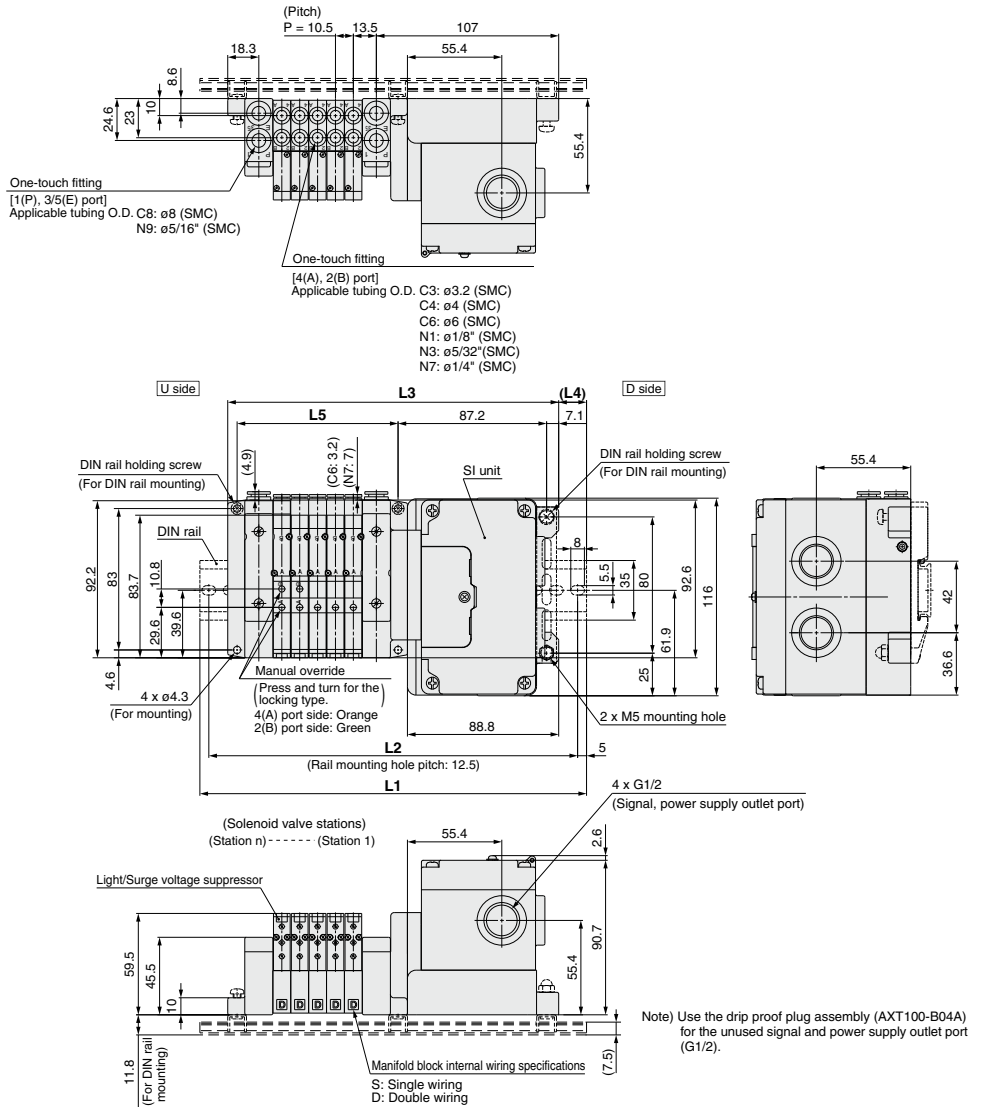

L Dimension

n	2	3	4	5	6	7	8	9	10	11	12	13	14	15	16
L1	198	198	210.5	223	235.5	248	260.5	260.5	273	285.5	298	310.5	323	323	335.5
L2	187.5	187.5	200	212.5	225	237.5	250	250	262.5	275	287.5	300	312.5	312.5	325
L3	162.8	173.3	183.8	194.3	204.8	215.3	225.8	236.3	246.8	257.3	267.8	278.3	288.8	299.3	309.8
L4	17.5	12.5	13.5	14.5	15.5	16.5	17.5	12	13	14	15	16	17	12	13
L5	63	73.5	84	94.5	105	115.5	126	136.5	147	157.5	168	178.5	189	199.5	210

Dimensions: Series 10-SV2000 for EX126 Integrated-type (For Output) Serial Transmission System

● Tie-rod base manifold: 10-SS5V2-W10S4 □ D-^UStations_B(R)^{CA, NB} / ^{CS, NS} (-D)

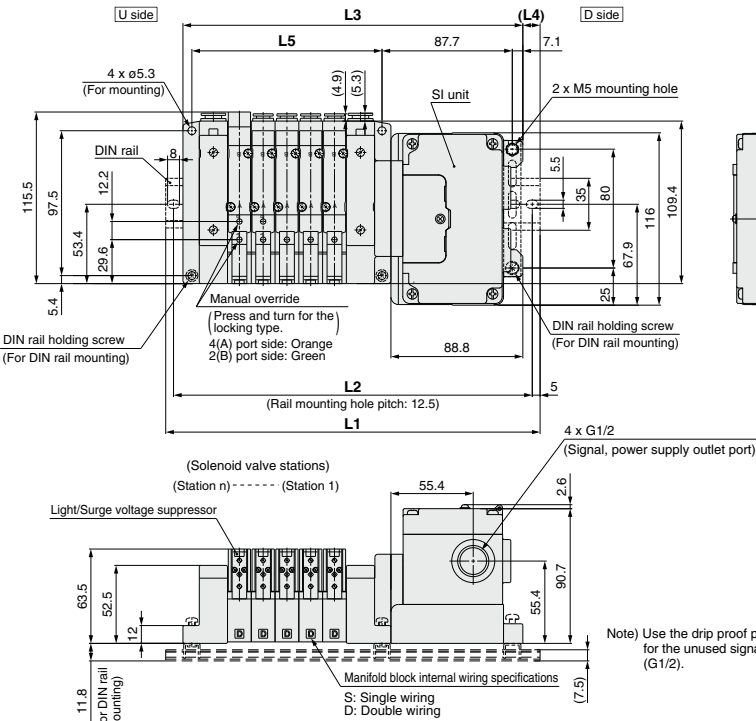
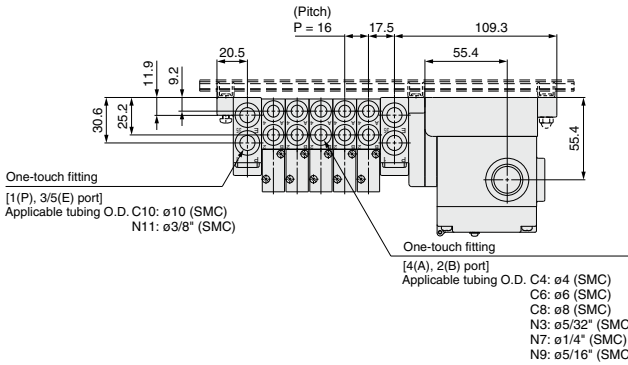

L Dimension

n	2	3	4	5	6	7	8	9	10	11	12	13	14	15	16
L1	210.5	223	248	260.5	273	285.5	310.5	323	335.5	348	373	385.5	398	423	435.5
L2	200	212.5	237.5	250	262.5	275	300	312.5	325	337.5	362.5	375	387.5	412.5	425
L3	180.8	196.8	212.8	228.8	244.8	260.8	276.8	292.8	308.8	324.8	340.8	356.8	372.8	388.8	404.8
L4	15	13	17.5	16	14	12.5	17	15	13.5	11.5	16	14.5	12.5	17	15.5
L5	80	96	112	128	144	160	176	192	208	224	240	256	272	288	304

n: Stations

Directional Control Valves
Air Cylinders
Rotary Actuators
Air Grippers
Air Preparation Equipment
Modular F. R.
Pressure Control Equipment
Fittings & Tubing
Flow Control Equipment
Pressure Switches/ Pressure Sensors

Dimensions: Series 10-SV3000 for EX126 Integrated-type (For Output) Serial Transmission System

● Tie-rod base manifold: 10-SS5V3-W10S4 □ D-Stations_U^R (R) ^{C6, N7}_{C8, N9} ^{C10, N11} (-D)

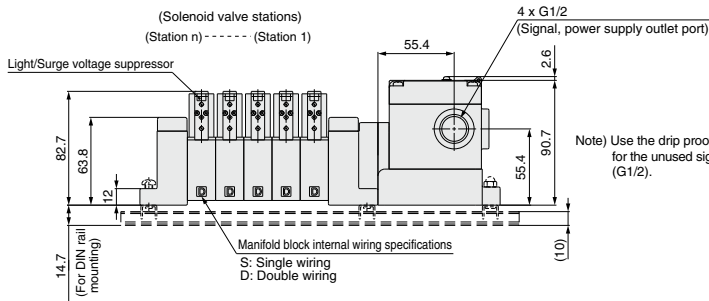
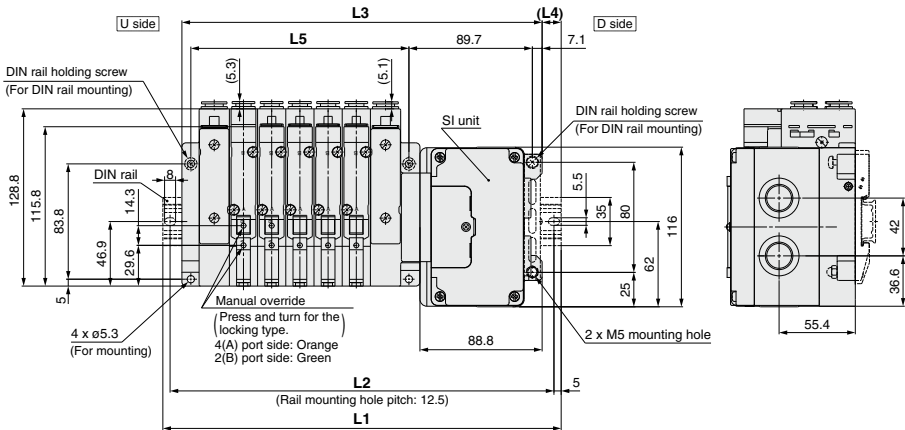
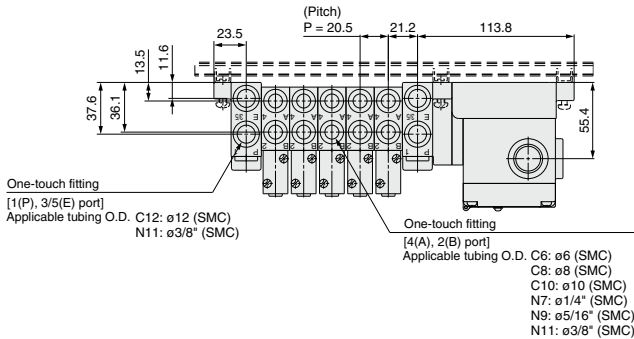

L Dimension

n	2	3	4	5	6	7	8	9	10	11	12	13	14	15	16
L1	235.5	248	273	285.5	310.5	335.5	348	373	398	410.5	435.5	460.5	473	498	510.5
L2	225	237.5	262.5	275	300	325	337.5	362.5	387.5	400	425	450	462.5	487.5	500
L3	200.3	220.8	241.3	261.8	282.3	302.8	323.3	343.8	364.3	384.8	405.3	425.8	446.3	466.8	487.3
L4	17.5	13.5	16	12	14	16.5	12.5	14.5	17	13	15	17.5	13.5	15.5	11.5
L5	97	117.5	138	158.5	179	199.5	220	240.5	261	281.5	302	322.5	343	363.5	384

Circular Connector

IP67 compliant

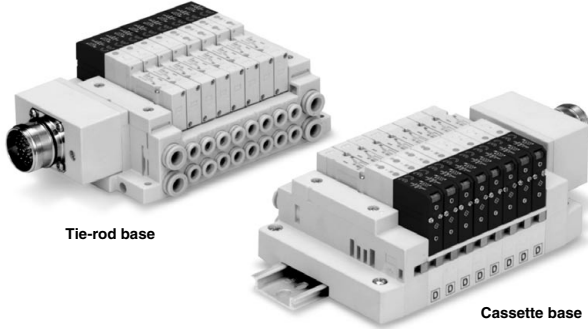

Applicable series	Cassette base manifold 10-SV1000/10-SV2000
	Tie-rod base manifold 10-SV1000/10-SV2000/10-SV3000/10-SV4000
· Number of connectors: 26 pins	

Directional Control Valves

Air Cylinders

Rotary Actuators

Air Grippers

Air Preparation Equipment

Modular F. R.

Pressure Control Equipment

Fittings & Tubing

Flow Control Equipment

Pressure Switches/
Pressure Sensors

Series 10-SV

Circular Connector



How to Order

Series

1	10-SV1000
2	10-SV2000
3	10-SV3000
4	10-SV4000

Valve stations

Symbol	Stations	Note
02	2 stations	Double wiring (Note 1)
:	:	
12	12 stations	Specified layout (Note 2) (Up to 24 solenoids possible)
02	2 stations	
:	:	
20	20 stations	

Tie-rod base
10 - SS5V 1 - W 10CD - 05 U

Cassette base
10 - SS5V 1 - W 16CD - 05 U

Clean series

1	10-SV1000
2	10-SV2000

Enclosure IP67

Stations

Type 16: Series 10-SV1000

Symbol	Stations	Note
02	2 stations	Double wiring (Note 1)
:	:	
09	9 stations	Specified layout (Note 2) (Up to 18 solenoids possible)
02	2 stations	
:	:	
18	18 stations	

Type 16: Series 10-SV2000

Symbol	Stations	Note
02	2 stations	Double wiring (Note 1)
:	:	
12	12 stations	Specified layout (Note 2) (Up to 24 solenoids possible)
02	2 stations	
:	:	
20	20 stations	

Note 1 Double wiring: Single, double, 3 position and 4 position solenoid valves can be used at all of the manifold stations. Use of a single solenoid will result in an unused control signal. If this is not desired, order with a specified layout.

Note 2 Specified layout: Indicate wiring specifications on the manifold specification sheet. (Note that double, 3 and 4 position valves cannot be used where single solenoid wiring has been specified.)

Mounting

Nil	Direct mounting
D	DIN rail mounting (With DIN rail)
D0 (Note)	DIN rail mounting (Without DIN rail)
D3	For 3 stations When a longer DIN rail is desired than the specified stations. (Specify a longer rail than the standard length.)
:	:
D20	For 20 stations

Note For D0, only DIN rail mounting bracket is attached.

DIN rail length specified

Nil	Standard length
3	For 3 stations Specify a longer rail than the standard length.
:	:
20 (Note)	For 20 stations

Note Able to specify the length for 3 stations up to 18 stations for 10-SV1000, which is available with 18 stations at the maximum.

A, B port size (Metric)

Symbol	Specifications	P, E port	Applicable series
C3	ø3.2 One-touch fitting	ø8 One-touch fitting	10-SV1000
C4	ø4 One-touch fitting		
C6	ø6 One-touch fitting		
C4	ø4 One-touch fitting	ø10 One-touch fitting	10-SV2000
C6	ø6 One-touch fitting		
C8	ø8 One-touch fitting	ø12 One-touch fitting	10-SV3000
C6	ø6 One-touch fitting		
C8	ø8 One-touch fitting	ø12 One-touch fitting	10-SV4000
C10	ø10 One-touch fitting		
C8	ø8 One-touch fitting	Rc 3/8	10-SV4000
C10	ø10 One-touch fitting		
C12	ø12 One-touch fitting	G 3/8	10-SV4000
02	Rc 1/4		
03	Rc 3/8		
02F	G 1/4		
03F	G 3/8		
M	Mixed		

A, B port size (Inch)

Symbol	Specifications	P, E port	Applicable series
N1	ø1/8" One-touch fitting	ø5/16" One-touch fitting	10-SV1000
N3	ø5/32" One-touch fitting		
N7	ø1/4" One-touch fitting	ø3/8" One-touch fitting	10-SV2000
N3	ø5/32" One-touch fitting		
N7	ø1/4" One-touch fitting	ø3/8" One-touch fitting	10-SV3000
N9	ø5/16" One-touch fitting		
N7	ø1/4" One-touch fitting	ø3/8" One-touch fitting	10-SV4000
N9	ø5/16" One-touch fitting		
N11	ø3/8" One-touch fitting	NPT 3/8	10-SV4000
N9	ø5/16" One-touch fitting		
N11	ø3/8" One-touch fitting	NPTF 3/8	10-SV4000
N9	ø5/16" One-touch fitting		
02N	NPT 1/4		
03N	NPT 3/8		
02T	NPTF 1/4		
03T	NPTF 3/8		
M	Mixed		

P, E port location

U	U side (2 to 10 stations)
D	D side (2 to 10 stations)
B	Both sides (2 to 20 stations)

SUP/EXH block assembly

Nil	Internal pilot
R	External pilot

How to Order Manifold Assembly

Ordering example (10-SV1000)

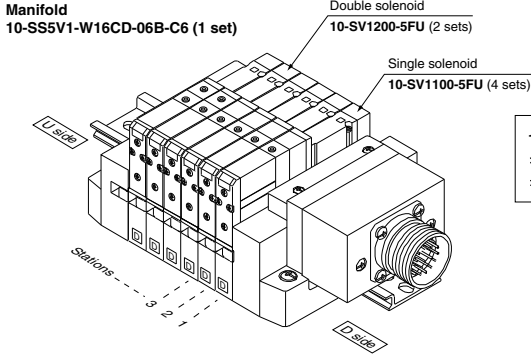

10-SS5V1-W16CD-06B-C6.....1 set (Manifold part no.)
 * 10-SV1100-5FU.....4 sets (Single solenoid part no.)
 * 10-SV1200-5FU.....2 sets (Double solenoid part no.)

How to Order Solenoid Valve

10-SV 1 1 00 **5 F** (Note)

Clean series

Series

1	10-SV1000
2	10-SV2000
3	10-SV3000
4	10-SV4000

Actuation type

1	2 position single solenoid
2	2 position double solenoid
3	3 position closed center
4	3 position exhaust center
5	3 position pressure center
A	4 position dual 3 port valve: N.C./N.C.
B	4 position dual 3 port valve: N.O./N.O.
C	4 position dual 3 port valve: N.C./N.O.

* 4 position dual 3 port valves are applicable to the 10-SV1000 and 10-SV2000 series only.

Pilot type

Nil	Internal pilot
R	External pilot

* External pilot specifications are not available for 4 position dual 3 port valves.

Back pressure check valve

Nil	None
K	Built-in

* The built-in back pressure check valve type is applicable to the 10-SV1000 series only.
 * The product with back pressure check valve is not available for 3 position solenoid valves.

Rated voltage

5	24 VDC
6	12 VDC

Note) Available with manifold block for station additions. Refer to the **WEB catalog**.

Made to Order

Nil	—
X90	Main valve fluororubber (Refer to page 272.)

Manual override

Nil: Non-locking push type D: Push-turn locking slotted type

Light/surge voltage suppressor

U	With light/surge voltage suppressor
R	With surge voltage suppressor

Note) Refer to the Specific Product Precautions 2 on page 274.

Directional Control Valves
 Air Cylinders
 Rotary Actuators
 Air Grippers
 Air Preparation Equipment
 Modular F. R.
 Pressure Control Equipment
 Fittings & Tubing
 Flow Control Equipment
 Pressure Switches/ Pressure Sensors

Manifold Electrical Wiring

10C/16C Circular Connector Type (26 pins)

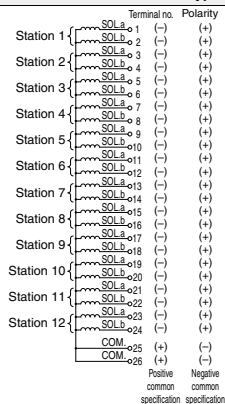

- This circuit is for the double wiring specification with up to 12 stations. Since the usable number of solenoids differs depending on the manifold type, refer to the table below. For single solenoids, connect to SOL.A. Furthermore, when wiring is specified on the manifold specification sheet, connections are made without skipping any connectors, and signals A for single and A, B for double are in order 1 → 2 → 3 → 4, etc.
- Stations are counted from the D side (connector side) as the 1st one.
- Since solenoid valves do not have polarity, either the +COM or -COM can be used.

Usable No. of Solenoids

Model	Max. no. of solenoids
Type 10, Tie-rod base	24
Type 16, Cassette base	18
	24

Dimensions: Series 10-SV1000 for Circular Connector

• **Cassette base manifold: 10-SS5V1-W16CD-** Stations $\frac{U}{D}$ (R) - C3, N1
C4, N3
C6, N7

• When P, E port outlets are indicated on the U side or D side, the P, E ports on the opposite side are plugged.
• External pilot port positions are the same as P, E port outlet positions.

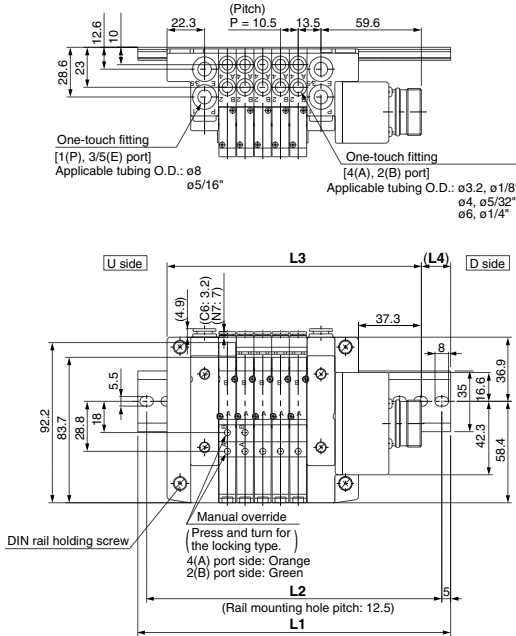

With external pilot specifications

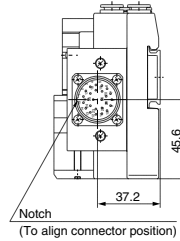
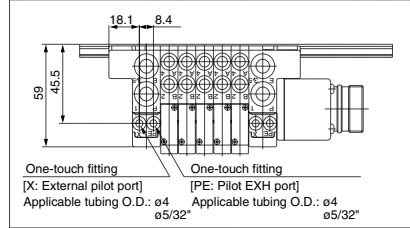

With option

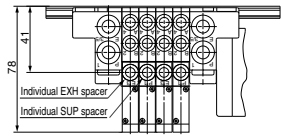
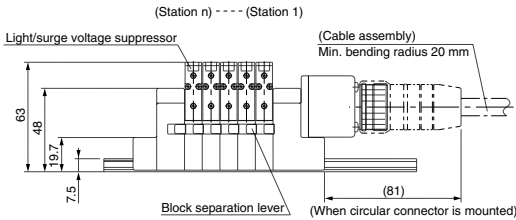

L Dimension

n: Stations

L	2	3	4	5	6	7	8	9	10	11	12	13	14	15	16	17	18
L1	148	160.5	173	185.5	185.5	198	210.5	223	235.5	248	248	260.5	273	285.5	298	310.5	310.5
L2	137.5	150	162.5	175	175	187.5	200	212.5	225	237.5	237.5	250	262.5	275	287.5	300	300
L3	119.3	129.8	140.3	150.8	161.3	171.8	182.3	192.8	203.3	213.8	224.3	234.8	245.3	255.8	266.3	276.8	287.3
L4	14.5	15.5	16.5	17.5	12	13	14	15	16	17	12	13	14	15	16	17	11.5

Directional Control Valves

Air Cylinders

Rotary Actuators

Air Grippers

Air Preparation Equipment

Modular F. R.

Pressure Control Equipment

Fittings & Tubing

Flow Control Equipment

Pressure Switches/ Pressure Sensors

Dimensions: Series 10-SV2000 for Circular Connector

• **Cassette base manifold: 10-SS5V2-W16CD-**

U	D
⊖	⊕

(R) - C4, N3
C6, N7
C8, N9

• When P, E port outlets are indicated on the U side or D side, the P, E ports on the opposite side are plugged.
• External pilot port positions are the same as P, E port outlet positions.

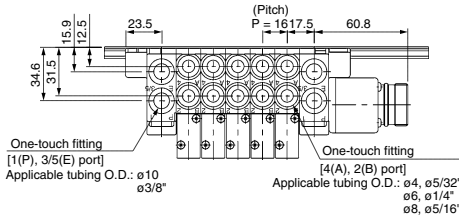

With external pilot specifications

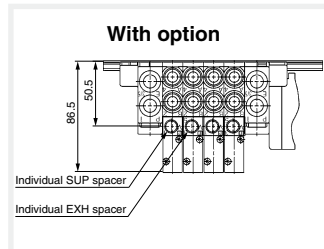
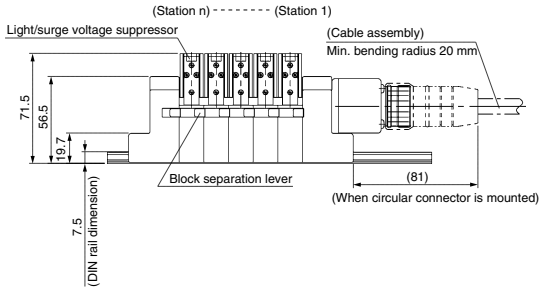
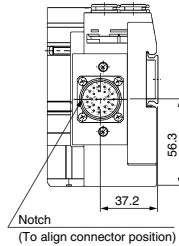
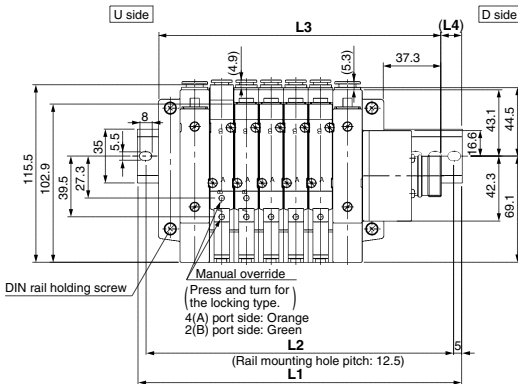
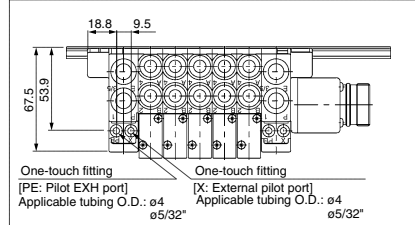

L Dimension

n: Stations

n	2	3	4	5	6	7	8	9	10	11	12	13	14	15	16	17	18	19	20
L1	160.5	185.5	198	210.5	223	248	260.5	273	298	310.5	323	335.5	360.5	373	385.5	410.5	423	435.5	448
L2	150	175	187.5	200	212.5	237.5	250	262.5	287.5	300	312.5	325	350	362.5	375	400	412.5	425	437.5
L3	135.3	151.3	167.3	183.3	199.3	215.3	231.3	247.3	263.3	279.3	295.3	311.3	327.3	343.3	359.3	375.3	391.3	407.3	423.3
L4	12.5	17	15.5	13.5	12	16.5	14.5	13	17.5	15.5	14	12	16.5	15	13	17.5	16	14	12.5

Dimensions: Series 10-SV1000 for Circular Connector

• Tie-rod base manifold: 10-SS5V1-W10CD- Stations $\begin{matrix} U \\ D \end{matrix}$ **(R)** - $\begin{matrix} C3, N1 \\ C4, N3 \\ C6, N7 \end{matrix}$ **(-D)**

When P, E port outlets are indicated on the U side or D side, the P, E ports on the opposite side are plugged.
External pilot port positions are the same as P, E port outlet positions.

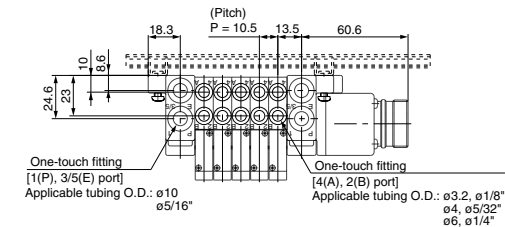

With external pilot specifications

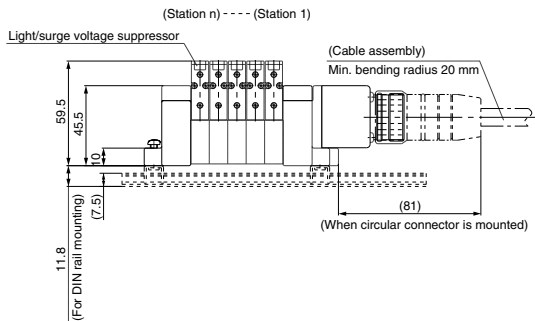
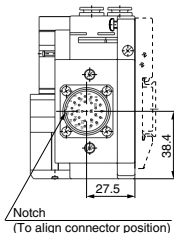
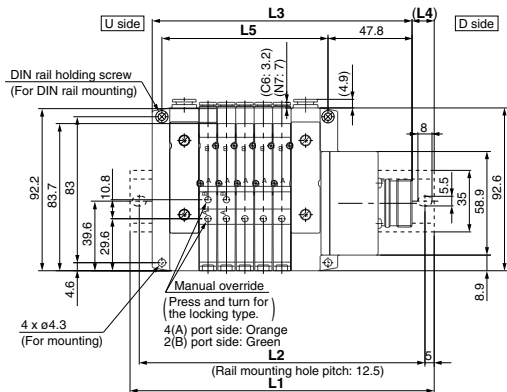
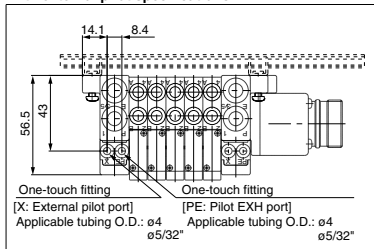

With option

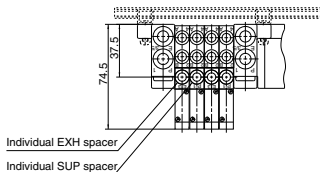

L Dimension

$\begin{matrix} L \\ n \end{matrix}$	2	3	4	5	6	7	8	9	10	11	12	13	14	15	16	17	18	19	20
L1	148	160.5	160.5	173	185.5	198	210.5	223	235.5	235.5	248	260.5	273	285.5	298	298	310.5	323	335.5
L2	137.5	150	150	162.5	175	187.5	200	212.5	225	225	237.5	250	262.5	275	287.5	287.5	300	312.5	325
L3	116.3	126.8	137.3	147.8	158.3	168.8	179.3	189.8	200.3	210.8	221.3	231.8	242.3	252.8	263.3	273.8	284.3	294.8	305.3
L4	16	17	11.5	12.5	13.5	14.5	15.5	16.5	17.5	12.5	13.5	14.5	15.5	16.5	17.5	12	13	14	15
L5	63	73.5	84	94.5	105	115.5	126	136.5	147	157.5	168	178.5	189	199.5	210	220.5	231	241.5	252

n: Stations

Directional Control Valves

Air Cylinders

Rotary Actuators

Air Grippers

Air Preparation Equipment

Modular F. R.

Pressure Control Equipment

Fittings & Tubing

Flow Control Equipment

Pressure Switches/Pressure Sensors

Dimensions: Series 10-SV2000 for Circular Connector

• Tie-rod base manifold: 10-SS5V2-W10CD-**Stations** $\begin{matrix} U \\ D \end{matrix}$ (R) - $\begin{matrix} C4, N3 \\ C6, N7 \\ C8, N9 \end{matrix}$ (-D)

• When P, E port outlets are indicated on the U side or D side, the P, E ports on the opposite side are plugged.
 • External pilot port positions are the same as P, E port outlet positions.

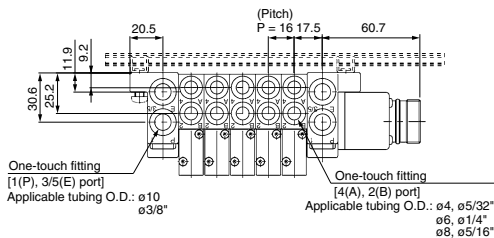

With external pilot specifications

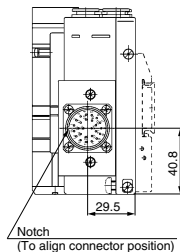
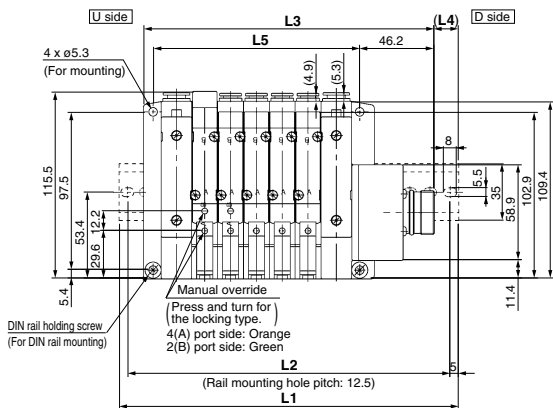
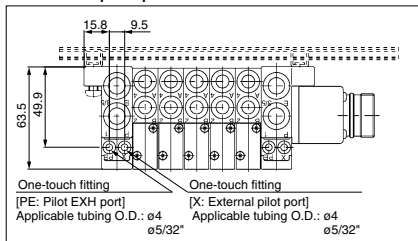

(Station n) - - - - - (Station 1)

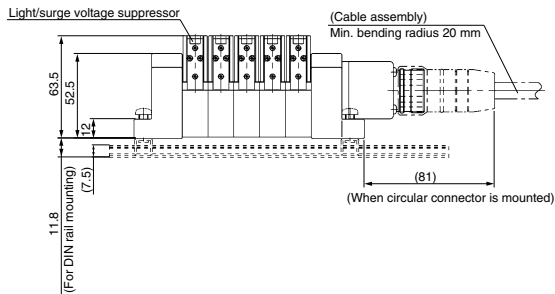

With option

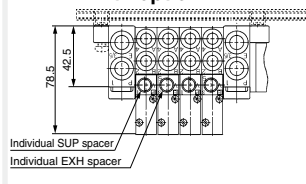

L Dimension

n: Stations

n	2	3	4	5	6	7	8	9	10	11	12	13	14	15	16	17	18	19	20
L1	160.5	173	198	210.5	223	235.5	260.5	273	285.5	310.5	323	335.5	348	373	385.5	398	423	435.5	448
L2	150	162.5	187.5	200	212.5	225	250	262.5	275	300	312.5	325	337.5	362.5	375	387.5	412.5	425	437.5
L3	132.2	148.2	164.2	180.2	196.2	212.2	228.2	244.2	260.2	276.2	292.2	308.2	324.2	340.2	356.2	372.2	388.2	404.2	420.2
L4	14	12.5	17	15	13.5	11.5	16	14.5	12.5	17	15.5	13.5	12	16.5	14.5	13	17.5	15.5	14
L5	80	96	112	128	144	160	176	192	208	224	240	256	272	288	304	320	336	352	368

Dimensions: Series 10-SV3000 for Circular Connector

• Tie-rod base manifold: 10-SS5V3-W10CD- $\begin{matrix} \text{U} \\ \text{D} \end{matrix}$ (R) - $\begin{matrix} \text{C6, N7} \\ \text{C8, N9} \\ \text{C10, N11} \end{matrix}$ (-D)

• When P, E port outlets are indicated on the U side or D side, the P, E ports on the opposite side are plugged.
 • External pilot port positions are the same as P, E port outlet positions.

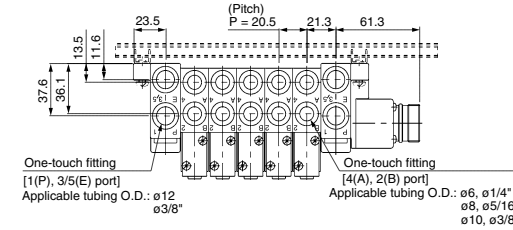

With external pilot specifications

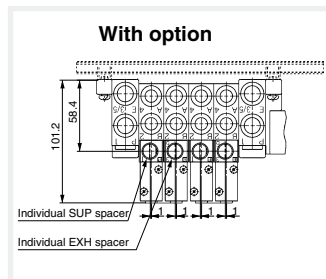
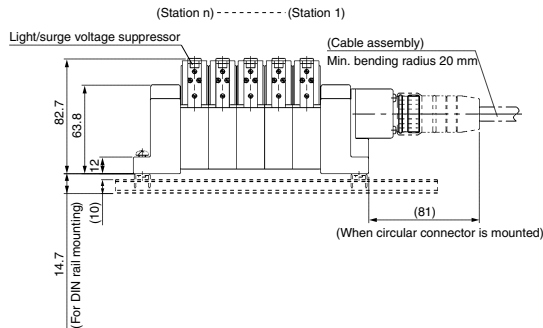
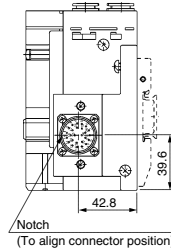
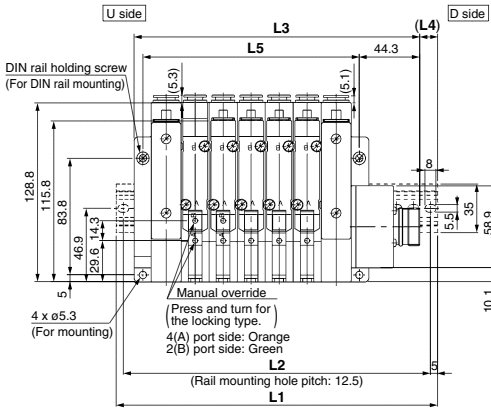
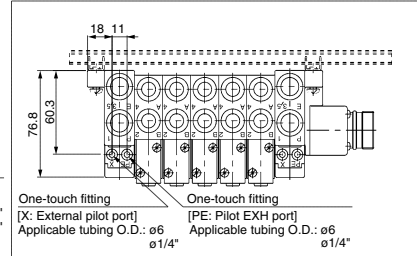

L Dimension

n: Stations

n	2	3	4	5	6	7	8	9	10	11	12	13	14	15	16	17	18	19	20
L1	173	198	223	235.5	260.5	285.5	298	323	335.5	360.5	385.5	398	423	448	460.5	485.5	510.5	523	548
L2	162.5	187.5	212.5	225	250	275	287.5	312.5	325	350	375	387.5	412.5	437.5	450	475	500	512.5	537.5
L3	147.8	168.3	188.8	209.3	229.8	250.3	270.8	291.3	311.8	332.3	352.8	373.3	393.8	414.3	434.8	455.3	475.8	496.3	516.8
L4	12.5	15	17	13	15.5	17.5	13.5	16	12	14	16.5	12.5	14.5	17	13	15	17.5	13.5	15.5
L5	97	117.5	138	158.5	179	199.5	220	240.5	261	281.5	302	322.5	343	363.5	384	404.5	425	445.5	466

Directional Control Valves
Air Cylinders
Rotary Actuators
Air Grippers
Air Preparation Equipment
Modular F. R.
Pressure Control Equipment
Fittings & Tubing
Flow Control Equipment
Pressure Switches/ Pressure Sensors

Dimensions: Series 10-SV4000 for Circular Connector

• Tie-rod base manifold: 10-SS5V4-W10CD- **Stations** $\frac{U}{D}$ (R) - $\frac{02}{03}$ $\frac{C8, N9}{C10, N11}$ (-D)

When P, E port outlets are indicated on the U side or D side, the P, E ports on the opposite side are plugged.
External pilot port positions are the same as P, E port outlet positions.

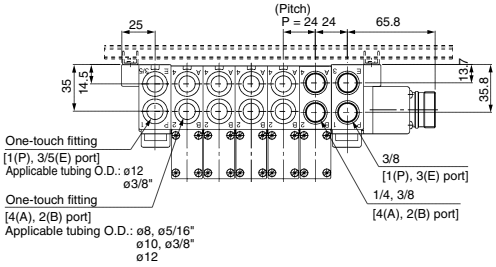

With external pilot specifications

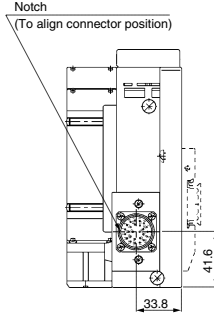
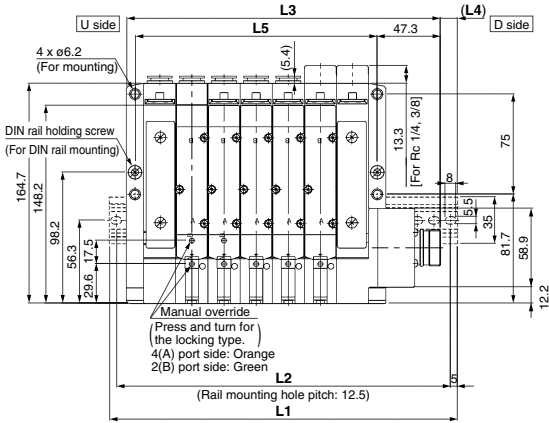
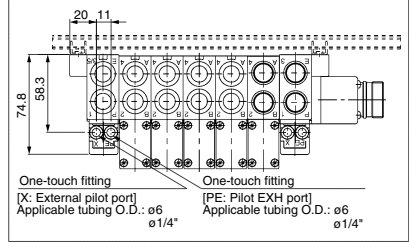

(Station n) ----- (Station 1)

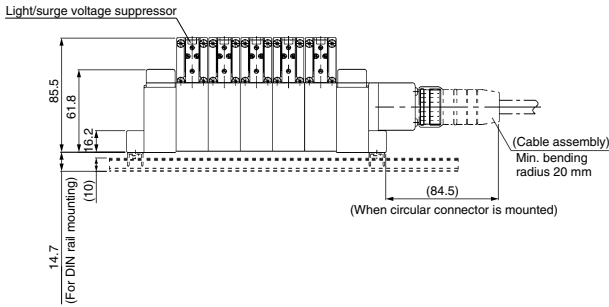

With option

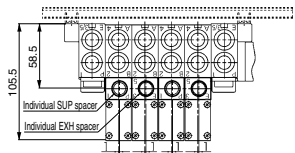

L Dimension

n: Stations

n	2	3	4	5	6	7	8	9	10	11	12	13	14	15	16	17	18	19	20
L1	198	210.5	235.5	260.5	285.5	310.5	335.5	360.5	385.5	410.5	435.5	460.5	485.5	498	523	548	573	598	623
L2	187.5	200	225	250	275	300	325	350	375	400	425	450	475	487.5	512.5	537.5	562.5	587.5	612.5
L3	162.8	186.8	210.8	234.8	258.8	282.8	306.8	330.8	354.8	378.8	402.8	426.8	450.8	474.8	498.8	522.8	546.8	570.8	594.8
L4	17.5	12	12.5	13	13.5	14	14.5	15	15.5	16	16.5	17	17.5	11.5	12	12.5	13	13.5	14
L5	109	133	157	181	205	229	253	277	301	325	349	373	397	421	445	469	493	517	541

D-sub Connector

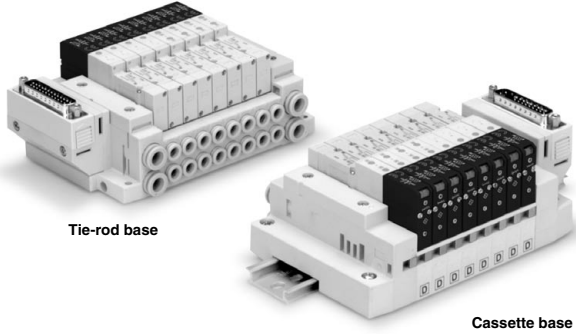

Tie-rod base

Cassette base

Applicable series	Cassette base manifold 10-SV1000/10-SV2000
	Tie-rod base manifold 10-SV1000/10-SV2000/10-SV3000/10-SV4000
<ul style="list-style-type: none"> · Number of connectors: 25 pins · MIL-C-24308 · Conforming to JIS-X-5101 	

Directional Control Valves

Air Cylinders

Rotary Actuators

Air Grippers

Air Preparation Equipment

Modular F. R.

Pressure Control Equipment

Fittings & Tubing

Flow Control Equipment

Pressure Switches/ Pressure Sensors

Series 10-SV D-sub Connector



How to Order

Series

1	10-SV1000
2	10-SV2000
3	10-SV3000
4	10-SV4000

Valve stations

Symbol	Stations	Note
02	2 stations	Double wiring ^{Note 1)}
:	:	
:	:	
11	11 stations	Specified layout ^{Note 2)} (Up to 23 solenoids possible)
02	2 stations	
:	:	
20	20 stations	

Tie-rod base
10-SS5V 1-10FD 1-05U

Cassette base
10-SS5V 1-16FD 1-05U

Clean series

1	10-SV1000
2	10-SV2000

Connector entry direction

1	Upward
2	Lateral

Valve stations

Series 10-SV1000

Symbol	Stations	Note
02	2 stations	Double wiring ^{Note 1)}
:	:	
:	:	
09	9 stations	Specified layout ^{Note 2)} (Up to 18 solenoids possible)
02	2 stations	
:	:	
18	18 stations	

Series 10-SV2000

Symbol	Stations	Note
02	2 stations	Double wiring ^{Note 1)}
:	:	
:	:	
11	11 stations	Specified layout ^{Note 2)} (Up to 23 solenoids possible)
02	2 stations	
:	:	
20	20 stations	

P, E port location

U	U side (2 to 10 stations)
D	D side (2 to 20 stations)
B	Both sides (2 to 20 stations)

Pilot type

Nil	Internal pilot
R	External pilot

A, B port size (Metric)

Symbol	A, B port	P, E port	Applicable series
C3	ø3.2 One-touch fitting	ø8 One-touch fitting	10-SV1000
C4	ø4 One-touch fitting		
C6	ø6 One-touch fitting		
C4	ø4 One-touch fitting	ø10 One-touch fitting	10-SV2000
C6	ø6 One-touch fitting		
C8	ø8 One-touch fitting		
C6	ø6 One-touch fitting	ø12 One-touch fitting	10-SV3000
C8	ø8 One-touch fitting		
C10	ø10 One-touch fitting		
C8	ø8 One-touch fitting	ø12 One-touch fitting	10-SV4000
C10	ø10 One-touch fitting		
C12	ø12 One-touch fitting		
02	Rc 1/4	Rc 3/8	10-SV4000
03	Rc 3/8		
02F	G 1/4		
03F	G 3/8		
M	Mixed		

A, B port size (Inch)

Symbol	A, B port	P, E port	Applicable series
N1	ø1/8" One-touch fitting	ø5/16" One-touch fitting	10-SV1000
N3	ø5/32" One-touch fitting		
N7	ø1/4" One-touch fitting		
N3	ø5/32" One-touch fitting	ø3/8" One-touch fitting	10-SV2000
N7	ø1/4" One-touch fitting		
N9	ø5/16" One-touch fitting		
N7	ø1/4" One-touch fitting	ø3/8" One-touch fitting	10-SV3000
N9	ø5/16" One-touch fitting		
N11	ø3/8" One-touch fitting		
N9	ø5/16" One-touch fitting	ø3/8" One-touch fitting	10-SV4000
N11	ø3/8" One-touch fitting		
02N	NPT 1/4		
03N	NPT 3/8		
02T	NPTF 1/4		
03T	NPTF 3/8		
M	Mixed		

Note 1) Double wiring: Single, double, 3 position and 4 position solenoid valves can be used at all of the manifold stations. Use of a single solenoid will result in an unused control signal. If this is not desired, order with a specified layout.

Note 2) Specified layout: Indicate wiring specifications on the manifold specification sheet. (Note that double, 3 and 4 position valves cannot be used where single solenoid wiring has been specified.)

Note 1) Double wiring: Single, double, 3 position and 4 position solenoid valves can be used at all of the manifold stations. Use of a single solenoid will result in an unused control signal. If this is not desired, order with a specified layout.

Note 2) Specified layout: Indicate wiring specifications on the manifold specification sheet. (Note that double, 3 and 4 position valves cannot be used where single solenoid wiring has been specified.)

Mounting

Nil	Direct mounting
D	DIN rail mounting (With DIN rail)
D0 ^{Note)}	DIN rail mounting (Without DIN rail)
D3	For 3 stations (When a longer DIN rail is desired than the specified stations. (Specify a longer rail than the standard length.)
:	:
D20	For 20 stations

DIN rail length specified

Nil	Standard length
3	For 3 stations
:	:
20 ^{Note)}	For 20 stations

Note) Able to specify the length for 3 stations up to 18 stations for 10-SV1000, which is available with 18 stations at the maximum.

* For mixed specifications (M), indicate separately on the manifold specification sheet.

* External pilot type (R) X, PE port sizes are ø4 (metric), ø5/32" (inch) for the 10-SV1000/2000 series and ø6 (metric), ø1/4" (inch) for the 10-SV3000/4000 series.

How to Order Manifold Assembly

Ordering example (10-SV1000)

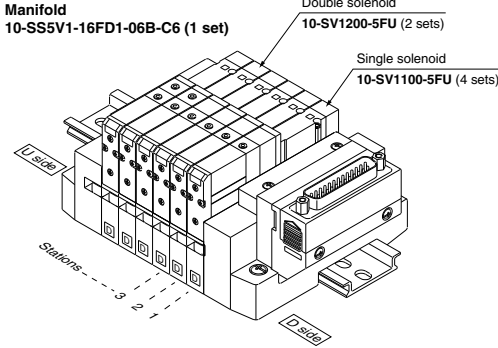

10-SS5V1-16FD1-06B-C6.....1 set (Manifold part no.)
 * 10-SV1100-5FU.....4 sets (Single solenoid part no.)
 * 10-SV1200-5FU.....2 sets (Double solenoid part no.)

How to Order Solenoid Valve

10 - SV 1 1 00 - 5 F - (Note)

Clean series

1	10-SV1000
2	10-SV2000
3	10-SV3000
4	10-SV4000

Series

Actuation type

1	2 position single solenoid
2	2 position double solenoid
3	3 position closed center
4	3 position exhaust center
5	3 position pressure center
A	4 position dual 3 port valve: N.C./N.C.
B	4 position dual 3 port valve: N.O./N.O.
C	4 position dual 3 port valve: N.C./N.O.

* 4 position dual 3 port valves are applicable to the 10-SV1000 and 10-SV2000 series only.

Pilot type

Nil	Internal pilot
R	External pilot

* External pilot specifications are not available for 4 position dual 3 port valves.

Manual override

Nil	Non-locking push type
D	Push-turn locking slotted type

Made to Order

Nil	—
X90	Main valve fluororubber (Refer to page 272.)

Light/surge voltage suppressor

U	With light/surge voltage suppressor
R	With surge voltage suppressor

Rated voltage

5	24 VDC
6	12 VDC

Back pressure check valve

Nil	None
K	Built-in

* The built-in back pressure check valve type is applicable to the 10-SV1000 series only.
 * The product with back pressure check valve is not available for 3 position solenoid valves.
 (Note) Refer to the Specific Product Precautions 2 on page 274.

Directional Control Valves
 Air Cylinders
 Rotary Actuators
 Air Grippers
 Air Preparation Equipment
 Modular F. R.
 Pressure Control Equipment
 Fittings & Tubing
 Flow Control Equipment
 Pressure Switches/ Pressure Sensors

Manifold Electrical Wiring

10F/16F D-sub connector type (25 pins)

· This circuit is for the double wiring specification with up to 11 stations. Since the usable number of solenoids differs depending on the manifold type, refer to the table below.
 For single solenoids, connect to SOL.A. Furthermore, when wiring is specified on the manifold specification sheet, connections are made without skipping any connectors, and signals A for single and A, B for double are in order 1→14→2→15, etc.
 · Stations are counted from the D side (connector side) as the 1st one.
 · Since solenoid valves do not have polarity, either the +COM or -COM can be use.

Usable No. of Solenoids

Model	Max. no. of solenoids
Type 10, Tie-rod base	23
10-SV1000 to 10-SV4000	18
Type 16, Cassette base	23
10-SV1000 to 10-SV2000	18

Dimensions: Series 10-SV1000 for D-sub Connector

• **Cassette base manifold: 10-SS5V1-16FD₂ - [Stations] ^U_D (R)-** C3, N1
C4, N3
C6, N7

• When P, E port outlets are indicated on the U side or D side, the P, E ports on the opposite side are plugged.
• External pilot port positions are the same as P, E port outlet positions.

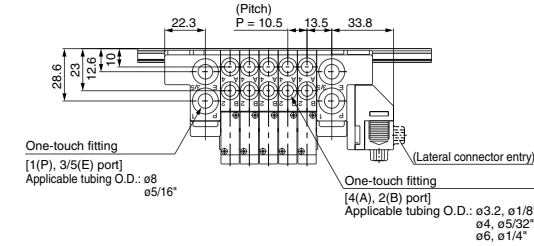

With external pilot specifications

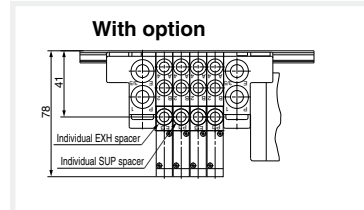
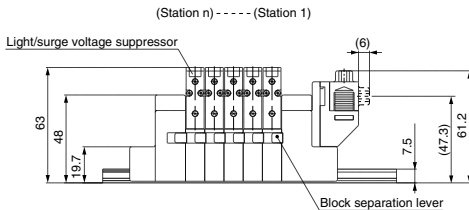
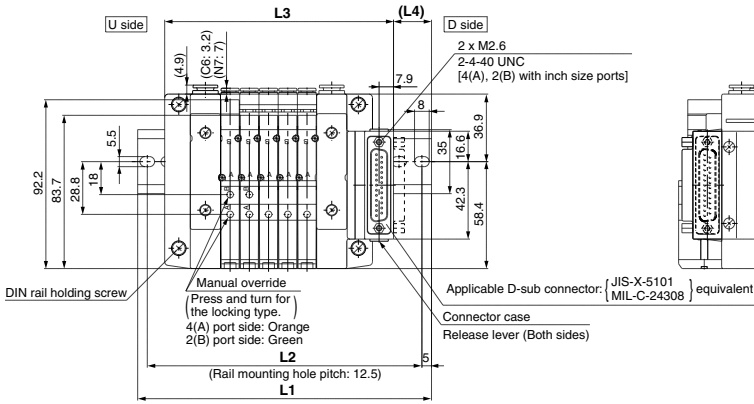
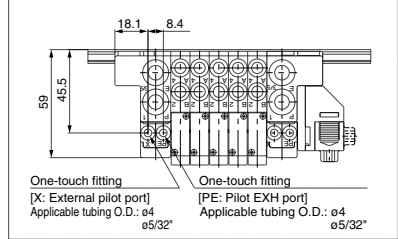

L Dimension

n	2	3	4	5	6	7	8	9	10	11	12	13	14	15	16	17	18
L1	123	135.5	148	160.5	173	185.5	198	198	210.5	223	235.5	248	260.5	260.5	273	285.5	298
L2	112.5	125	137.5	150	162.5	175	187.5	187.5	200	212.5	225	237.5	250	250	262.5	275	287.5
L3	93.5	104	114.5	125	135.5	146	156.5	167	177.5	188	198.5	209	219.5	230	240.5	251	261.5
L4	18	19	20	21	22	23	24	18.5	19.5	20.5	21.5	22.5	23.5	18.5	19.5	20.5	21.5

n: Stations

Directional Control Valves
 Air Cylinders
 Rotary Actuators
 Air Grippers
 Air Preparation Equipment
 Modular F. R.
 Pressure Control Equipment
 Fittings & Tubing
 Flow Control Equipment
 Pressure Switches/ Pressure Sensors

D-sub Connector 10-SV

Dimensions: Series 10-SV2000 for D-sub Connector

• Cassette base manifold: 10-SS5V2-16FD₂ - [Stations] $\frac{U}{D}$ (R) $\begin{matrix} C4, N3 \\ C6, N7 \\ C8, N9 \end{matrix}$

When P, E port outlets are indicated on the U side or D side, the P, E ports on the opposite side are plugged.
External pilot port positions are the same as P, E port outlet positions.

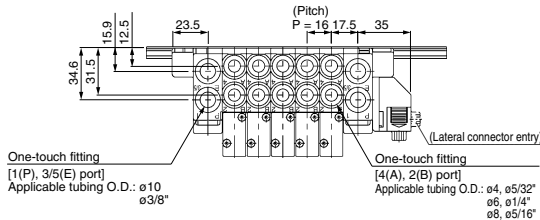

With external pilot specifications

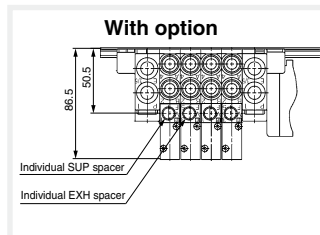
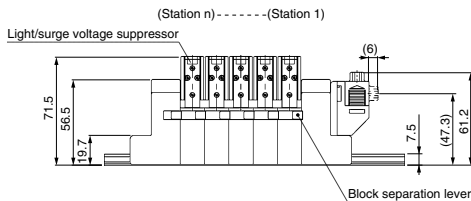
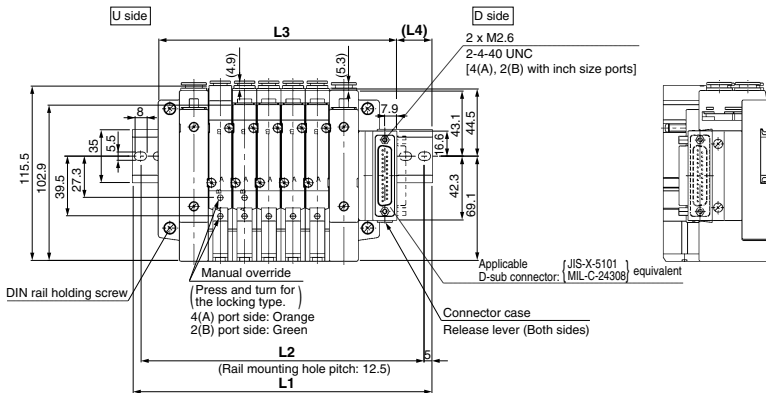
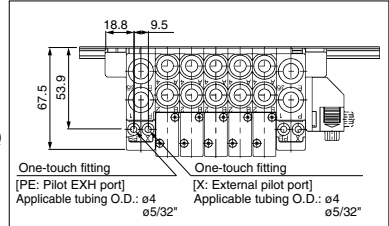

L Dimension

n	2	3	4	5	6	7	8	9	10	11	12	13	14	15	16	17	18	19	20
L1	148	160.5	173	198	210.5	223	235.5	260.5	273	285.5	310.5	323	335.5	348	373	385.5	398	423	435.5
L2	137.5	150	162.5	187.5	200	212.5	225	250	262.5	275	300	312.5	325	337.5	362.5	375	387.5	412.5	425
L3	109.5	125.5	141.5	157.5	173.5	189.5	205.5	221.5	237.5	253.5	269.5	285.5	301.5	317.5	333.5	349.5	365.5	381.5	397.5
L4	22.5	20.5	19	23.5	21.5	20	18	22.5	21	19	23.5	22	20	18.5	23	21	19.5	24	22

n: Stations

Dimensions: Series 10-SV1000 for D-sub Connector

• Tie-rod base manifold: 10-SS5V1-10FD₂ - [Stations] ^U_B (R)- C3, N1 C4, N3 C6, N7 (-D)

• When P, E port outlets are indicated on the U side or D side, the P, E ports on the opposite side are plugged.
 • External pilot port positions are the same as P, E port outlet positions.

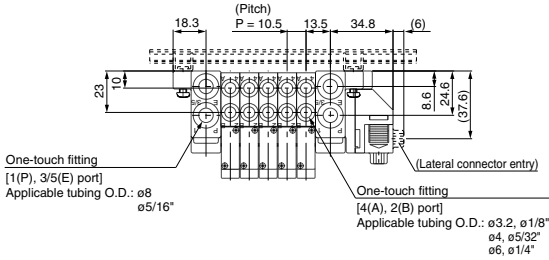

With external pilot specifications

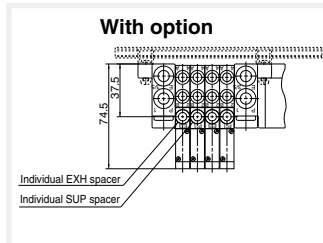
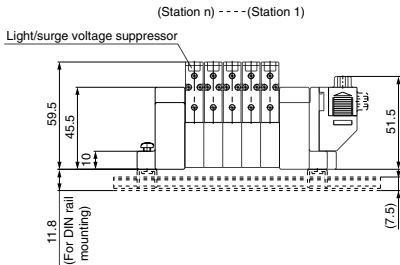
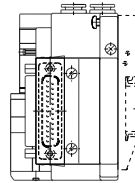
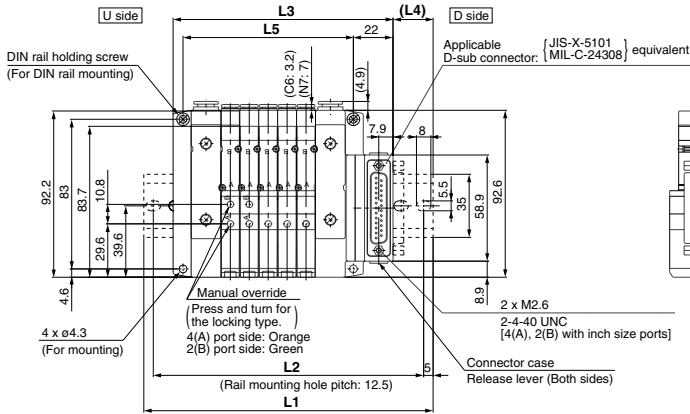
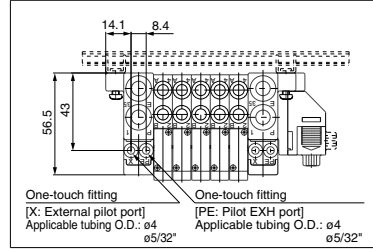

L Dimension

L	n	2	3	4	5	6	7	8	9	10	11	12	13	14	15	16	17	18	19	20
L1	123	135.5	148	160.5	173	173	185.5	198	210.5	223	235.5	235.5	248	260.5	273	285.5	298	310.5	310.5	
L2	112.5	125	137.5	150	162.5	162.5	175	187.5	200	212.5	225	225	237.5	250	262.5	275	287.5	300	300	
L3	90.5	101	111.5	122	132.5	143	153.5	164	174.5	185	195.5	206	216.5	227	237.5	248	258.5	269	279.5	
L4	19.5	20.5	21.5	22.5	23.5	18	19	20	21	22	23	18	19	20	21	22	23	24	18.5	
L5	63	73.5	84	94.5	105	115.5	126	136.5	147	157.5	168	178.9	189	199.5	210	220.5	231	241.5	252	

n: Stations

Directional Control Valves

Air Cylinders

Rotary Actuators

Air Grippers

Air Preparation Equipment

Modular F. R.

Pressure Control Equipment

Fittings & Tubing

Flow Control Equipment

Pressure Switches/ Pressure Sensors

Dimensions: Series 10-SV2000 for D-sub Connector

• Tie-rod base manifold: 10-SS5V2-10FD₂ - Stations U_D (R) - C4, N3, C6, N7, C8, N9 (-D)

When P, E port outlets are indicated on the U side or D side, the P, E ports on the opposite side are plugged.
 External pilot port positions are the same as P, E port outlet positions.

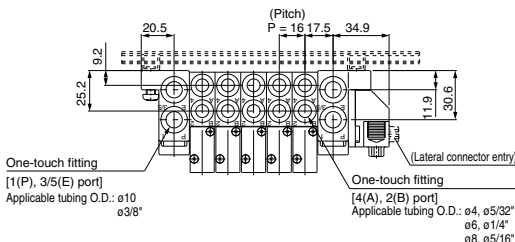

With external pilot specifications

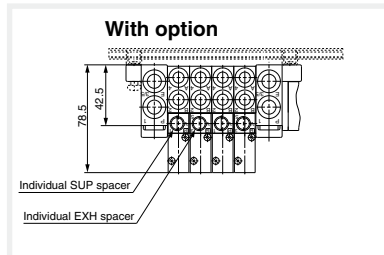
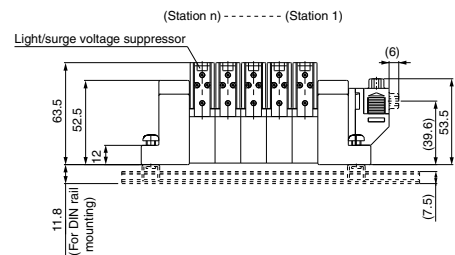
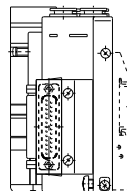
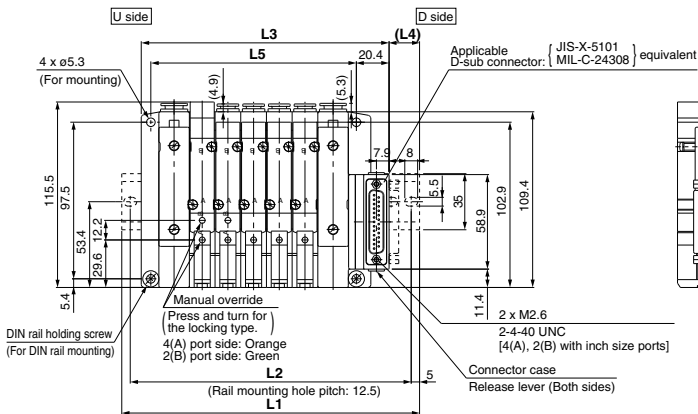
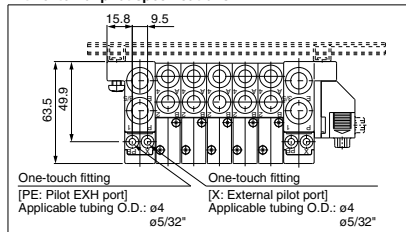

L Dimension

n	2	3	4	5	6	7	8	9	10	11	12	13	14	15	16	17	18	19	20
L1	135.5	160.5	173	185.5	210.5	223	235.5	248	273	285.5	298	323	335.5	348	360.5	385.5	398	410.5	435.5
L2	125	150	162.5	175	200	212.5	225	237.5	262.5	275	287.5	312.5	325	337.5	350	375	387.5	400	425
L3	106.4	122.4	138.4	154.4	170.4	186.4	202.4	218.4	234.4	250.4	266.4	282.4	298.4	314.4	330.4	346.4	362.4	378.4	394.4
L4	17.5	22	20.5	18.5	23	21.5	19.5	18	22.5	20.5	19	23.5	21.5	20	18	22.5	21	19	23.5
L5	80	96	112	128	144	160	176	192	208	224	240	256	272	288	304	320	336	352	368

Dimensions: Series 10-SV3000 for D-sub Connector

• Tie-rod base manifold: 10-SS5V3-10FD $\frac{1}{2}$ - [Stations] $\frac{U}{B}$ (R)- C6, N7
C8, N9 (-D) C10, N11

• When P, E port outlets are indicated on the U side or D side, the P, E ports on the opposite side are plugged.
• External pilot port positions are the same as P, E port outlet positions.

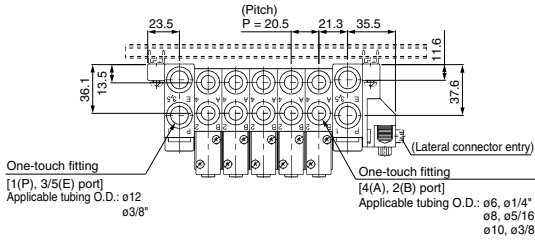

With external pilot specifications

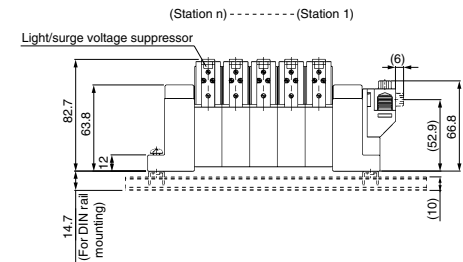
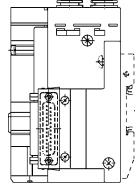
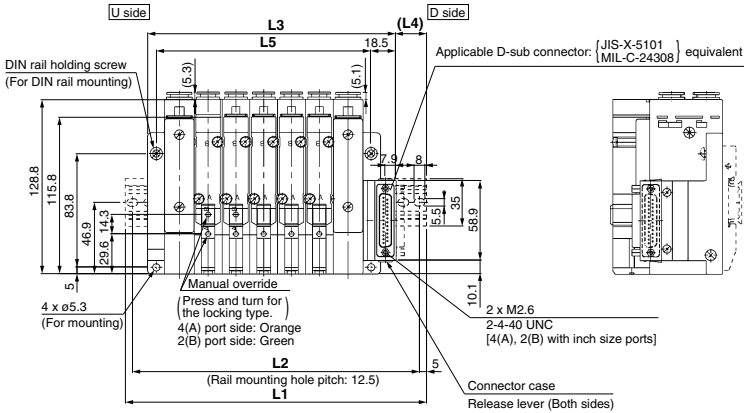
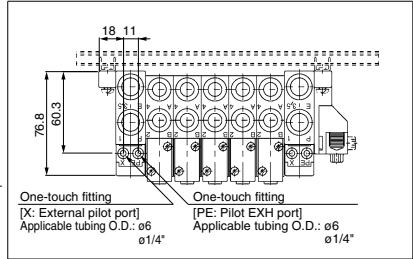

With option

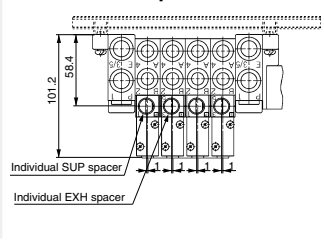

L Dimension

n	2	3	4	5	6	7	8	9	10	11	12	13	14	15	16	17	18	19	20
L1	160.5	173	198	223	235.5	260.5	285.5	298	323	348	360.5	385.5	398	423	448	460.5	485.5	510.5	523
L2	150	162.5	187.5	212.5	225	250	275	287.5	312.5	337.5	350	375	387.5	412.5	437.5	450	475	500	512.5
L3	122	142.5	163	183.5	204	224.5	245	265.5	286	306.5	327	347.5	368	388.5	409	429.5	450	470.5	491
L4	22.5	18.5	20.5	23	19	21	23.5	19.5	21.5	24	20	22	18	20.5	22.5	18.5	21	23	19
L5	97	117.5	138	158.5	179	199.5	220	240.5	261	281.5	302	322.5	343	363.5	384	404.5	425	445.5	466

Directional Control Valves
Air Cylinders
Rotary Actuators
Air Grippers
Air Preparation Equipment
Modular F. R.
Pressure Control Equipment
Fittings & Tubing
Flow Control Equipment
Pressure Switches/ Pressure Sensors

Dimensions: Series 10-SV4000 for D-sub Connector

• Tie-rod base manifold: 10-SS5V4-10FD₂ - Stations $\begin{matrix} U \\ D \end{matrix}$ (R)- $\begin{matrix} 02 \\ 03 \end{matrix}$ C₈, N₉ C₁₀, N₁₁ (-D)

• When P, E port outlets are indicated on the U side or D side, the P, E ports on the opposite side are plugged.
 • External pilot port positions are the same as P, E port outlet positions.

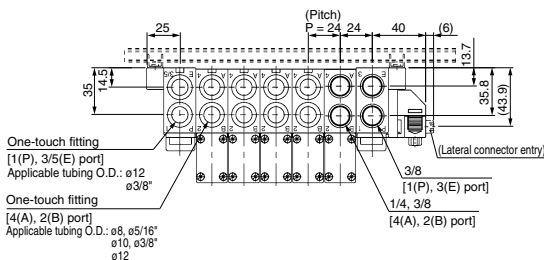

With external pilot specifications

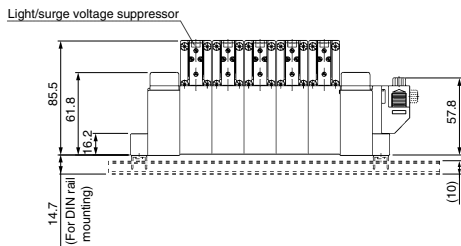
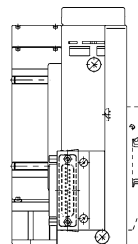
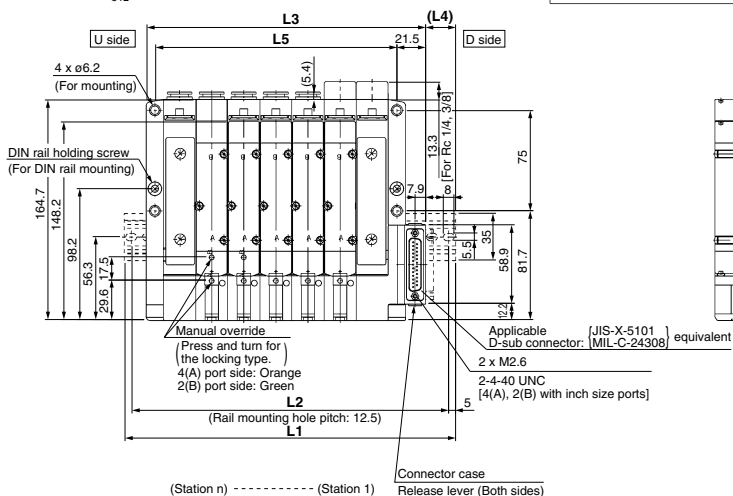
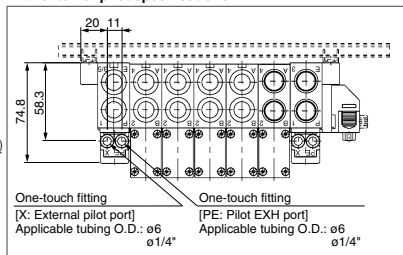

With option

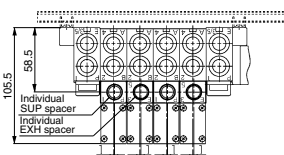

L Dimension

L _n	2	3	4	5	6	7	8	9	10	11	12	13	14	15	16	17	18	19	20
L1	173	198	223	248	273	298	310.5	335.5	360.5	385.5	410.5	435.5	460.5	485.5	510.5	535.5	560.5	585.5	610.5
L2	162.5	187.5	212.5	237.5	262.5	287.5	300	325	350	375	400	425	450	475	500	525	550	575	600
L3	137	161	185	209	233	257	281	305	329	353	377	401	425	449	473	497	521	545	569
L4	21	21.5	22	22.5	23	23.5	18	18.5	19	19.5	20	20.5	21	21.5	22	22.5	23	23.5	24
L5	109	133	157	181	205	229	253	277	301	325	349	373	397	421	445	469	493	517	541

n: Stations

Flat Ribbon Cable Connector

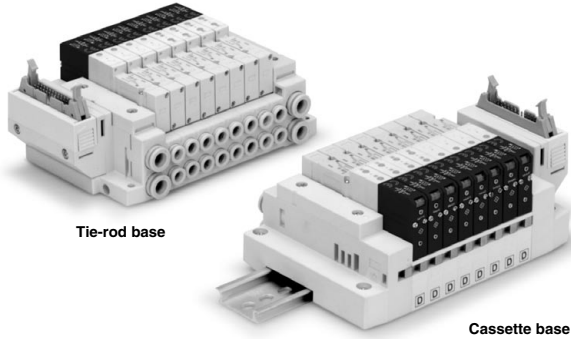

Tie-rod base

Cassette base

Applicable series	Cassette base manifold 10-SV1000/10-SV2000
	Tie-rod base manifold 10-SV1000/10-SV2000/10-SV3000/10-SV4000
<ul style="list-style-type: none"> · Number of connectors: 26, 20, 10 pins · With strain relief · Conforming to MIL-C-83503 	

Directional
Control Valves

Air Cylinders

Rotary Actuators

Air Grippers

Air Preparation
Equipment

Modular F. R.

Pressure Control
Equipment

Fittings & Tubing

Flow Control
Equipment

Pressure Switches/
Pressure Sensors

Series 10-SV

Flat Ribbon Cable Connector



How to Order

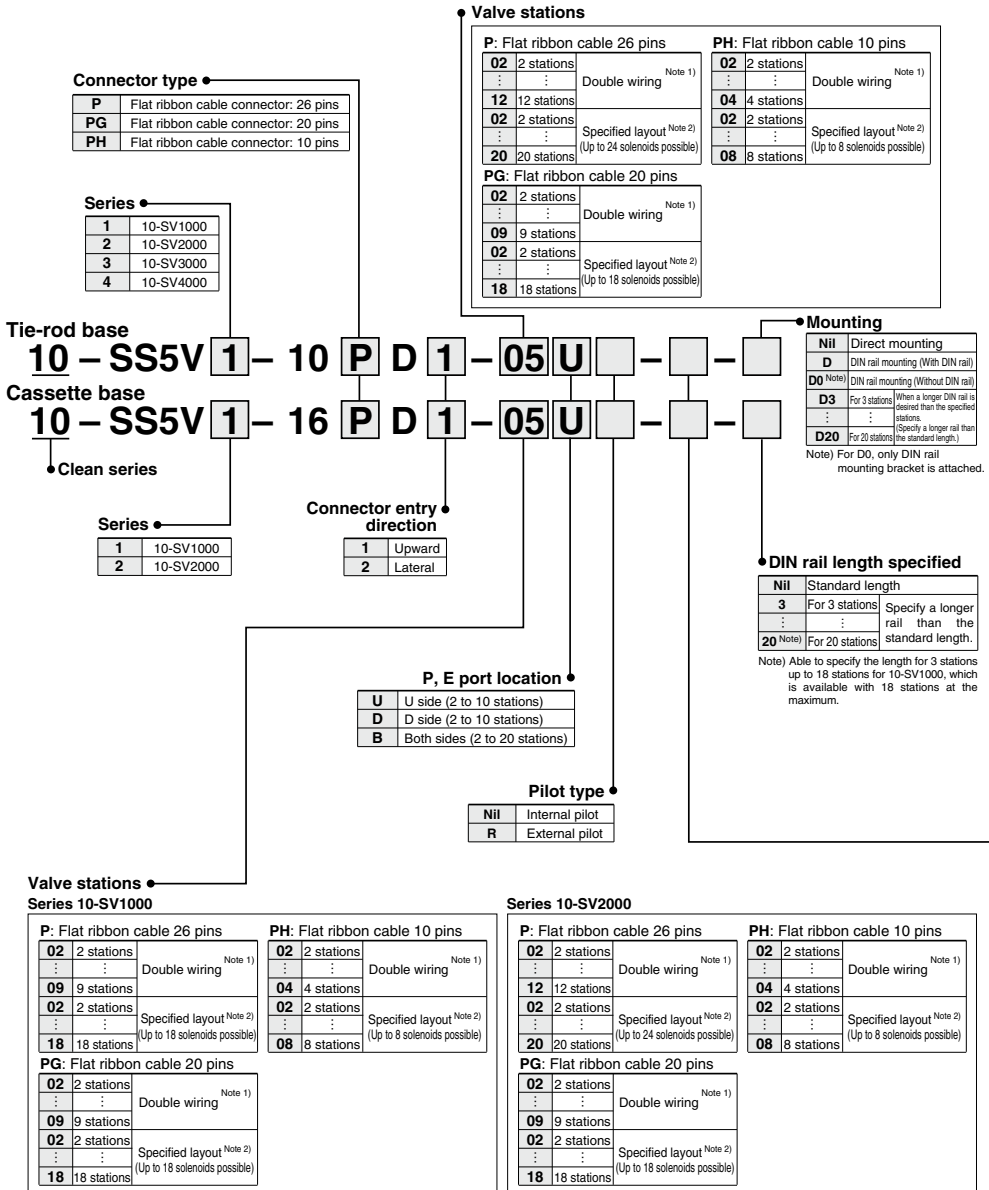

Note 1) Double wiring: Single, double, 3 position and 4 position solenoid valves can be used on all manifold stations. Use of a single solenoid will result in an unused control signal. If this is not desired, order with a specified layout.

Note 2) Specified layout: Indicate wiring specifications on the manifold specification sheet. (Note that double, 3 and 4 position valves cannot be used where single solenoid wiring has been specified.)

How to Order Valve Manifold Assembly

Ordering example (10-SV1000)

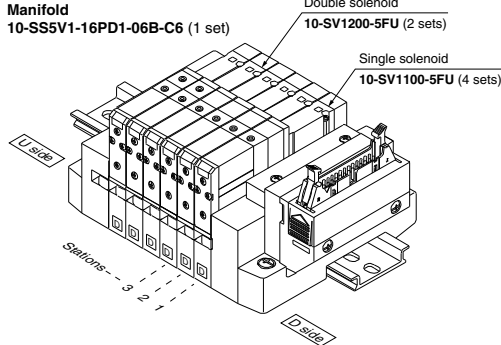

10-SS5V1-16PD1-06B-C6.....1 set (Manifold part no.)
 * 10-SV1100-5FU.....4 sets (Single solenoid part no.)
 * 10-SV1200-5FU.....2 sets (Double solenoid part no.)

How to Order Solenoid Valve

10 - SV 1 1 0 0 - **5 F** - (Note)

Clean series

Series

1	10-SV1000
2	10-SV2000
3	10-SV3000
4	10-SV4000

Actuation type

1	2 position single solenoid
2	2 position double solenoid
3	3 position closed center
4	3 position exhaust center
5	3 position pressure center
A	4 position dual 3 port valve: N.C./N.C.
B	4 position dual 3 port valve: N.O./N.O.
C	4 position dual 3 port valve: N.C./N.O.

* 4 position dual 3 port valves are applicable to the 10-SV1000 and 10-SV2000 series only.

Pilot type

Nil	Internal pilot
R	External pilot

* External pilot specifications are not available for 4 position dual 3 port valves.

Rated voltage

5	24 VDC
6	12 VDC

Back pressure check valve

Nil	None
K	Built-in

* The built-in back pressure check valve type is applicable to the 10-SV1000 series only.
 * The product with back pressure check valve is not available for 3 position solenoid valves.
 (Note) Refer to the Specific Product Precautions 2 on page 274.

(Note) Available with manifold block for station additions. Refer to the WEB catalog.

Made to Order

Nil	—
X90	Main valve fluororubber (Refer to page 272.)

Manual override

Nil: Non-locking push type

D: Push-turn locking slotted type

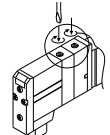
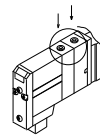

Light/surge voltage suppressor

U	With light/surge voltage suppressor
R	With surge voltage suppressor

A, B port size (Metric)

Symbol	A, B port	P, E port	Applicable series
C3	ø3.2 One-touch fitting	ø8 One-touch fitting	10-SV1000
C4	ø4 One-touch fitting		
C6	ø6 One-touch fitting		
C4	ø4 One-touch fitting	ø10 One-touch fitting	10-SV2000
C6	ø6 One-touch fitting		
C8	ø8 One-touch fitting		
C6	ø6 One-touch fitting	ø12 One-touch fitting	10-SV3000
C8	ø8 One-touch fitting		
C10	ø10 One-touch fitting		
C8	ø8 One-touch fitting	ø12 One-touch fitting	10-SV4000
C10	ø10 One-touch fitting		
C12	ø12 One-touch fitting		
O2	Rc 1/4	Rc 3/8	10-SV4000
O3	Rc 3/8		
O2F	G 1/4		
O3F	G 3/8	G 3/8	
M	Mixed		

A, B port size (Inch)

Symbol	A, B port	P, E port	Applicable series
N1	ø1/8" One-touch fitting	ø5/16" One-touch fitting	10-SV1000
N3	ø5/32" One-touch fitting		
N7	ø1/4" One-touch fitting		
N3	ø5/32" One-touch fitting	ø3/8" One-touch fitting	10-SV2000
N7	ø1/4" One-touch fitting		
N9	ø5/16" One-touch fitting		
N7	ø1/4" One-touch fitting	ø3/8" One-touch fitting	10-SV3000
N9	ø5/16" One-touch fitting		
N11	ø3/8" One-touch fitting		
N9	ø5/16" One-touch fitting	ø3/8" One-touch fitting	10-SV4000
N11	ø3/8" One-touch fitting		
O2N	NPT 1/4		
O3N	NPT 3/8	NPT 3/8	
O2T	NPTF 1/4	NPTF 3/8	
O3T	NPTF 3/8		
M	Mixed		

* For mixed specifications (M), indicate separately on the manifold specification sheet.

* External pilot type (R) X, PE port sizes are ø4 (metric), ø5/32" (inch) for the 10-SV1000/2000 series and ø6 (metric), ø1/4" (inch) for the 10-SV3000/4000 series.

Directional Control Valves
 Air Cylinders
 Rotary Actuators
 Air Grippers
 Air Preparation Equipment
 Modular F. R.
 Pressure Control Equipment
 Fittings & Tubing
 Flow Control Equipment
 Pressure Switches/Pressure Sensors

Manifold Electrical Wiring

10P/16P flat ribbon cable type (26 pins)

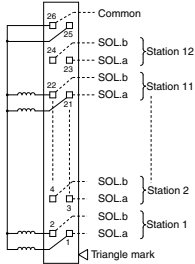

-This circuit is for the double wiring specification with up to 12 stations. Since the usable number of solenoids differs depending on the manifold type, refer to the table below. For single solenoids, connect to SOL.A. Furthermore, when wiring is specified on the manifold specification sheet, connections are made without skipping any connectors, and signals A for single and A, B for double are in order 1 → 2 → 3 → 4, etc.
 -Stations are counted from the D side (connector side) as the 1st one.
 -Since terminal numbers are not indicated on the flat ribbon cable, use the triangle mark as a reference for wiring.
 -Since solenoid valves do not have polarity, either the +COM or -COM can be used.

Usable no. of solenoids

Model	Max. no. of solenoids
Type 10, Tie-rod base	24
10-SV1000 to 10-SV4000	
Type 16, Cassette base	18
	10-SV1000 to 10-SV2000

10PG/16PG flat ribbon cable type (20 pins)

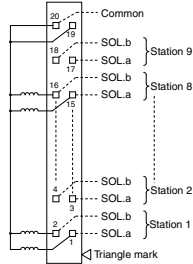

-This circuit is for the double wiring specification with up to 9 stations. Since the usable number of solenoids differs depending on the manifold type, refer to the table below. For single solenoids, connect to SOL.A. Furthermore, when wiring is specified on the manifold specification sheet, connections are made without skipping any connectors, and signals A for single and A, B for double are in order 1 → 2 → 3 → 4, etc.
 -Stations are counted from the D side (connector side) as the 1st one.
 -Since terminal numbers are not indicated on the flat ribbon cable, use the triangle mark as a reference for wiring.
 -Since solenoid valves do not have polarity, either the +COM or -COM can be used.

Usable no. of solenoids

Model	Max. no. of solenoids
Type 10, Tie-rod base	18
10-SV1000 to 10-SV4000	
Type 16, Cassette base	18
	10-SV1000 to 10-SV2000

10PH/16PH flat ribbon cable type (10 pins)

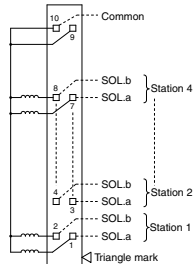

-This circuit is for the double wiring specification with up to 4 stations. Since the usable number of solenoids differs depending on the manifold type, refer to the table below. For single solenoids, connect to SOL.A. Furthermore, when wiring is specified on the manifold specification sheet, connections are made without skipping any connectors, and signals A for single and A, B for double are in order 1 → 2 → 3 → 4, etc.
 -Stations are counted from the D side (connector side) as the 1st one.
 -Since terminal numbers are not indicated on the flat ribbon cable, use the triangle mark as a reference for wiring.
 -Since solenoid valves do not have polarity, either the +COM or -COM can be used.

Usable no. of solenoids

Model	Max. no. of solenoids
Type 10, Tie-rod base	8
10-SV1000 to 10-SV4000	
Type 16, Cassette base	8
	10-SV1000 to 10-SV2000

Dimensions: Series 10-SV1000 for Flat Ribbon Cable

- **Cassette base manifold: 10-SS5V1-16^P_{PH} D₁ - [Stations] U_D (R) - C3, N1
C4, N3
C6, N7**

• When P, E port outlets are indicated on the U side or D side, the P, E ports on the opposite side are plugged.
• External pilot port positions are the same as P, E port outlet positions.

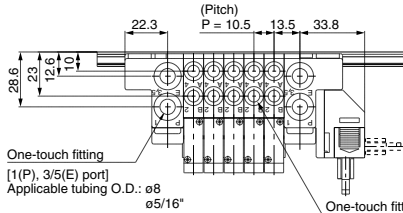

With external pilot specifications

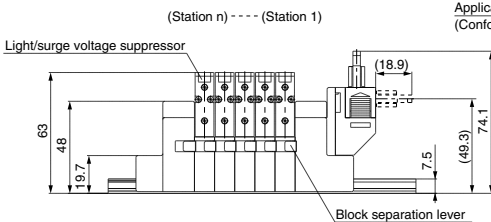
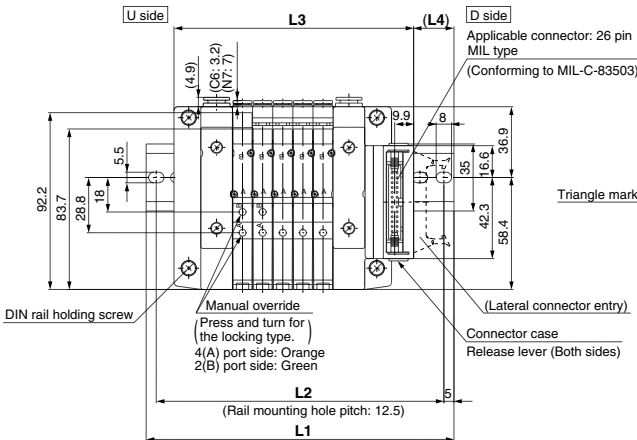
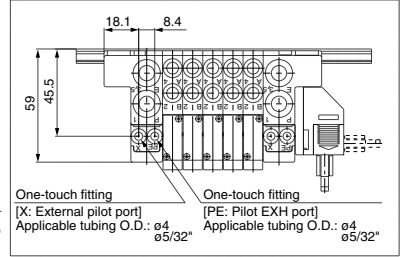

Applicable connector: 20 pin MIL type (Conforming to MIL-C-83503)

Applicable connector: 10 pin MIL type (Conforming to MIL-C-83503)

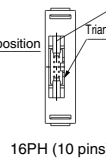
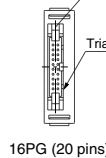

Refer to page 244 (for D-sub connector) for dimensions with individual SUP/EXH spacer.

L Dimension

n	2	3	4	5	6	7	8	9	10	11	12	13	14	15	16	17	18
L1	135.5	135.5	148	160.5	173	185.5	198	198	210.5	223	235.5	248	260.5	260.5	273	285.5	298
L2	125	125	137.5	150	162.5	175	187.5	187.5	200	212.5	225	237.5	250	250	262.5	275	287.5
L3	93.5	104	114.5	125	135.5	146	156.5	167	177.5	188	198.5	209	219.5	230	240.5	251	261.5
L4	24.5	19	20	21	22	23	24	19	20	21	22	23	24	18.5	19.5	20.5	21.5

n: Stations

Directional Control Valves

Air Cylinders

Rotary Actuators

Air Grippers

Air Preparation Equipment

Modular F. R.

Pressure Control Equipment

Fittings & Tubing

Flow Control Equipment

Pressure Switches/ Pressure Sensors

Dimensions: Series 10-SV2000 for Flat Ribbon Cable

- **Cassette base manifold: 10-SS5V2-16^P_{PG} D₁² - [Stations] U_D (R) - C4, N3
C6, N7
C8, N9**

When P, E port outlets are indicated on the U side or D side, the P, E ports on the opposite side are plugged.
External pilot port positions are the same as P, E port outlet positions.

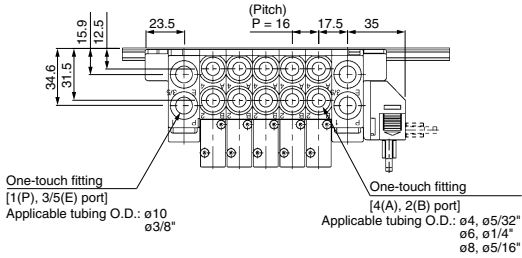

With external pilot specifications

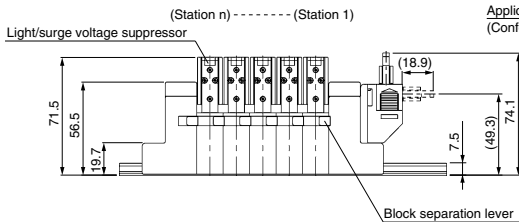
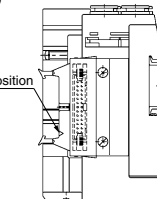
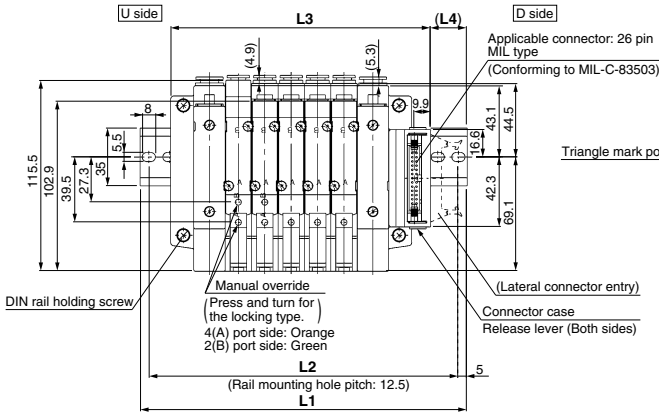
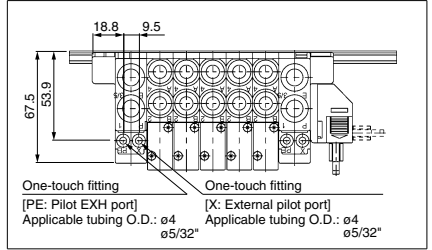

Applicable connector: 20 pin MIL type (Conforming to MIL-C-83503) Applicable connector: 10 pin MIL type (Conforming to MIL-C-83503)

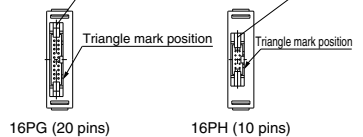

Refer to page 245 (for D-sub connector) for dimensions with individual SUP/EXH spacer.

L Dimension

n	2	3	4	5	6	7	8	9	10	11	12	13	14	15	16	17	18	19	20
L1	148	160.5	173	198	210.5	223	235.5	260.5	273	285.5	310.5	323	335.5	348	373	385.5	398	423	435.5
L2	137.5	150	162.5	187.5	200	212.5	225	250	262.5	275	300	312.5	325	337.5	362.5	375	387.5	412.5	425
L3	109.5	125.5	141.5	157.5	173.5	189.5	205.5	221.5	237.5	253.5	269.5	285.5	301.5	317.5	333.5	349.5	365.5	381.5	397.5
L4	22.5	21	19	23.5	22	20	18.5	23	21	19.5	24	22	20.5	18.5	23	21.5	19.5	24	22.5

Dimensions: Series 10-SV1000 for Flat Ribbon Cable

• Tie-rod base manifold: 10-SS5V1-10^P_{PH} D₂ - [Stations] ^U_B (R) - ^{C3, N1}_{C4, N3} ^{C6, N7} (-D)

When P, E port outlets are indicated on the U side or D side, the P, E ports on the opposite side are plugged.
 External pilot port positions are the same as P, E port outlet positions.

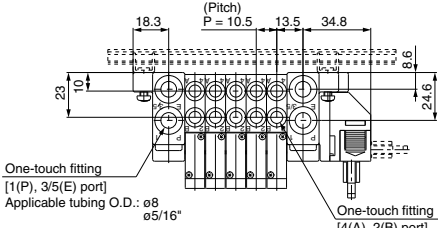

With external pilot specifications

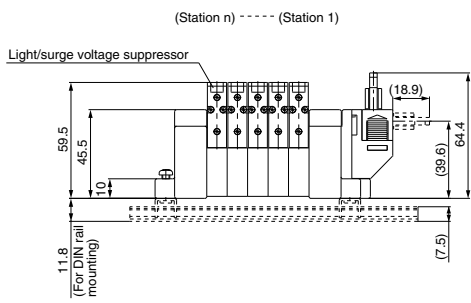
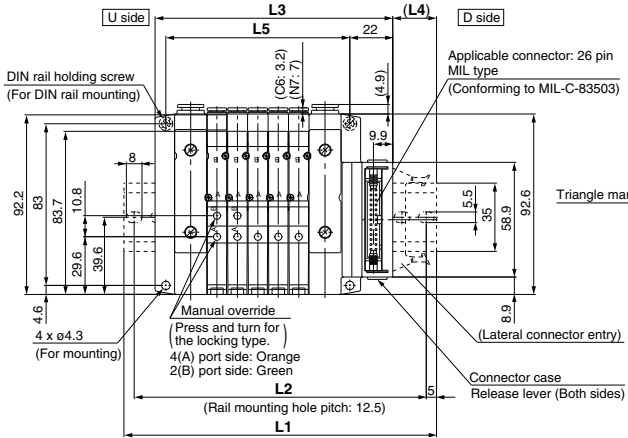
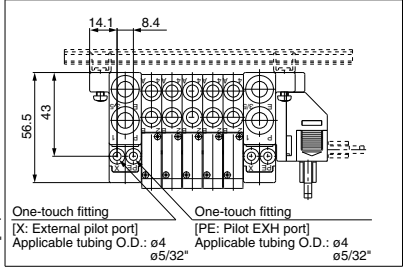

Applicable connector: 20 pin MIL type (Conforming to MIL-C-83503)

Applicable connector: 10 pin MIL type (Conforming to MIL-C-83503)

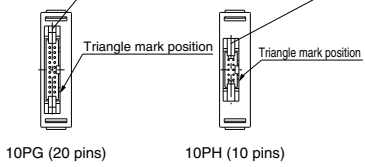

Refer to page 246 (for D-sub connector) for dimensions with individual SUP/EXH spacer.

L Dimension

n	2	3	4	5	6	7	8	9	10	11	12	13	14	15	16	17	18	19	20
L1	123	135.5	148	160.5	173	173	185.5	198	210.5	223	235.5	248	248	260.5	273	285.5	298	310.5	310.5
L2	112.5	125	137.5	150	162.5	162.5	175	187.5	200	212.5	225	237.5	237.5	250	262.5	275	287.5	300	300
L3	90.5	101	111.5	122	132.5	143	153.5	164	174.5	185	195.5	206	216.5	227	237.5	248	258.5	269	279.5
L4	19.5	20.5	21.5	22.5	23.5	18.5	19.5	20.5	21.5	22.5	23.5	24.5	19	20	21	22	23	24	19
L5	63	73.5	84	94.5	105	115.5	126	136.5	147	157.5	168	178.5	189	199.5	210	220.5	231	241.5	252

Directional Control Valves
 Air Cylinders
 Rotary Actuators
 Air Grippers
 Air Preparation Equipment
 Modular F. R.
 Pressure Control Equipment
 Fittings & Tubing
 Flow Control Equipment
 Pressure Switches/ Pressure Sensors

Dimensions: Series 10-SV2000 for Flat Ribbon Cable

• Tie-rod base manifold: 10-SS5V2-10^P_{PH} D₂ - (Stations) $\frac{U}{B}$ (R) - C4, N3
C6, N7 (N) C8, N9 (-D)

When P, E port outlets are indicated on the U side or D side, the P, E ports on the opposite side are plugged.
External pilot port positions are the same as P, E port outlet positions.

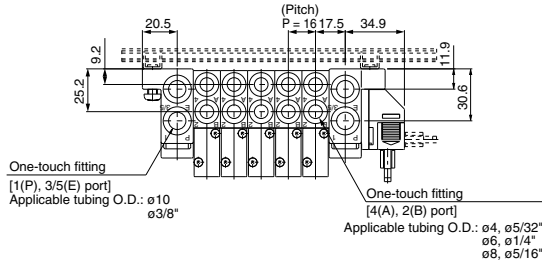

With external pilot specifications

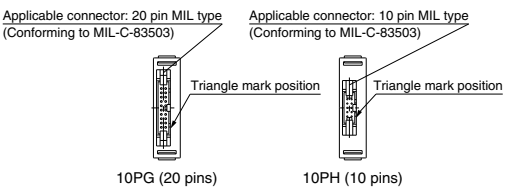
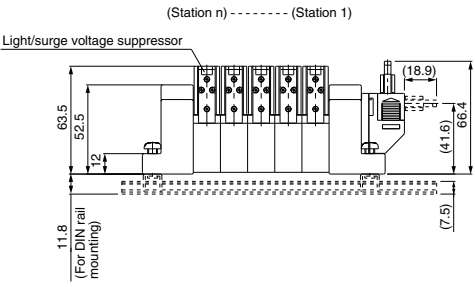
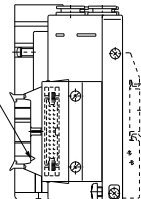
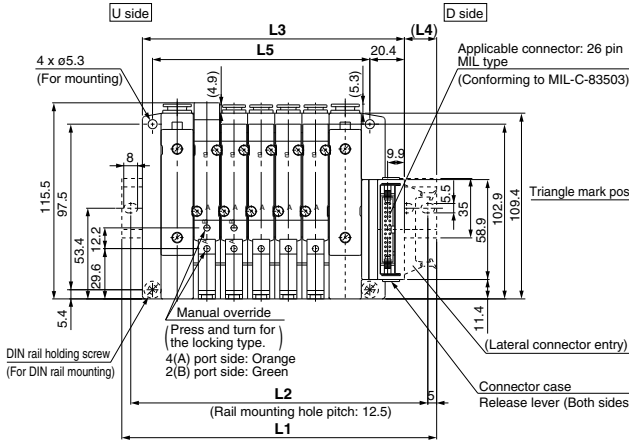
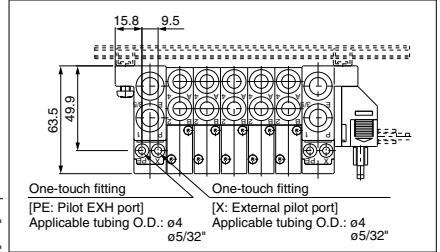

Refer to page 247 (for D-sub connector) for dimensions with individual SUP/EXH spacer.

L Dimension

n	2	3	4	5	6	7	8	9	10	11	12	13	14	15	16	17	18	19	20
L1	148	160.5	173	185.5	210.5	223	235.5	248	273	285.5	298	323	335.5	348	360.5	385.5	398	410.5	435.5
L2	137.5	150	162.5	175	200	212.5	225	237.5	262.5	275	287.5	312.5	325	337.5	350	375	387.5	400	425
L3	106.4	122.4	138.4	154.4	170.4	186.4	202.4	218.4	234.4	250.4	266.4	282.4	298.4	314.4	330.4	346.4	362.4	378.4	394.4
L4	24	22.5	20.5	19	23.5	21.5	20	18	22.5	21	19	23.5	22	20	18.5	23	21	19.5	24
L5	80	96	112	128	144	160	176	192	208	224	240	256	272	288	304	320	336	352	368

Dimensions: Series 10-SV3000 for Flat Ribbon Cable

• Tie-rod base manifold: 10-SS5V3-10^P_{PH} D₂- Stations^U_B (R) - C6, N7 C8, N9 C10, N11 (-D)

• When P, E port outlets are indicated on the U side or D side, the P, E ports on the opposite side are plugged.
 • External pilot port positions are the same as P, E port outlet positions.

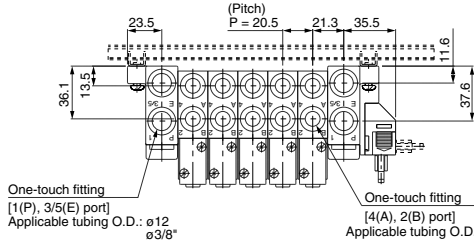

With external pilot specifications

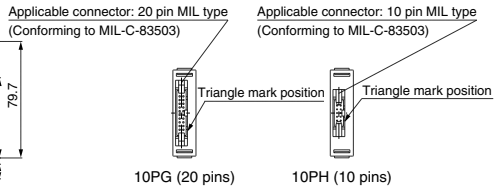
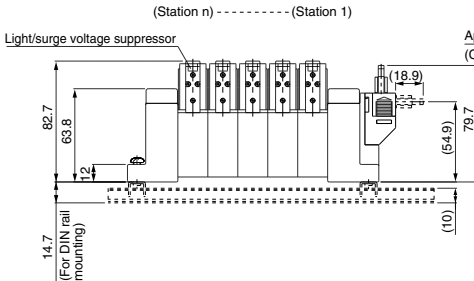
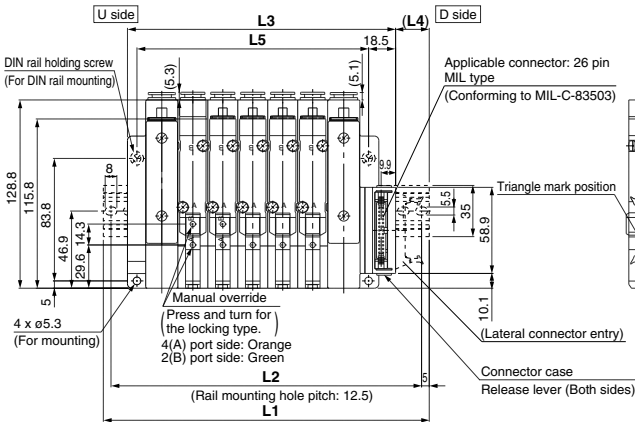
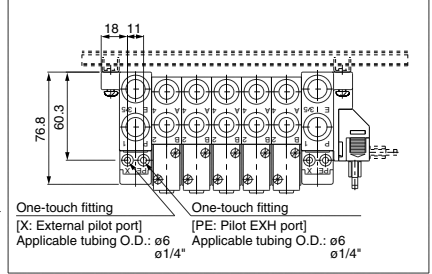

Refer to page 248 (for D-sub connector) for dimensions with individual SUP/EXH spacer.

L Dimension

n	2	3	4	5	6	7	8	9	10	11	12	13	14	15	16	17	18	19	20
L1	160.5	173	198	223	235.5	260.5	285.5	298	323	348	360.5	385.5	398	423	448	460.5	485.5	510.5	523
L2	150	162.5	187.5	212.5	225	250	275	287.5	312.5	337.5	350	375	387.5	412.5	437.5	450	475	500	512.5
L3	122	142.5	163	183.5	204	224.5	245	265.5	286	306.5	327	347.5	368	388.5	409	429.5	450	470.5	491
L4	22.5	18.5	21	23	19	21.5	23.5	19.5	22	24	20	22.5	18.5	20.5	23	19	21	23.5	19.5
L5	97	117.5	138	158.5	179	199.5	220	240.5	261	281.5	302	322.5	343	363.5	384	404.5	425	445.5	466

Directional Control Valves
 Air Cylinders
 Rotary Actuators
 Air Grippers
 Air Preparation Equipment
 Modular F. R.
 Pressure Control Equipment
 Fittings & Tubing
 Flow Control Equipment
 Pressure Switches/ Pressure Sensors

Dimensions: Series 10-SV4000 for Flat Ribbon Cable

• **Tie-rod base manifold: 10-SS5V4-10^P_{PG} D₂- [Stations] U_B (R) - 02^{C8}_{C10} 03^{N9}_{C12} N₁₁ (-D)**

When P, E port outlets are indicated on the U side or D side, the P, E ports on the opposite side are plugged.
 External pilot port positions are the same as P, E port outlet positions.

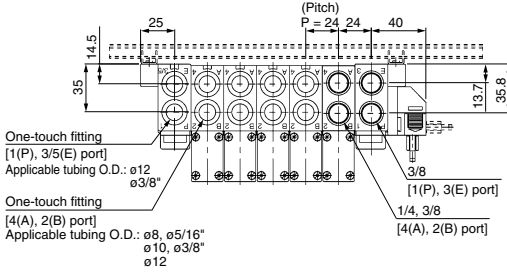

With external pilot specifications

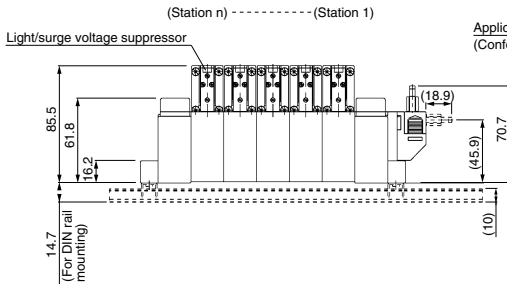
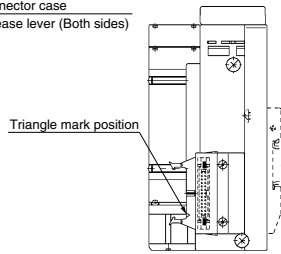
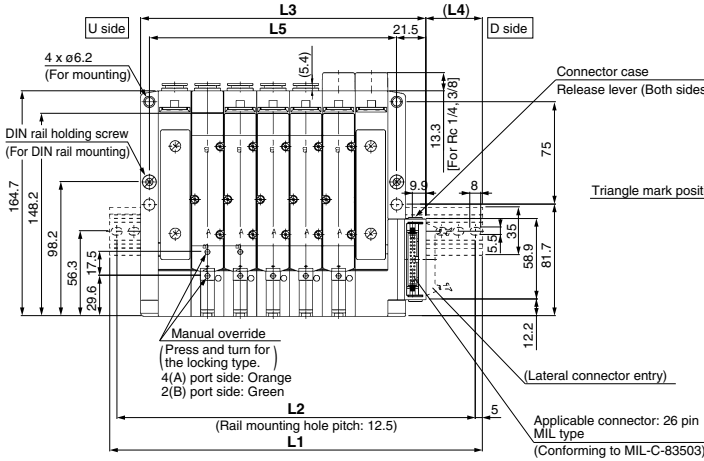
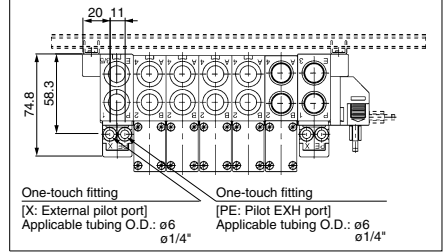

Applicable connector: 20 pin MIL type (Conforming to MIL-C-83503)

Applicable connector: 10 pin MIL type (Conforming to MIL-C-83503)

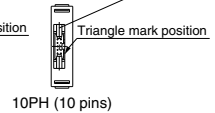
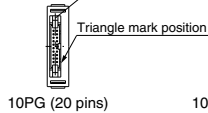

Refer to page 249 (for D-sub connector) for dimensions with individual SUP/EXH spacer.

L Dimension

L	n: Stations																			
	2	3	4	5	6	7	8	9	10	11	12	13	14	15	16	17	18	19	20	
L1	185.5	210.5	235.5	260.5	285.5	310.5	335.5	348	373	398	423	448	473	498	523	548	573	598	623	
L2	175	200	225	250	275	300	325	337.5	362.5	387.5	412.5	437.5	462.5	487.5	512.5	537.5	562.5	587.5	612.5	
L3	137	161	185	209	233	257	281	305	329	353	377	401	425	449	473	497	521	545	569	
L4	31.5	31.5	31.5	31.5	31.5	31.5	31.5	31.5	31.5	31.5	31.5	31.5	31.5	31.5	31.5	31.5	31.5	31.5	31.5	
L5	109	133	157	181	205	229	253	277	301	325	349	373	397	421	445	469	493	517	541	

Series 10-SV Manifold Option (Common for Type 16 and 10)

Relay output module

By adding a relay output module to the 10-SV series manifold, devices up to 110 VAC, 3 A (large type solenoid valves, etc.) can be controlled together with 10-SV series valves.

How to Order

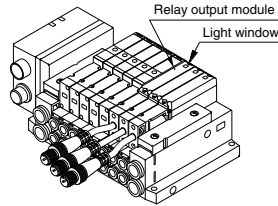
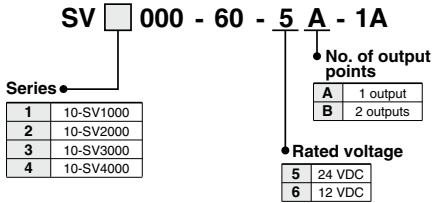

* Note that serial wiring manifolds (EX500, EX250 and EX120) are available with 24 VDC only.

Relay output module specifications

Item	Specifications			
No. of output points	1 output [connector with lead wire (M12)]		2 outputs [connector with lead wire (M12)]	
Output type	<p>Contact type ("a" contact)</p>		<p>Contact type ("a" contact)</p>	
Load voltage	110 VAC	30 VDC	110 VAC	30 VDC
Load current	3 A	3 A	0.3 A	1 A
Indicator light	Orange		A side: Orange B side: Green	
Enclosure	Based on IP67 (IEC60529)			
Current consumption	20 mA or less			
Polarity	Non-polar			
Weight (g)	48			

Y type connector

Used to branch a two output relay output module to two separate systems.

How to Order

EX500 - ACY00 - S

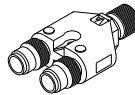

Relay output module and Y type connector wiring example

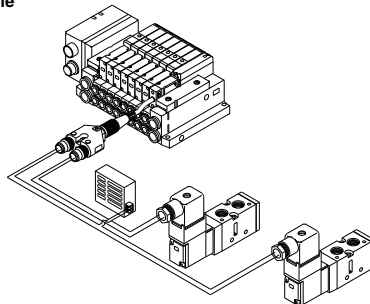
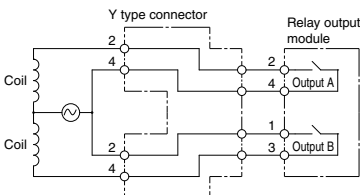

Manifold Option

■ Blanking plate assembly

Used in situations where valves will be added in the future.

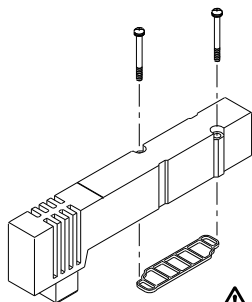

⚠ Caution

Mounting screw tightening torques

Series	Blanking plate assembly part no.
10-SV1000	SV1000-67-1A
10-SV2000	SV2000-67-1A
10-SV3000	SV3000-67-1A
10-SV4000	SV4000-67-1A

M2: 0.15 N·m

M3: 0.6 N·m

M4: 1.4 N·m

■ SUP/EXH block disk

[SUP block disk]

By placing a SUP block disk in a manifold valve's pressure supply passage, two different high and low pressures can be supplied to one manifold.

[EXH block disk]

By installing an EXH block disk in a manifold valve's exhaust passage, the valve's exhaust can be separated so that it will not affect other valves. It can also be used on a manifold with mixed positive pressure and vacuum. (Two pieces are required to block EXH on both sides. However, the 10-SV1000 and 2000 series type 10 manifolds require only one piece.)

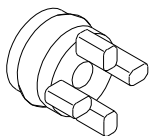

Type 16, Cassette base

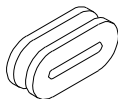

Type 10, Tie-rod base

Series	Manifold type	SUP block disk	EXH block disk
10-SV1000	10	SV1000-59-1A	SV1000-59-2A
	16	SX3000-77-1A	SX3000-77-1A
10-SV2000	10	SV2000-59-1A	SV2000-59-2A
	16	SV2000-59-3A	SV2000-59-3A
10-SV3000	10	SV3000-59-1A	SV3000-59-1A
10-SV4000	10	SY9000-57-1A	SY9000-57-1A

■ Label for block disk

These labels are attached to manifolds in which SUP and EXH block disks have been installed, in order to identify the installed locations. (Three sheets each included.)

SV1000 - 74 - 1A

Label for SUP block disk



Label for EXH block disk



Label for SUP/EXH block disk



* When a block disk is concurrently ordered by specifying on the manifold specification sheet, etc., a label will be stuck on the position where block disk is mounted.

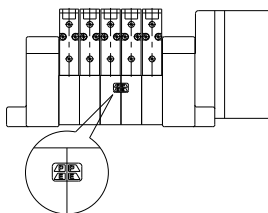

■ Plug (White)

These are inserted in unused cylinder ports and P, E ports.

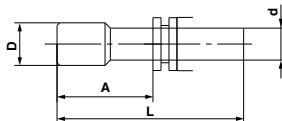

Applicable fitting size d	Model	A	L	D
$\phi 4$	10-KQP-04	16	32	$\phi 6$
$\phi 6$	10-KQP-06	18	35	$\phi 8$
$\phi 8$	10-KQP-08	20.5	39	$\phi 10$
$\phi 10$	10-KQP-10	22	43	$\phi 12$
$\phi 12$	10-KQP-12	24	44.5	$\phi 14$
$\phi 1/8"$	10-KQP-01	16	31.5	$\phi 5$
$\phi 5/32"$	10-KQP-03	16	32	$\phi 6$
$\phi 1/4"$	10-KQP-07	18	35	$\phi 8.5$
$\phi 5/16"$	10-KQP-09	20.5	39	$\phi 10$
$\phi 3/8"$	10-KQP-11	22	43	$\phi 11.5$

Manifold Option

■Circular connector / Cable assembly (26 pins)

AXT100 – MC26 – □

Lead wire length

Part no.	L dimension
AXT100-MC26-015	1.5 m
AXT100-MC26-030	3 m
AXT100-MC26-050	5 m

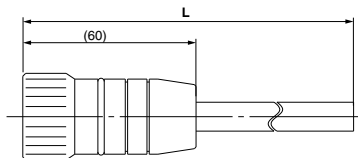

Plug terminal no.
(Arrangement as seen from lead wire side)

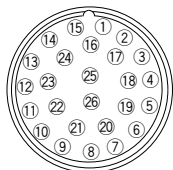

Circular connector cable assembly

Terminal no.

Terminal no.	Lead wire color	Dot marking
1	Black	None
2	Brown	None
3	Red	None
4	Orange	None
5	Yellow	None
6	Pink	None
7	Blue	None
8	Purple	White
9	Gray	Black
10	White	Black
11	White	Red
12	Yellow	Red
13	Orange	Red
14	Yellow	Black
15	Pink	Black
16	Blue	White
17	Purple	None
18	Gray	None
19	Orange	Black
20	Red	White
21	Brown	White
22	Pink	Red
23	Gray	Red
24	Black	White
25	White	None

Note) Terminal no. 26 is connected to 25 inside the connector.

■D-sub connector / Cable assembly (25 pins)

AXT100 – DS25 – □

Lead wire length

Part no.	L dimension
AXT100-DS25-015	1.5 m
AXT100-DS25-030	3 m
AXT100-DS25-050	5 m

When a commercially available connector is required, use a 25 pin female connector conforming to MIL-C-24308.

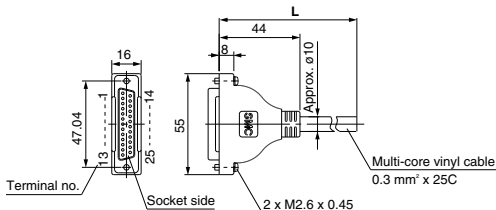

D-sub connector cable assembly

Terminal no.

Terminal no.	Lead wire color	Dot marking
1	Black	None
2	Brown	None
3	Red	None
4	Orange	None
5	Yellow	None
6	Pink	None
7	Blue	None
8	Purple	White
9	Gray	Black
10	White	Black
11	White	Red
12	Yellow	Red
13	Orange	Red
14	Yellow	Black
15	Pink	Black
16	Blue	White
17	Purple	None
18	Gray	None
19	Orange	Black
20	Red	White
21	Brown	White
22	Pink	Red
23	Gray	Red
24	Black	White
25	White	None

Circular connector, D-sub connector cable assembly

Electric characteristics

Item	Characteristics
Conductor resistance Ω/km, 20°C	65 or less
Withstand voltage VAC, 1 minute	1000
Insulation resistance MΩkm, 20°C	5 or less

Note) The minimum bending radius of each cable is 20 mm.

Manifold Option

■Flat ribbon cable / Cable assembly

AXT100 – FC□ – □

Cable length (L)	10 pins	20 pins	26 pins
1.5 m	AXT100-FC10-1	AXT100-FC20-1	AXT100-FC26-1
3 m	AXT100-FC10-2	AXT100-FC20-2	AXT100-FC26-2
5 m	AXT100-FC10-3	AXT100-FC20-3	AXT100-FC26-3
Connector width (W)	17.2	30	37.5

* For other commercial connectors, use a type with strain relief conforming to MIL-C-83503.

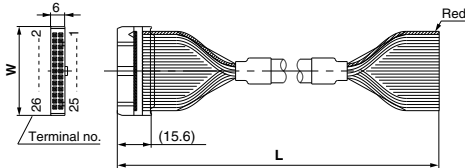

Example of connector manufacturers

- HIROSE ELECTRIC CO., LTD.
- Japan Aviation Electronics Industry, Limited
- 3M Japan Limited
- J.S.T. Mfg. Co., Ltd.
- Fujitsu Limited

■10-SV1000/2000 and EX500 series input unit

DIN rail dimensions and weights

VZ1000 – 11 – 1 – □

* As for □, enter the number from the DIN rail dimensions table.

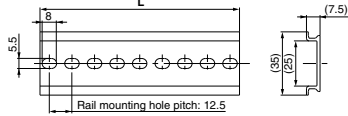

No.	0	1	2	3	4	5	6	7	8	9
L dimension	98	110.5	123	135.5	148	160.5	173	185.5	198	210.5
Weight (g)	17.6	19.9	22.1	24.4	26.6	28.9	31.1	33.4	35.6	37.9
No.	10	11	12	13	14	15	16	17	18	19
L dimension	223	235.5	248	260.5	273	285.5	298	310.5	323	335.5
Weight (g)	40.1	42.4	44.6	46.9	49.1	51.4	53.6	55.9	58.1	60.4
No.	20	21	22	23	24	25	26	27	28	29
L dimension	348	360.5	373	385.5	398	410.5	423	435.5	448	460.5
Weight (g)	62.5	64.9	67.1	69.4	71.6	73.9	76.1	78.4	80.6	82.9
No.	30	31	32	33	34	35	36	37	38	39
L dimension	473	485.5	498	510.5	523	535.5	548	560.5	573	585.5
Weight (g)	85.1	87.4	89.6	91.9	94.1	96.4	98.6	100.9	103.1	105.4
No.	40	41	42	43	44	45	46	47	48	49
L dimension	598	610.5	623	635.5	648	660.5	673	685.5	698	710.5
Weight (g)	107.6	109.9	112.1	114.4	116.6	118.9	121.1	123.4	125.6	127.9
No.	50	51	52	53	54	55	56	57	58	59
L dimension	723	735.5	748	760.5	773	785.5	798	810.5	823	835.5
Weight (g)	130.1	132.4	134.6	136.9	139.1	141.4	143.6	145.9	148.1	150.4
No.	60	61	62	63	64	65	66	67	68	69
L dimension	848	860.5	873	885.5	898	910.5	923	935.5	948	960.5
Weight (g)	152.6	154.9	157.1	159.4	161.6	163.9	166.1	168.4	170.6	172.9
No.	70	71								
L dimension	973	985.5								
Weight (g)	175.1	177.4								

■10-SV3000/4000 DIN rail dimensions and weights

VZ1000 – 11 – 4 – □

* As for □, enter the number from the DIN rail dimensions table.

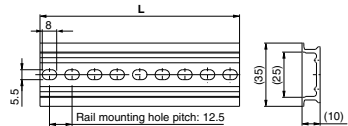

No.	0	1	2	3	4	5	6	7	8	9	10	11	12	13	14	15	16	17	18	19	20
L dimension	98	110.5	123	135.5	148	160.5	173	185.5	198	210.5	223	235.5	248	260.5	273	285.5	298	310.5	323	335.5	348
Weight (g)	24.8	28	31.1	34.3	37.4	40.6	43.8	46.9	50.1	53.3	56.4	59.6	62.7	65.9	69.1	72.2	75.4	78.6	81.7	84.9	88
No.	21	22	23	24	25	26	27	28	29	30	31	32	33	34	35	36	37	38	39	40	41
L dimension	360.5	373	385.5	398	410.5	423	435.5	448	460.5	473	485.5	498	510.5	523	535.5	548	560.5	573	585.5	598	610.5
Weight (g)	91.2	94.4	97.5	100.7	103.9	107	110.2	113.3	116.5	119.7	122.8	126	129.2	132.3	135.5	138.6	141.8	145	148.1	151.3	154.5
No.	42	43	44	45	46	47	48	49	50	51	52	53	54	55	56	57	58	59	60	61	62
L dimension	623	635.5	648	660.5	673	685.5	698	710.5	723	735.5	748	760.5	773	785.5	798	810.5	823	835.5	848	860.5	873
Weight (g)	157.6	160.8	163.9	167.1	170.3	173.4	176.6	179.8	182.9	186.1	189.2	192.4	195.6	198.7	201.9	205.1	208.2	211.4	214.5	217.7	220.9
No.	63	64	65	66	67	68	69	70	71												
L dimension	885.5	898	910.5	923	935.5	948	960.5	973	985.5												
Weight (g)	224	227.2	230.4	233.5	236.7	239.8	243	246.2	249.3												

Manifold Option

Individual SUP spacer assembly

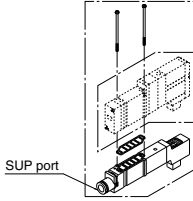

Individual EXH spacer assembly

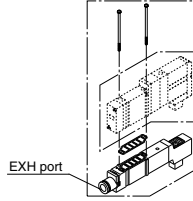

How to order individual SUP/EXH spacer assembly

Series 10-SV1000

SV1000 — **38** — **1A** — **C6**

• **Port size**

C3	ø3.2 One-touch fitting
C4	ø4 One-touch fitting
C6	ø6 One-touch fitting
N1	ø1/8" One-touch fitting
N3	ø5/32" One-touch fitting
N7	ø1/4" One-touch fitting

• **Spacer type**

38	Individual SUP spacer
39	Individual EXH spacer

Series 10-SV2000/10-SV3000/10-SV4000

SV **2 000** — **38** — **1** **A**

• **Series**

2	10-SV2000
3	10-SV3000
4	10-SV4000

• **Thread type** (Note)

Nil	Rc
F	G
N	NPT
T	NPTF

Note) 10-SV2000/3000/4000 port size

Series	Port size
10-SV2000	1/8
10-SV3000	1/4
10-SV4000	

Accessory

Series	Round head combination screw	Gasket
10-SV1000	SX3000-22-9 (M2 x 39.5)	SX3000-57-4
10-SV2000	SV2000-21-6 (M3 x 46)	SY5000-11-15
10-SV3000	SV3000-21-3 (M4 x 53)	SY7000-11-11
10-SV4000	SV2000-21-5 (M3 x 60)	SY9000-11-2

Directional Control Valves

Air Cylinders

Rotary Actuators

Air Grippers

Air Preparation Equipment

Modular F. R.

Pressure Control Equipment

Fittings & Tubing

Flow Control Equipment

Pressure Switches/ Pressure Sensors

Series 10-SV1000/2000/3000/4000

Single Unit/Sub-plate Type
[IP67 Compliant]

How to Order

10 - SV 1 1 00 - **5 W1 U D** - - -

Clean series •

Series •

1	10-SV1000
2	10-SV2000
3	10-SV3000
4	10-SV4000

Actuation type •

10-SV1000/2000/3000/4000	
1	2 position single (A)4 2(B) (EA)5 1 3(EB) (P)
2	2 position double (A)4 2(B) (EA)5 1 3(EB) (P)
10-SV1000/2000/3000	
3	3 position closed center (A)4 2(B) (EA)5 1 3(EB) (P)
4	3 position exhaust center (A)4 2(B) (EA)5 1 3(EB) (P)
5	3 position pressure center (A)4 2(B) (EA)5 1 3(EB) (P)
10-SV1000	
A	4 position dual 3 port valve: N.C./N.C. 4(A) 2(B) 5(EA) 1(P) 3(EB)
B	4 position dual 3 port valve: N.O./N.O. 4(A) 2(B) 5(EA) 1(P) 3(EB)
C	4 position dual 3 port valve: N.C./N.O. 4(A) 2(B) 5(EA) 1(P) 3(EB)

10-SV4000

3	3 position closed center (A)4 2(B) (EA)5 1 3(EB) (P)
4	3 position exhaust center (A)4 2(B) (EA)5 1 3(EB) (P)
5	3 position pressure center (A)4 2(B) (EA)5 1 3(EB) (P)
10-SV2000	
A	4 position dual 3 port valve: N.C./N.C. 4(A) 2(B) 5(EA) 1(P) 3(EB)
B	4 position dual 3 port valve: N.O./N.O. 4(A) 2(B) 5(EA) 1(P) 3(EB)
C	4 position dual 3 port valve: N.C./N.O. 4(A) 2(B) 5(EA) 1(P) 3(EB)

Pilot type •

Nil	Internal pilot
R	External pilot

* External pilot specifications are not available for 4 position dual 3 port valves.

Rated voltage •

5	24 VDC
6	12 VDC

Thread type

Nil	Rc
F	G
N	NPT
T	NPTF

Port size

Symbol	Port size	Applicable series
Nil	Without sub-plate	
01	1/8	10-SV1000
02	1/4	10-SV2000
03	3/8	10-SV3000
04	1/2	10-SV4000

Made to Order •

Nil	—
X90	Main valve fluororubber (Refer to page 272.)

Manual override

Nil	Non-locking push type
D	Push-turn locking slotted type

Light/Surge voltage suppressor

U	With light/surge voltage suppressor
R	With surge voltage suppressor

M12 waterproof connector

Symbol	Cable length (mm)
W1	300
W2	500
W3	1000
W4	2000
W7	5000

• 10-SV3000 and 4000 are not available with 4 position dual 3 port valves.

10-SV Series Solenoid Valve Specifications



Fluid		Air
Internal pilot operating pressure range (MPa)	2 position single	0.15 to 0.7
	4 position dual 3 port valve	
	2 position double	
External pilot operating pressure range (MPa)	3 position	-100 kPa to 0.7
	2 position single, double	
	3 position	
Ambient and fluid temperature (°C)		-10 to 50 (No freezing. Refer to page 680.)
Max. operating frequency (Hz)	2 position single, double	5
	4 position dual 3 port valve	
	3 position	3
Manual override		Non-locking push type Push-turn locking slotted type
Pilot exhaust method	Internal pilot	Main/Pilot valve common exhaust
	External pilot	Pilot valve individual exhaust
Lubrication		Not required
Mounting orientation		Unrestricted
Impact/Vibration resistance (m/s²)		150/30 (8.3 to 2000 Hz)
Enclosure		IP67 (Based on IEC60529)
Electrical entry		M12 waterproof connector
Coil rated voltage		24 VDC, 12 VDC
Allowable voltage fluctuation		±10% of rated voltage
Power consumption (W)		0.6 (With light: 0.65)
Surge voltage suppressor		Zener diode
Indicator light		LED

Note) Impact resistance: No malfunction occurred when it was tested with a drop tester in the axial direction and at right angles to the main valve and armature in both energized and deenergized states once for each condition. (Default settings)

Vibration resistance: No malfunction occurred in a one-sweep test between 45 and 2000 Hz. Test was performed in both energized and de-energized states in the axial direction and at right angles to the main valve and armature. (Default settings)

Response Time

Actuation type	Response time (ms) (at the pressure of 0.5 MPa)			
	10-SV1000	10-SV2000	10-SV3000	10-SV4000
2 position single	11 or less	25 or less	28 or less	40 or less
2 position double	10 or less	17 or less	26 or less	40 or less
3 position	18 or less	29 or less	32 or less	82 or less
4 position dual 3 port valve	15 or less	33 or less	—	—

Note) Based on dynamic performance test, JIS B 8375-1981. (Coil temperature: 20°C, at rated voltage)

M12 Waterproof Connector Wiring Specifications

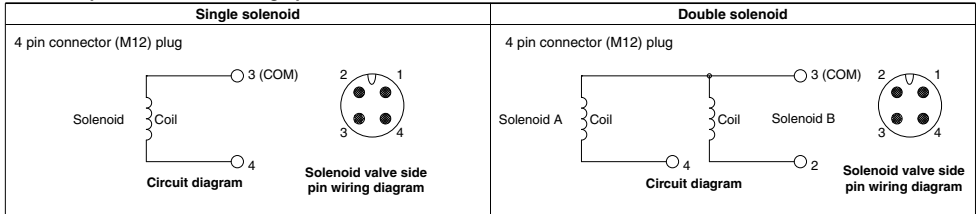

Note) Solenoid valves have no polarity.

Connection (Female Side) Connector Cable

As the parts are not supplied from SMC, refer to the application examples listed in the below. (For detail such as catalog availability, etc., please contact each manufacturer.)

Connector size	Number of pins	Manufacturer	Applicable series example
M12	4	Correns Corporation	VA-4D
		OMRON Corporation	XS2
		Azbil Corporation	PA5-41
		HIROSE ELECTRIC CO., LTD.	HR24
		DDK Ltd.	CM01-8DP4S

* This connector is a female connector for ① relay output module and ② single unit/sub-plate.

Single Unit/Sub-plate Type **10-SV**

Flow Rate Characteristics/Weight

10-SV1000

Valve model	Actuation type		Port size	Flow rate characteristics <small>Note 1)</small>						Weight (g) <small>Note 2)</small>	
				1 → 4/2 (P → A/B)			4/2 → 5/3 (A/B → EA/EB)			M12 waterproof connector (Cable length 300 mm)	
				C[dm ³ /(s·bar)]	b	Cv	C[dm ³ /(s·bar)]	b	Cv		
10-SV1□00-□-01□	2 position	Single	1/8	1.0	0.30	0.24	1.1	0.30	0.26	123 (88)	
		Double								128 (93)	
	3 position	Closed center		0.77	0.28	0.18	0.85	0.30	0.19	130 (95)	
		Exhaust center		1.2 [0.51]	0.24 [0.45]	0.29 [0.14]	0.89	0.47	0.24		
		Pressure center		0.68	0.35	0.18	1.1	0.39	0.29		
	4 position dual	N.C./N.C.		1/8	0.87	0.31	0.23	0.77	0.44	0.21	128 (93)
		N.O./N.O.									

Note 1) []: Denotes normal position. Note 2) (): Denotes without sub-plate.

10-SV2000

Valve model	Actuation type		Port size	Flow rate characteristics <small>Note 1)</small>						Weight (g) <small>Note 2)</small>	
				1 → 4/2 (P → A/B)			4/2 → 5/3 (A/B → EA/EB)			M12 waterproof connector (Cable length 300 mm)	
				C[dm ³ /(s·bar)]	b	Cv	C[dm ³ /(s·bar)]	b	Cv		
10-SV2□00-□-02□	2 position	Single	1/4	2.4	0.41	0.64	2.8	0.29	0.66	159 (96)	
		Double								163 (100)	
	3 position	Closed center		1.8	0.47	0.50	1.8	0.40	0.47	168 (105)	
		Exhaust center		3.3 [0.84]	0.36 [0.60]	0.85 [0.28]	3.0 [1.2]	0.33 [0.48]	0.72 [0.37]		
		Pressure center		2.2	0.40	0.55	2.6	0.31	0.60		
	4 position dual	N.C./N.C.		1/4	2.7	0.24	0.57	2.3	0.36	0.54	163 (100)
		N.O./N.O.									

Note 1) []: Denotes normal position. Note 2) (): Denotes without sub-plate.

10-SV3000

Valve model	Actuation type		Port size	Flow rate characteristics <small>Note 1)</small>						Weight (g) <small>Note 2)</small>
				1 → 4/2 (P → A/B)			4/2 → 5/3 (A/B → EA/EB)			M12 waterproof connector (Cable length 300 mm)
				C[dm ³ /(s·bar)]	b	Cv	C[dm ³ /(s·bar)]	b	Cv	
10-SV3□00-□-02□	2 position	Single	1/4	4.1	0.41	1.1	4.1	0.29	1.0	250 (121)
		Double								253 (124)
	3 position	Closed center		3.0	0.43	0.80	2.6	0.41	0.72	26 (132)
		Exhaust center		2.6	0.42	0.71	4.7 [1.7]	0.35 [0.48]	1.1 [0.49]	
		Pressure center		5.3 [2.3]	0.39 [0.49]	1.3 [0.65]	2.2	0.49	0.63	
10-SV3□00-□-03□	2 position	Single	3/8	4.9	0.29	1.2	4.5	0.27	1.1	235
		Double								238
	3 position	Closed center		3.0	0.40	0.80	2.6	0.45	0.73	246
		Exhaust center		2.6	0.42	0.71	4.8 [1.7]	0.35 [0.48]	1.1 [0.34]	
		Pressure center		5.3 [2.3]	0.31 [0.51]	1.3 [0.64]	2.3	0.45	0.66	

Note 1) []: Denotes normal position. Note 2) (): Denotes without sub-plate.

10-SV4000

Valve model	Actuation type		Port size	Flow rate characteristics <small>Note 1)</small>						Weight (g) <small>Note 2)</small>
				1 → 4/2 (P → A/B)			4/2 → 5/3 (A/B → EA/EB)			M12 waterproof connector (Cable length 300 mm)
				C[dm ³ /(s·bar)]	b	Cv	C[dm ³ /(s·bar)]	b	Cv	
10-SV4□00-□-03□	2 position	Single	3/8	7.9	0.34	2.0	9.6	0.43	2.5	505 (208)
		Double								509 (212)
	3 position	Closed center		7.5	0.33	1.8	7.3	0.30	1.7	530 (233)
		Exhaust center		7.2	0.34	1.7	13 [4.0]	0.23 [0.41]	2.8 [0.95]	
		Pressure center		12 [3.3]	0.26 [0.41]	2.8 [0.84]	6.7	0.40	1.9	
10-SV4□00-□-04□	2 position	Single	1/2	8.0	0.48	2.2	10	0.29	2.5	484
		Double								488
	3 position	Closed center		7.6	0.32	1.8	7.3	0.32	1.8	509
		Exhaust center		7.3	0.42	2.0	13 [4.7]	0.32 [0.54]	3.6 [1.5]	
		Pressure center		12 [3.3]	0.33 [0.51]	3.3 [0.94]	7.4	0.33	1.9	

Note 1) []: Denotes normal position. Note 2) (): Denotes without sub-plate.

Dimensions: Series 10-SV1000

2 position single/double, 4 position dual 3 port [M12 waterproof connector type]

10-SV1□00(R)-□W□□-01□

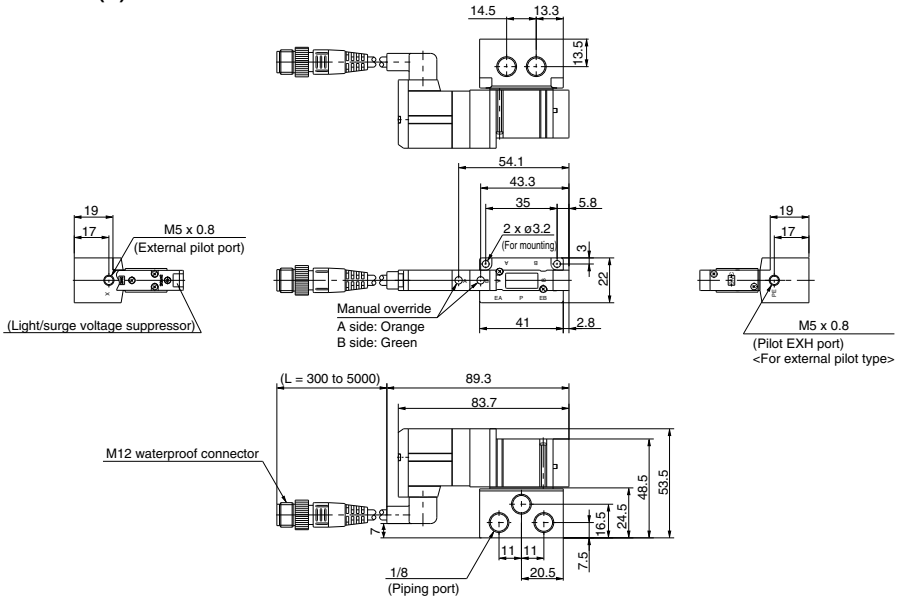

3 position closed center / exhaust center / pressure center [M12 waterproof connector type]

10-SV1□00(R)-□W□□-01□

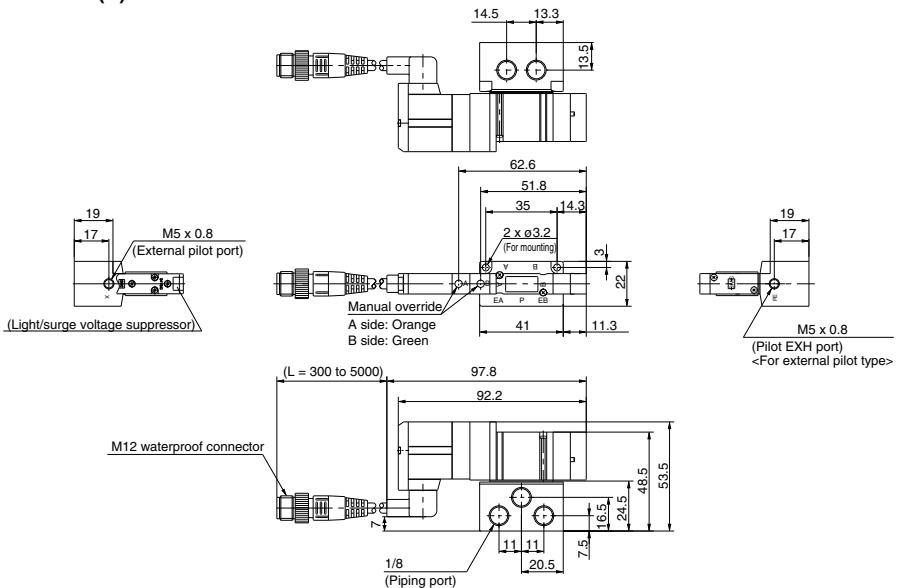

Directional Control Valves

Air Cylinders

Rotary Actuators

Air Grippers

Air Preparation Equipment

Modular F. R.

Pressure Control Equipment

Fittings & Tubing

Flow Control Equipment

Pressure Switches/ Pressure Sensors

Dimensions: Series 10-SV2000

2 position single/double, 4 position dual 3 port [M12 waterproof connector type]

10-SV2□00(R)-□W□□-02□

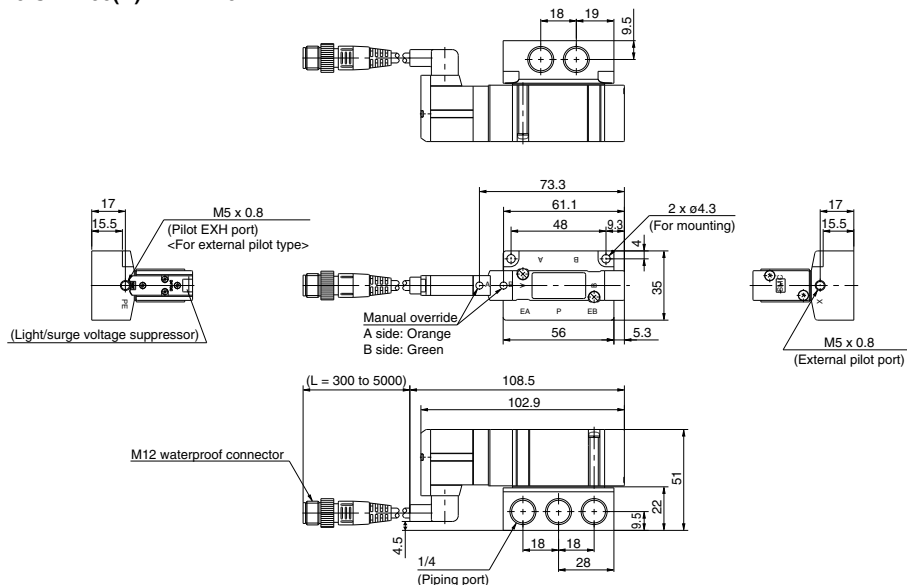

3 position closed center / exhaust center / pressure center [M12 waterproof connector type]

10-SV2□00(R)-□W□□-02□

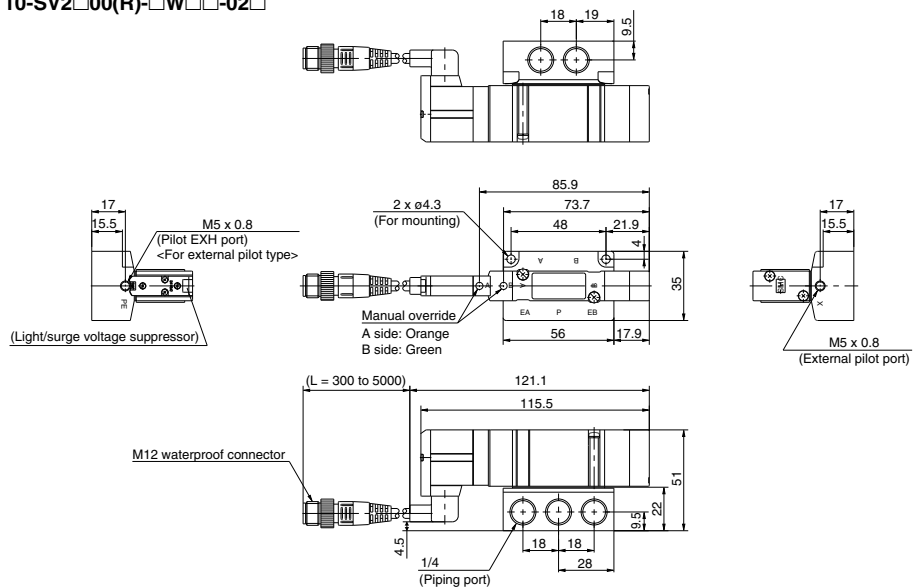

Dimensions: Series 10-SV3000

2 position single/double [M12 waterproof connector type]

10-SV3□00(R)-□W□□-02, 03□

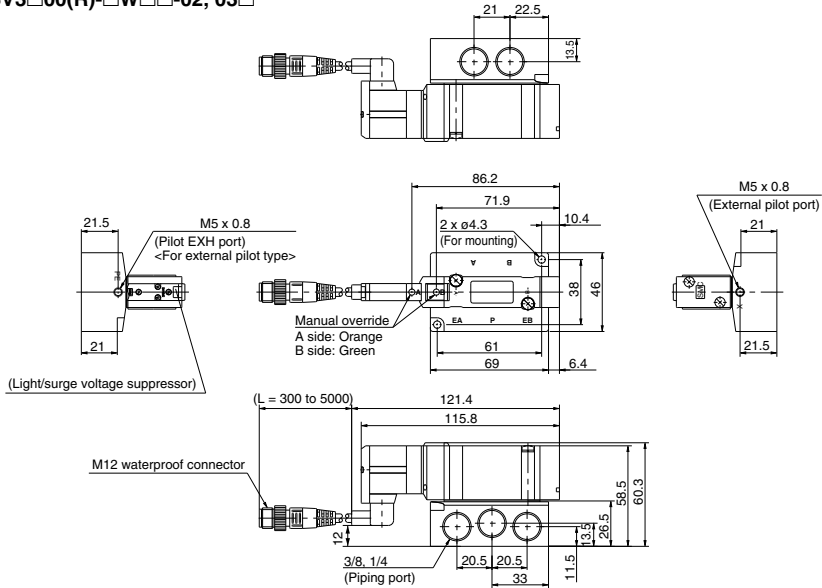

3 position closed center / exhaust center / pressure center [M12 waterproof connector type]

10-SV3□00(R)-□W□□-02, 03□

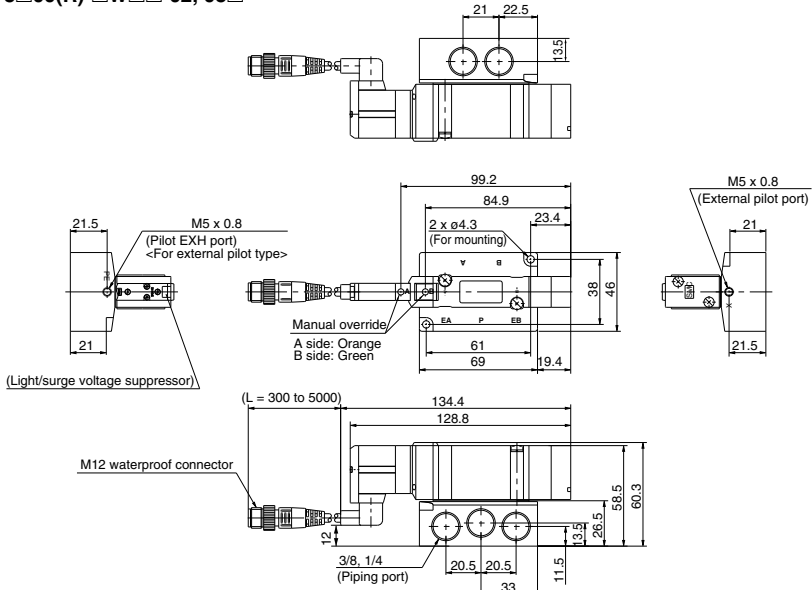

Directional Control Valves

Air Cylinders

Rotary Actuators

Air Grippers

Air Preparation Equipment

Modular F. R.

Pressure Control Equipment

Fittings & Tubing

Flow Control Equipment

Pressure Switches/ Pressure Sensors

Series 10-SV Made to Order

For detailed specifications, delivery and pricing, please contact SMC.

1 Main Valve Fluororubber Specifications Symbol -X90

Fluororubber is used for rubber parts of the main valve to allow use in applications such as the following.

1. When using a lubricant other than the recommended turbine oil, and there is a possibility of malfunction due to swelling of the spool valve seals.
2. When ozone enters or is generated in the air supply.

Part no.

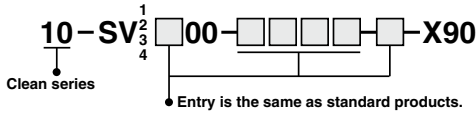

Note) Because in series -X90 fluororubber is used for only main valve, the rubber parts of the application/usage in conditions requiring heat resistance should be avoided.

Directional Control Valves

Air Cylinders

Rotary Actuators

Air Grippers

Air Preparation Equipment

Modular F. R.

Pressure Control Equipment

Fittings & Tubing

Flow Control Equipment

Pressure Switches/
Pressure Sensors

⚠ Specific Product Precautions 1

Be sure to read this before handling.

⚠ Warning

Operating Environment

1. Do not use valves in atmospheres of corrosive gases, chemicals, salt water, water, steam, or where there is direct contact with any of these.
2. Products compliant with IP65 and IP67 enclosures (Based on IEC529) are protected against dust and water, however, these products cannot be used in water.
3. Products compliant with IP65 and IP67 enclosures satisfy the specifications by mounting each product properly. Be sure to read the Specific Product Precautions for each product.

⚠ Warning

Manual Override Operation

Handle carefully, as connected equipment can be actuated through manual override operation.

■ Non-locking push type

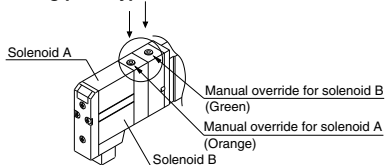

■ Push-turn locking slotted type

While pressing the lock down, turn it in the direction of the arrow. If it does not turn, it can be operated the same way as the non-locking type.

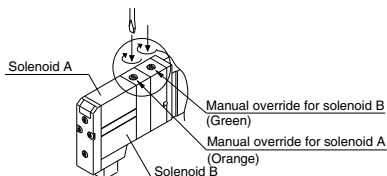

⚠ Caution

When locking the manual override with the push-turn locking slotted type, be sure to push the lock down before turning it. Turning without first pushing it down can cause damage to the manual override and other trouble such as air leakage, etc.

⚠ Caution

Exhaust Throttle

With the 10-SV series, pilot valve and main valve share a common exhaust inside the valve. Therefore, do not block the exhaust port when installing the piping.

⚠ Caution

Series 10-SV Used as a 3 Port Valve

When using a 5 port valve as a 3 port valve

The 10-SV series can be used as normally closed (N.C.) or normally open (N.O.) 3 port valves by closing one of the cylinder ports (A or B) with a plug. However, they should be used with the exhaust ports kept open. They are convenient at times when a double solenoid type 3 port valve is required.

Plug position		B port	A port
Actuation		N.C.	N.O.
Number of solenoids	Single		
	Double		

⚠ Caution

Light/Surge Voltage Suppressor

Solenoid valves have no polarity.

Light/Surge voltage suppressor

Single solenoid

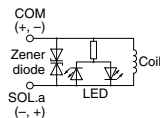

Double solenoid, 3 position type

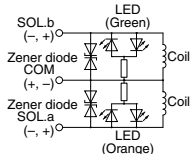

Surge voltage suppressor

Single solenoid

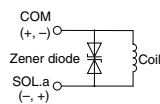

Double solenoid, 3 position type

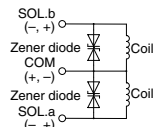

⚠ Caution

Light Indication

When equipped with light and surge voltage suppressor, the light window turns orange when solenoid A is energized, and it turns green when solenoid B is energized.

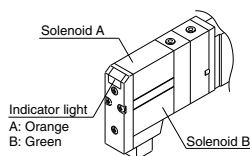

⚠ Specific Product Precautions 2

Be sure to read this before handling.

⚠ Caution

Valve Replacement, Adding/Removing Manifold Stations

Replacing solenoid valves and adding/removing manifold stations may cause external leakage. So, it is recommended to ask SMC for repair. When repair work is performed by the user, the user shall be responsible for the work since SMC cannot perform the inspection or check.

⚠ Caution

Connector Entry Directions

Connector entry directions for D-sub connectors and flat ribbon cables can be changed. To change the connector's entry direction, press the levers on both sides of the connector, take it off, and change the direction as shown in the drawing. Since lead wire assemblies are attached to the connector, excessive pulling or twisting can cause broken wires or other trouble. Also, take precautions so that lead wires are not caught and pinched when installing the connector.

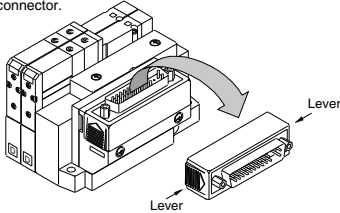

⚠ Caution

How to Order Manifold

The letter "S" or "D" is indicated on manifold blocks for the 10-SV series as shown below. This indication refers to the type of substrate assembly (single wiring or double wiring) inside the manifold blocks.

When the manifold specification sheet does not include wiring specifications, all stations will be double wiring specification (D). In this case, single and double solenoid valves can be mounted in any position, but when a single valve is used, there will be an unused control signal. To avoid this, indicate positions of manifold blocks for single wiring specification (S) and double wiring specification (D) on the manifold specification sheet. (Note that double, 3 or 4 position valves cannot be used for manifolds blocks with single wiring specification (S).)

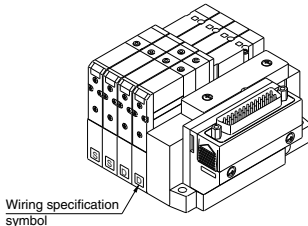

⚠ Caution

Substrate Assemblies inside Manifolds

Substrate assemblies inside of manifolds cannot be taken apart. Attempting to do so may damage parts.

⚠ Caution

One-touch Fittings

1. Tubing attachment/detachment for One-touch fittings

1) Attaching tubing

- Take a tubing with no flaws on its periphery and cut it off at a right angle. When cutting the tubing, use tube cutters TK-1, 2 or 3. Do not use pinchers, nippers or scissors, etc. If cutting is done with tools other than tube cutters, the tubing may be cut diagonally or become flattened, etc., making a secure installation impossible, and causing problems such as the tubing coming out after installation or air leakage.
Allow some extra length in the tubing.
- Grasp the tubing, slowly push it straight (0 to 5°) into the One-touch fitting until it comes to a stop.
- After inserting the tubing, pull on it lightly to confirm that it will not come out. If it is not installed securely all the way into the fitting, this can cause problems such as air leakage or the tubing coming out.

2) Detaching tubing

- Push in the release button sufficiently, pushing its collar equally around the circumference.
- Pull out the tubing while holding down the release button so that it does not come out. If the release button is not pressed down sufficiently, there will be increased bite on the tubing and it will become more difficult to pull it out.
- When the removed tubing is to be used again, cut off the portion which had been secured before reusing it. If the some portion of the tubing is reused, this can cause trouble such as air leakage or difficulty in removing the tubing.

⚠ Caution

Other Tubing Brands

1. When using tubing other than SMC brand tubing, confirm that the following specifications are satisfied with respect to the outside diameter tolerance of the tubing.

- Nylon tubing within ± 0.1 mm
- Soft nylon tubing within ± 0.1 mm
- Polyurethane tubing within $+0.15$ mm
within -0.2 mm

Do not use tubing which do not meet these outside diameter tolerances. It may not be possible to connect them, or they may cause other trouble, such as air leakage or the tubing coming out after connection.

⚠ Caution

Built-in Back Pressure Check Valve Type

- Valves with built-in back pressure check valve are to protect the back pressure inside a valve. For this reason, use caution the valves with external pilot specifications cannot be pressurized from exhaust port [3/5(E)]. As compared with the types which do not integrate the back pressure check valve, C value of the flow rate characteristics goes down. For details, please contact SMC.
- Do not switch valves when A or B port is open to the atmosphere, or while the actuators and air operated equipment are in operation. The back pressure prevention seal may be peeled off, which may cause air leakage or malfunctions. Use caution especially when performing a trial operation or maintenance work.

⚠ Specific Product Precautions 3

Be sure to read this before handling.

EX500/EX250/EX260/EX120

⚠ Warning

1. **These products are intended for use in general factory automation equipment.**
Avoid using these products in machinery/equipment which affects human safety, and in cases where malfunction or failure can result in extensive damage.
2. **Do not use in an explosive atmosphere, environment with inflammable gases, or corrosive atmosphere.**
This can cause injury or fire, etc.
3. **Work such as transporting, installing, piping, wiring, operation, control and maintenance should be performed by personnel with specialized knowledge.**
There is a danger of electrocution, injury or fire, etc.
4. **Install an external emergency stop circuit that can promptly stop operation and shut off the power supply.**
5. **Do not remodel these products, as there is a danger of injury and damage.**
6. **Do not wipe the product with chemicals, etc.**

⚠ Caution

1. **Read the operation manual carefully, strictly observe the precautions and operate within the range of the specifications.**
2. **Do not drop these products or submit them to strong impacts. This can cause damage, failure or malfunction, etc.**
3. **In locations with poor electrical conditions, take steps to ensure a steady flow of the rated power supply. Use of a voltage outside of the specifications can cause malfunction, damage to the unit, electrocution or fire, etc.**
4. **Do not touch connector terminals or internal substrates when current is being supplied. There is a danger of malfunction, damage to the unit or electrocution if connector terminals or internal substrates are touched when current is being supplied.**
Be sure that the power supply is OFF when adding or removing manifold valves or input blocks, etc., or when connecting or disconnecting connectors.
5. **Operate at an ambient temperature that is within the specifications. Even when the ambient temperature range is within the specifications, do not use in locations where there are rapid temperature changes.**
6. **Keep wire scraps and other extraneous material from getting inside these products. This can cause fire, failure or malfunction, etc.**
7. **Give consideration to the operating environment depending on the type of enclosure being used.**
To achieve IP65 or IP67 protection, provide appropriate wiring between all units using electrical wiring cables, communication connectors and cables with M12 connectors. Also, provide waterproof caps when there are unused ports, and perform proper mounting of input units, input blocks, SI units and manifold valves, etc. Provide a cover or other protection for applications in which there is constant exposure to water.
8. **Obey the proper tightening torque.**
There is a possibility of damaging threads if tightening exceeds the tightening torque range.
9. **Provide adequate protection when operating in locations such as the following:**
 - Where noise is generated by static electricity, etc.
 - Where there is a strong electric field
 - Where there is a danger of exposure to radiation
 - When in close proximity to power supply lines

⚠ Caution

10. **When these products are installed in equipment, provide adequate protection against noise by using noise filters, etc.**
11. **Since these products are components that are used after installation in other equipment, the customer should confirm conformity to EMC directives for the finished product.**
12. **Do not remove the name plate.**
13. **Perform periodic inspections and confirm normal operation. It may otherwise be impossible to guarantee safety due to unexpected malfunction or erroneous operation.**
14. **Do not use in places where there are cyclic temperature changes.**
In case that the cyclic temperature is beyond normal temperature changes, the inside the product is likely to be adversely affected.
15. **Do not use in direct sunlight.**
Do not use in direct sunlight. It may cause malfunction or damage.
16. **Do not use in places where there is radiated heat around it.**
Such a place is likely to cause malfunction.

Safety Instructions for Power Supply

⚠ Caution

1. **Operation is possible with a single power supply or a separate power supply. However, be sure to provide two wiring systems (one for solenoid valves, and one for input and control units).**
2. **Use the following UL approved products for DC power supply combinations.**
 - 1) **Controlled voltage current circuit conforming to UL508**
Circuit uses the secondary coil of an isolated transformer as the power supply, satisfying the following conditions.
 - Max. voltage (with no load): 30 Vrms (42.4 V peak) or less
 - Max. current: (1) 8 A or less (including shorts), and (2) When controlled by a circuit protector (fuse, etc.) with the following rating

No-load voltage (V peak)	Max. current rating
0 to 20 [V]	5.0
Over 20 [V] to 30 [V]	100
	Peak voltage value
 - 2) **A circuit (class 2 circuit) with maximum 30 Vrms (42.4 V peak) or less, and a power supply consisting of a class 2 power supply unit conforming to UL1310, or a class 2 transformer conforming to UL1585**

Safety Instructions for Cable

⚠ Caution

1. **Be careful of miswiring. This can cause malfunction, damage and fire in the unit.**
2. **To prevent noise and surge in signal lines, keep all wiring separate from power lines and high voltage lines. Otherwise, this can cause malfunction.**
3. **Check wiring insulation, as defective insulation can cause damage to the unit due to excessive voltage or current.**
4. **Do not bend or pull cables repeatedly, and do not place heavy objects on them or allow them to be pinched. This can cause broken lines.**

⚠ Specific Product Precautions 4

Be sure to read this before handling.

EX600

Design/Selection

⚠ Warning

- Use this product within the specification range.**
Using beyond the specified range can cause fire, malfunction, or damage to the system.
Confirm the specifications when operating.
- When using for an interlock circuit:**
 - Provide a multiple interlock system which is operated by another system (such as mechanical protection function).
 - Perform an inspection to check that it is working properly.

This may cause possible injury due to malfunction.

⚠ Caution

- When applicable to UL, use a Class 2 power supply unit conforming to UL1310 for direct current power supply.**
- Use this product within the specified voltage range.**
Using beyond the specified voltage range is likely to cause the units and connecting devices to be damaged or to malfunction.
- The power supply for the unit should be 0 V as the standard for both power supply for output as well as power supply for control/input.**

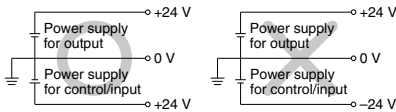

- Do not install a unit in a place where it can be used as a foothold.**
Applying any excessive load such as stepping on the unit by mistake or placing a foot on it, will cause it to break.
- Keep the surrounding space free for maintenance.**
When designing a system, take into consideration the amount of free space needed for performing maintenance.
- Do not remove the name plate.**
Improper maintenance or incorrect use of operation manual can cause failure and malfunction. Also, there is a risk of losing conformity with safety standards.
- Beware of inrush current when the power supply is turned on.**
Some connected loads can apply an initial charge current which will trigger the over current protection function, causing the unit to malfunction.

Mounting

⚠ Caution

- When handling and assembling units:**
 - Do not touch the sharp metal parts of the connector or plug.
 - Do not apply excessive force to the unit when disassembling.
The connecting portions of the unit are firmly joined with seals.
 - When joining units, take care not to get fingers caught between units.
Injury can result.
- Do not drop, bump, or apply excessive impact.**
Otherwise, the unit can become damaged, malfunction, or fail to function.
- Observe the tightening torque range.**
Tightening outside of the allowable torque range will likely damage the screw.
IP67 cannot be guaranteed if the screws are not tightened to the specified torque.
- When lifting a large size manifold solenoid valve unit, take care to avoid causing stress to the valve connection joint.**
The connection parts of the unit may be damaged.
Because the unit may be heavy, carrying and installation should be performed by more than one operator to avoid strain or injury.
- When placing a manifold, mount it on a flat surface.**
Torsion in the whole manifold can lead to trouble such as air leakage or defective insulation.

Wiring

⚠ Caution

- Confirm grounding to maintain the safety of the reduced wiring system and for anti-noise performance.**
Provide a specific grounding as close to the unit as possible to minimize the distance to grounding.
- Avoid repeatedly bending or stretching the cable and applying a heavy object or force to it.**
Wiring applying repeated bending and tensile stress to the cable can break the circuit.
- Avoid miswiring.**
If miswired, there is a danger of malfunction or damage to the reduced wiring system.
- Do not wire while energizing the product.**
There is a danger of malfunction or damage to the reduced wiring system or input/output equipment.
- Avoid wiring the power line and high pressure line in parallel.**
Noise or surge produced by signal line resulting from the power line or high pressure line could cause malfunction.
Wiring of the reduced wiring system or input/output device and the power line or high pressure line should be separated from each other.

Directional Control Valves

Air Cylinders

Rotary Actuators

Air Grippers

Air Preparation Equipment

Modular F. R.

Pressure Control Equipment

Fittings & Tubing

Flow Control Equipment

Pressure Switches/ Pressure Sensors

⚠ Specific Product Precautions 5

Be sure to read this before handling.

EX600

Wiring

⚠ Caution

6. Confirm the wiring insulation.

Defective insulation (contact with other circuits, improper insulation between terminals, etc.) may cause damage to the reduced wiring system or input/output device due to excessive voltage or current.

7. When a reduced wiring system is installed in machinery/equipment, provide adequate protection against noise by using noise filters, etc.

Noise in signal lines may cause malfunction.

8. When connecting wires of input/output device or Handheld Terminal, prevent water, solvent or oil from entering inside from the connector section.

This can cause damage, equipment failure or malfunction.

9. Avoid wiring patterns in which excessive stress is applied to the connector.

This may cause malfunction or damage to the unit due to contact failure.

Operating Environment

⚠ Warning

1. Do not use in an atmosphere containing an inflammable gas or explosive gas.

Use in such an atmosphere is likely to cause a fire or explosion. This system is not explosion-proof.

⚠ Caution

1. Select the proper type of enclosure according to the environment of operation.

IP65/67 is achieved when the following conditions are met.

1) Provide appropriate wiring between all units using electrical wiring cables, communication connectors and cables with M12 connectors.

2) Suitable mounting of each unit and manifold valve.

3) Be sure to mount a seal cap on any unused connectors.

If using in an environment that is exposed to water splashes, please take measures such as using a cover.

When the enclosure is IP40, do not use in an operating environment or atmosphere where it may come in contact with corrosive gas, chemical agents, seawater, water, or water vapor. When connected to EX600-D□□E or EX600-D□□F, manifold enclosure is IP40.

Also, the Handheld Terminal conforms to IP20, so prevent foreign matter from entering inside, and water, solvent or oil from coming in direct contact with it.

2. Provide adequate protection when operating in locations such as the following.

Failure to do so may cause damage or malfunction.

The effect of countermeasures should be checked in individual equipment and machine.

1) Where noise is generated by static electricity, etc.

2) Where there is a strong electric field

3) Where there is a danger of exposure to radiation

4) When in close proximity to power supply lines

Operating Environment

⚠ Caution

3. Do not use in an environment where oil and chemicals are used.

Operating in environments with coolants, cleaning solvents, various oils or chemicals may cause adverse effects (damage, malfunction) to the unit even in a short period of time.

4. Do not use in an environment where the product could be exposed to corrosive gas or liquid.

This may damage the unit and cause it to malfunction.

5. Do not use in locations with sources of surge generation.

Installation of the unit in an area around the equipment (electromagnetic lifters, high frequency induction furnaces, welding machine, motors, etc.), which generates the large surge voltage could cause to deteriorate an internal circuitry element of the unit or result in damage. Implement countermeasures against the surge from the generating source, and avoid touching the lines with each other.

6. Use the product type that has an integrated surge absorption element when directly driving a load which generates surge voltage by relay, solenoid valves or lamp.

When a surge generating load is directly driven, the unit may be damaged.

7. The product is CE marked, but not immune to lightning strikes. Take measures against lightning strikes in your system.

8. Keep dust, wire scraps and other extraneous material from getting inside the product.

This may cause malfunction or damage.

9. Mount the unit in such locations, where no vibration or shock is affected.

This may cause malfunction or damage.

10. Do not use in places where there are cyclic temperature changes.

In case that the cyclic temperature is beyond normal temperature changes, the internal unit is likely to be adversely effected.

11. Do not use in direct sunlight.

Do not use in direct sunlight. It may cause malfunction or damage.

12. Use this product within the specified ambient temperature range.

This may cause malfunction.

13. Do not use in places where there is radiated heat around it.

Such a place is likely to cause malfunction.

Adjustment/Operation

⚠ Warning

1. Do not perform operation or setting with wet hands.

There is a risk of electrical shock.

⚠ Specific Product Precautions 6

Be sure to read this before handling.

EX600

Adjustment/Operation

⚠ Warning

<Handheld Terminal>

- Do not apply pressure to the LCD.
There is a possibility of the crack of LCD and injuring.
- The forced input/output function is used to change the signal status forcibly. When operating this function, be sure to check the safety of the surroundings and installation.
Otherwise, injury or equipment damage could result.
- Incorrect setting of parameters can cause malfunction. Be sure to check the settings before use.
This may cause injury or equipment damage.

⚠ Caution

- Use a watchmaker's screwdriver with thin blade for the setting of each switch of the SI Unit.
When setting the switch, do not touch other unrelated parts.
This may cause parts damage or malfunction due to a short circuit.
- Provide adequate setting for the operating conditions.
Failure to do so could result in malfunction.
Refer to the operation manual for setting of the switches.
- For the details of programming and address setting, refer to the manual from the PLC manufacturer.
The content of programming related to protocol is designed by the manufacturer of the PLC used.

<Handheld Terminal>

- Do not press the setting buttons with a sharp pointed object.
This may cause damage or malfunction.
- Do not apply excessive load and impact to the setting buttons.
This may cause damage, equipment failure or malfunction.

When the order does not include the SI Unit, the valve plate to connect the manifold and SI Unit is not mounted. Use attached valve holding screws and mount the valve plate.
(Tightening torque: 0.6 to 0.7 N·m)

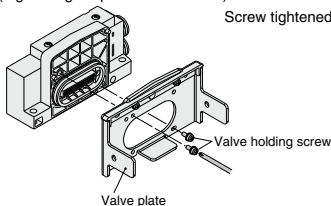

Maintenance

⚠ Warning

- Do not disassemble, modify (including circuit board replacement) or repair this product.
Such actions are likely to cause injuries or breakage.
- When an inspection is performed,
 - Turn off the power supply.
 - Stop the air supply, exhaust the residual pressure in piping and verify that the air is released before performing maintenance work.
Unexpected malfunction of system components and injury can result.

⚠ Caution

- When handling and replacing the unit:
 - Do not touch the sharp metal parts of the connector or plug.
 - Do not apply excessive force to the unit when disassembling.
The connecting portions of the unit are firmly joined with seals.
 - When joining units, take care not to get fingers caught between units.
Injury can result.
- Perform periodic inspection.
Unexpected malfunction in the system composition devices is likely to occur due to malfunction of machinery or equipment.
- After maintenance, make sure to perform an appropriate functionality inspection.
In cases of abnormality such as faulty operation, stop operation. Unexpected malfunction in the system composition devices is likely to occur.
- Do not use benzene and thinner for cleaning units.
Damage to the surface or erasure of the display can result. Wipe off any stains with a soft cloth.
If the stain is persistent, wipe off with a cloth soaked in a dilute solution of neutral detergent and wrung out tightly, and then finish with a dry cloth.

Other

⚠ Caution

- Refer to the catalog of each series for Common Precautions and Specific Product Precautions on manifold solenoid valves.

■ Trademark

DeviceNet™ is a trademark of ODVA. EtherNet/IP™ is a trademark of ODVA. CompoNet™ is a trademark of ODVA. EtherCAT® is registered trademark and patented technology, licensed by Beckhoff Automation GmbH, Germany.