

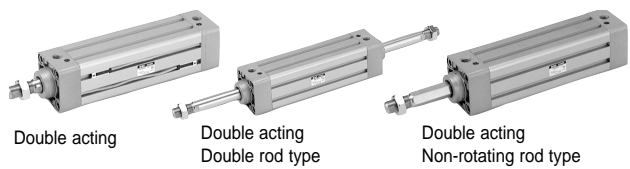

**Profile Design ISO/VDMA
Air Cylinder**

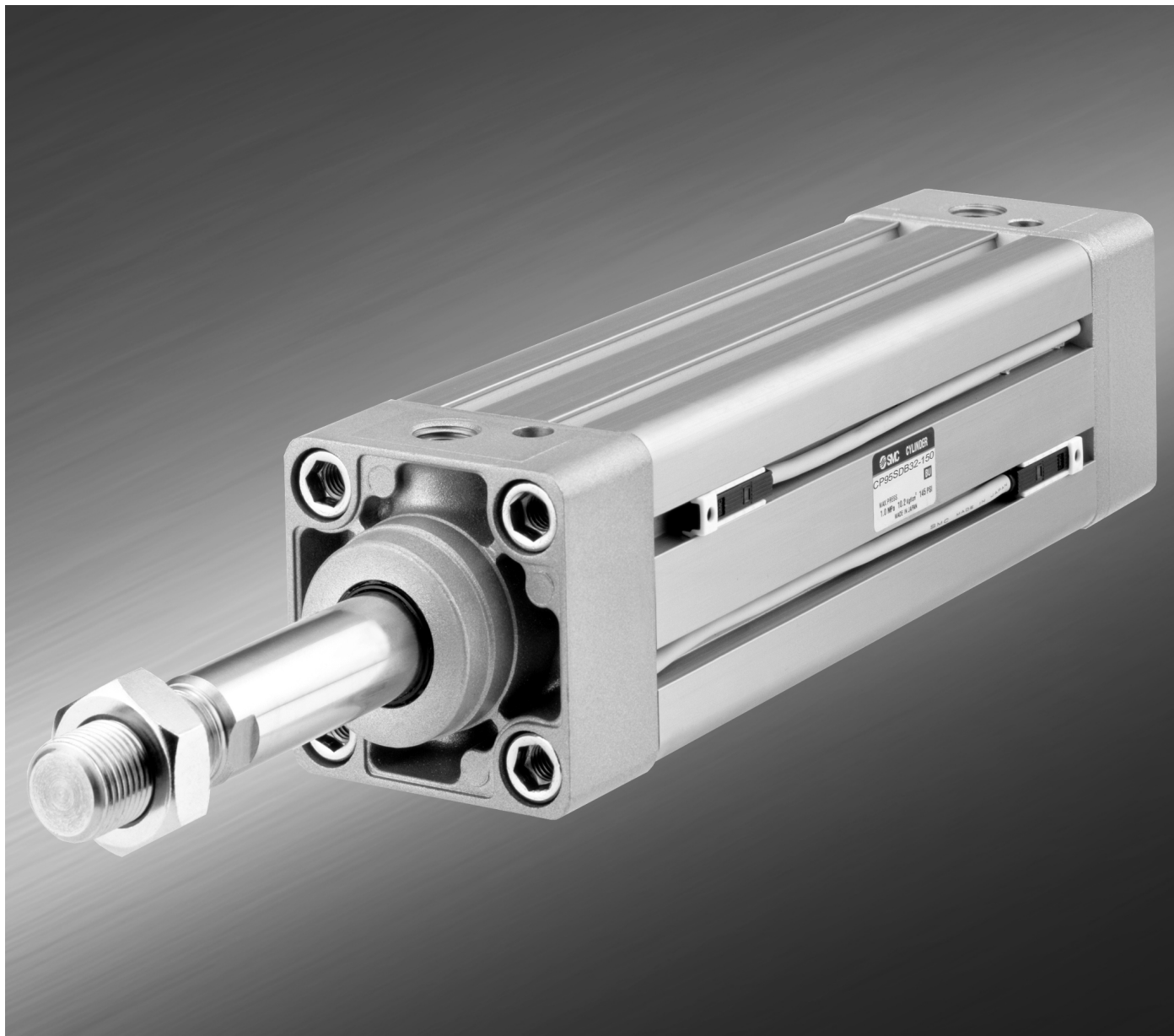

Series CP95
Ø32, Ø40, Ø50, Ø63, Ø80, Ø100



Profile design with enclosed tie-rods

Profile Design ISO/VDMA Air Cylinder

Series CP95

Improved end of stroke cushion capacity

Piston rod lurching has been eliminated at the end of stroke positions by means of a floating seal mechanism.

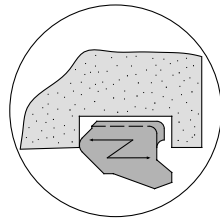

Increased kinetic energy absorption

The absorption of kinetic energy has been increased by nearly 30%, through increased cushion volume and the use of a new cushion seal.

Compact and light design

Die casting of the covers has reduced the weight by 25%.

Improved mounting accuracy

High accuracy covers and tie rod nuts simplify the mounting process and also extend cylinder life.

Piston rod deflection reduced

Deflection of the piston rod has been reduced by increasing the precision of the bushing and piston rod, and reducing the tolerances.

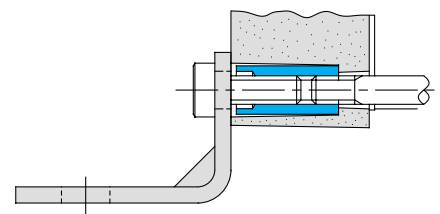

Ø32, Ø40, Ø50, Ø63, Ø80, Ø100

Space saving auto switch mounting

Space is saved by setting switches completely into grooves provided on 4 surfaces.

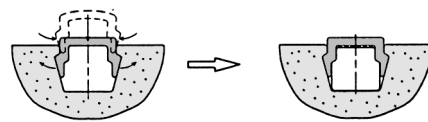

Port aperture

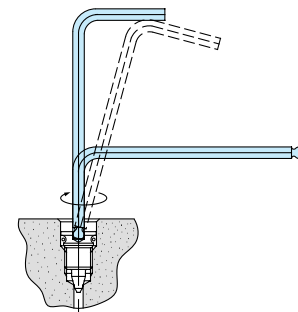

Easy end of stroke cushion valve adjustment

Since adjustment of the cushion valve is performed with a hexagon wrench key, even fine control can be easily accomplished. Furthermore, the cushion valve has been recessed so that it does not protrude from the cover.

Appearance improved by enclosing the tie-rods

Tie-rods are enclosed in an extruded aluminium profile barrel, which is integrated with both end covers to achieve a smooth and attractive appearance.

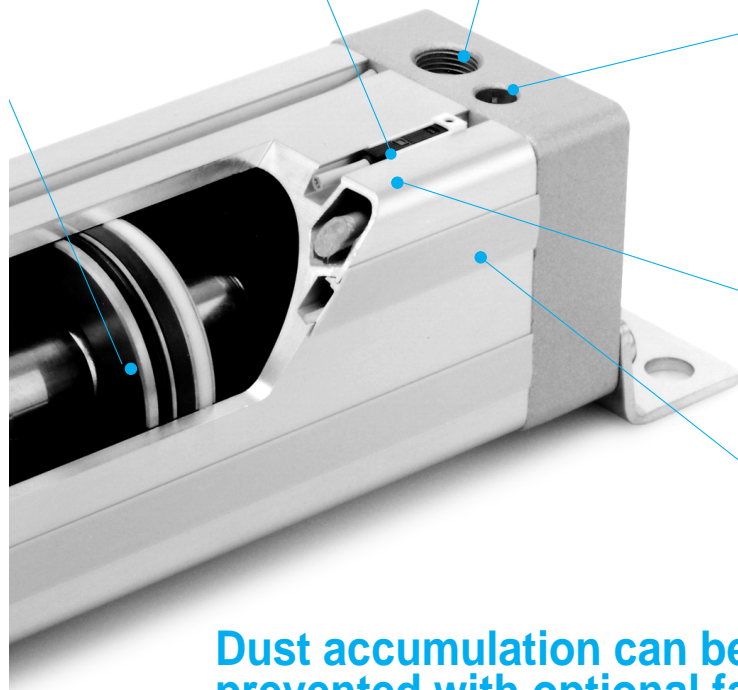

Dust accumulation can be prevented with optional fastener strips

Auto switch mounting grooves can be covered with resin fastener strips, which adhere tightly to the tube to prevent the entry and accumulation of dirt.

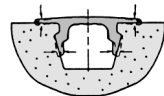

Key Page Index

	Page
Available Specifications	4
How to Order	4-5
Technical Specifications	6, 13
Dimensions (Cylinders).....	9-12, 15-17
(Mounting Accessories)	18
Auto Switches	19-22
Guide Units	23-25
Safety Instructions.....	30-34
Main Index.....	35
	1.8-3

Series CP95 ISO/VDMA Air Cylinders

Specifications

Type	Model	Bore						Stroke end cushioning as standard	Rod specifications				Upon receipt or order XB6	
		32	40	50	63	80	100		Standard type hard chromed	W	E	R		
Double acting	Standard	CP95SB	•	•	•	•	•	•	•	•	•	•	•	•
		CP95SDB	•	•	•	•	•	•	•	•	•	•	•	–
	Double rod	CP95SB•W	•	•	•	•	•	•	•	•	–	•	•	•
		CP95SDB•W	•	•	•	•	•	•	•	•	–	•	•	–
	Non-rotating rod	CP95KB	•	•	•	•	•	•	•	–	•	•	•	–
		CP95KDB	•	•	•	•	•	•	•	–	•	•	•	–

W = double/through rod
E = extended rod
R = stainless rod
XB6= heat resistant (to 150° C)

• available
– not available

How to order: Cylinders

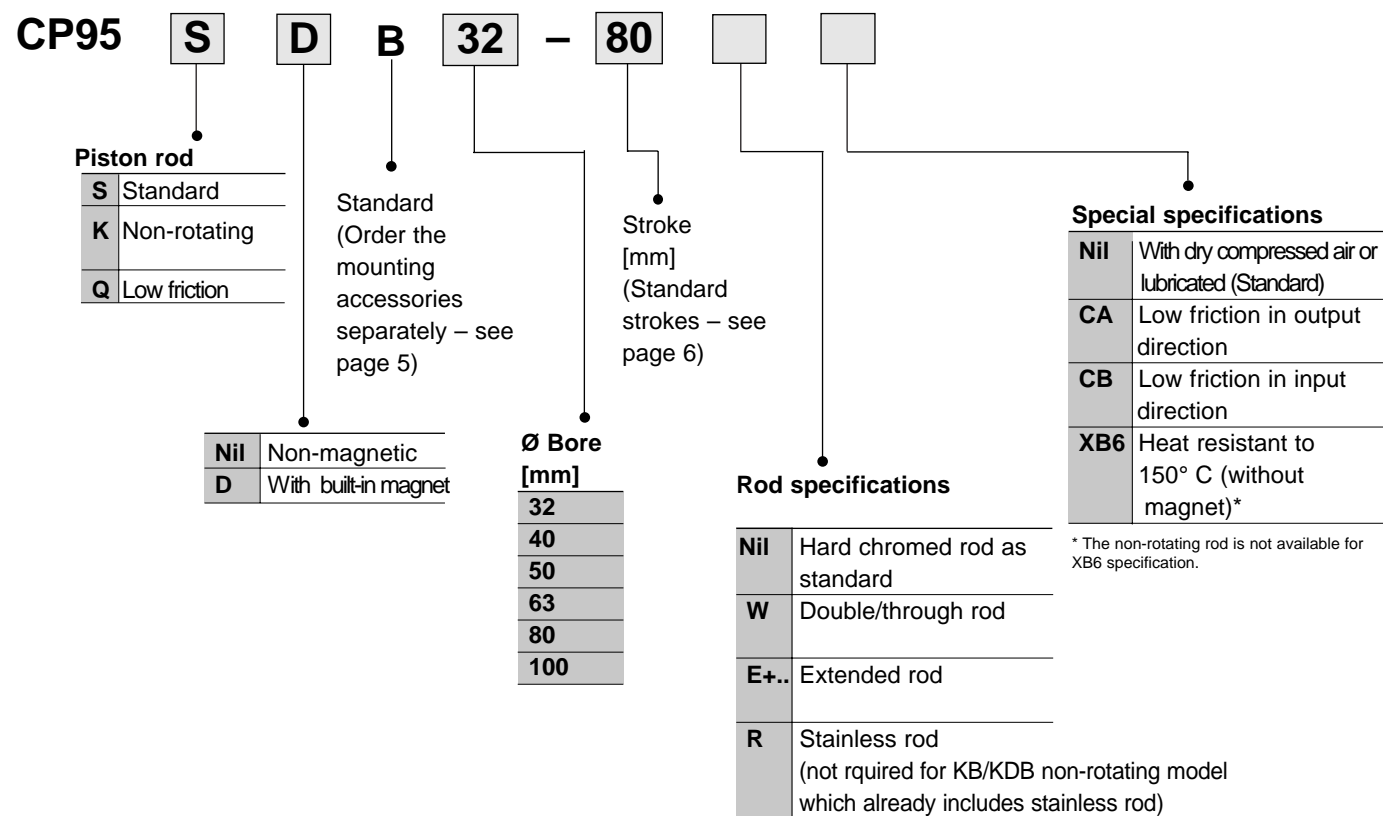

How to order: Accessories

	Page
Mounting accessories	Cylinder5
	Rod5
Switches and switch holders	19-22
Snap-on switch groove covers	22
Seal kits	standard models.....8
	1.8-4 non-rotating models.....

Series CP95

How to order mounting accessories

Mounting accessories, cylinders

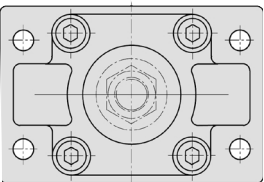
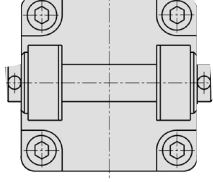
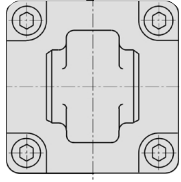
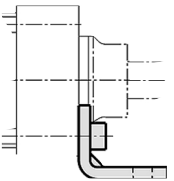
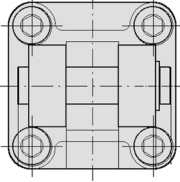
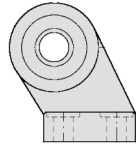
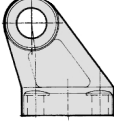
Ø bore	F Front/rear flange	D Female rear clevis (corresponds to E accessories)	C Male rear clevis	
	 Supplied with 4 screws	 Supplied with bolt, safety device and 4 screws	 Supplied with 4 screws	
32 40 50 63 80 100	F5032 F5040 F5050 F5063 F5080 F5100 See page 10 for dimensions	D5032 D5040 D5050 D5063 D5080 D5100 See pages 10/11 for dimensions	<u>Plain</u> C5032 C5040 C5050 C5063 C5080 C5100 See pages 10/11 for dimensions <small>Note: See page 11 for male rear clevis with swivel CR50</small>	
Ø bore	L Foot	DS Female rear clevis (for ES accessory)	ES Angled rear clevis with ball joint	E Angled rear clevis
	 Supplied with two pieces			
32 40 50 63 80 100	L5032 L5040 L5050 L5063 L5080 L5100 See page 10 for dimensions	DS5032 DS5040 DS5050 DS5063 DS5080 DS5100 See page 12 for dim.	ES5032 ES5040 ES5050 ES5063 ES5080 ES5100 See page 12 for dim.	E5032 E5040 E5050 E5063 E5080 E5100 See page 11 for dimensions

Mounting accessories, rod

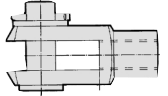
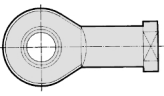
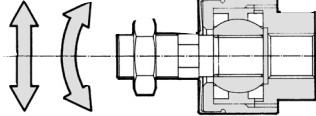
Ø bore	GKM Rod clevis DIN 71752	KJ Piston rod ball joint DIN 648	JA Floating joint
	 Supplied with bolts and safety devices		
32 40 50 63 80 100	GKM 10-20 GKM12-24 GKM16-32 GKM16-32 GKM20-40 GKM20-40 See page 18 for dimensions	KJ10 D KJ12 D KJ16 D KJ16 D KJ20D KJ20D See page 18 for dimensions	JA30-10-125 JA40-12-125 JA50-16-150 JA50-16-150 JAH50-20-150 JAH50-20-150 See page 18 for dimensions

ISO/VDMA Air Cylinder

Series CP95 VDMA

Double acting with end of stroke cushioning Ø32 - Ø100

- Conforms to VDMA 24 562 (parts 1 and 2), ISO 6431 and CETOP standards
- Combines lightweight profile barrel design with enclosed tie rods for extra strength
- Unique seal system ensures efficient performance and long life
- Fully adjustable cushioning at end of stroke
- Magnetic proximity sensing
- Superior cushioning performance and kinetic energy absorption

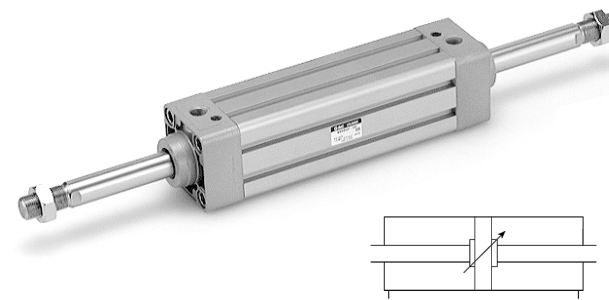

Technical specifications

Bore [mm]	32	40	50	63	80	100
Type	Non-lube type					
Action	Double acting single rod					
Fluid	Compressed air filtered to <10 µm, lubricated or non lubricated (dry air)					
Proof pressure	1.5MPa {15.3kgf/cm ² }					
Maximum operating pressure	1.0MPa {10.2kgf/cm ² }					
Minimum operating pressure	0.05MPa {0.5kgf/cm ² }					
Piston force	Up to 7500N					
Piston rod	Hard chromed steel (25µm finish)					
Lubrication	Not required (non-lube)					
Rod diameter [mm]	12	16	20	20	25	30
Piston rod thread	M10x1.25	M12x1.25	M16x1.5	M16x1.5	M20x1.5	M20x1.5
Ports	G1/8	G1/4	G1/4	G3/8	G3/8	G1/2
Cushioning stroke [mm]	19	19	24	24	30	30
Mounting position	Any					
Standard strokes (DIN ISO 4393) [mm]	25, 50, 80, 100, 125, 160, 200, 250, 320, 400, 500, 600, 700, 800					
Stroke tolerance [mm]	Other stroke lengths in accordance with ISO497 R 10					
Working pressure [MPa]	<250mm: + 1.0/-0mm, <1000mm: + 1.4/-0mm, <1500mm: + 1.8/-0mm					
Fluid and ambient temperature [°C]	-10°C to +60°C, -10°C to +70°C without magnet					
Piston speed [mm/s]	50 - 1000					

Standard strokes

Ø Bore	Standard stroke	Max. stroke
32	25, 50, 80, 100, 125, 160, 200, 250, 320, 400, 450, 500	700
40	25, 50, 80, 100, 125, 160, 200, 250, 320, 400, 450, 500	800
50	25, 50, 80, 100, 125, 160, 200, 250, 320, 400, 450, 500, 600	1200
63	25, 50, 80, 100, 125, 160, 200, 250, 320, 400, 450, 500, 600	1200
80	25, 50, 80, 100, 125, 160, 200, 250, 320, 400, 450, 500, 600, 700, 800	1400
100	25, 50, 80, 100, 125, 160, 200, 250, 320, 400, 450, 500, 600, 700, 800	1500

Note: Intermediate strokes are also available

Series CP95

Theoretical output table [N]

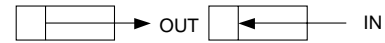

Ø Bore [mm]	Ø Rod diam. [mm]	Operating direction	Piston area [mm²]	Working pressure [MPa]									
				0.2	0.3	0.4	0.5	0.6	0.7	0.8	0.9	10	
32	12	OUT	804	161	241	322	402	482	563	643	724	804	
		IN	691	138	207	276	346	415	484	553	622	691	
40	16	OUT	1257	251	377	503	629	754	880	1006	1131	1257	
		IN	1056	211	317	422	528	634	739	845	950	1056	
50	20	OUT	1963	393	589	785	982	1178	1374	1570	1767	1963	
		IN	1649	330	495	660	825	989	1154	1319	1484	1649	
63	20	OUT	3117	623	935	1247	1559	1870	2182	2494	2805	3117	
		IN	2803	561	841	1121	1402	1682	1862	2242	2523	2803	
80	25	OUT	5027	1005	1508	2011	2514	3016	3519	4022	4524	5027	
		IN	4536	907	1361	1814	2268	2722	3175	3629	4082	4536	
100	30	OUT	7854	1571	2356	3142	3927	4712	5498	6283	7069	7854	
		IN	7147	1429	2144	2859	3574	4288	5003	5718	6432	7147	

Note: Theoretical output OUT [N] = Pressure [MPa] x Piston area [mm²]

Weight table

Ø Bore	Mounting type	32	40	50	63	80	100
Basic weight	Basic type B	0.59	0.87	1.44	2.00	3.37	4.45
	Foot L	0.16	0.20	0.38	0.46	0.89	1.09
	Front/rear flange F	0.20	0.23	0.47	0.58	1.30	1.81
	Male rear clevis C	0.16	0.23	0.37	0.60	1.07	1.73
	Female rear clevis D	0.20	0.32	0.45	0.71	1.28	2.11
	Angled rear clevis E	0.16	0.22	0.42	0.52	0.94	1.40
	Female rear clevis DS	0.17	0.27	0.45	0.64	1.37	2.05
	Spherical bearing ES	0.18	0.27	0.46	0.55	0.97	1.33
Additional weight per 50 mm stroke		0.11	0.17	0.28	0.40	0.67	0.89
Accessories	Piston rod ball joint KJ	0.15	0.23	0.26	0.26	0.60	0.83
	Rod clevis GKM	0.22	0.37	0.43	0.43	0.87	1.27
	Floating joint JA	0.015	0.20	0.26	0.26	0.9	0.9

Weight calculation method

Example: CP95S32-100

(basic Ø32, 100st)

- Basic weight0.59kg (Standard Ø32)
- Additional weight . . .0.11kg/50mm stroke
- Cylinder stroke . . .100st

Cylinder weight = 0.59+(0.11 x 100/50)=0.81kg

Kinetic energy absorbable by air cushion mechanism

Ø Bore [mm]	Cushioning stroke [mm]	Absorbable kinetic energy [J]
32	19	2.2
40	19	3.4
50	24	5.9
63	24	11
80	30	20
100	30	29

$$E = \frac{1}{2} m \cdot v^2$$

E: Kinetic energy [J = Nm]
m: Load weight [kg]
v: Piston speed [m/s]

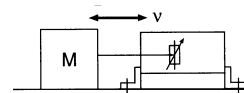

Note: v is final velocity which is 1.4 • average velocity.

If the kinetic energy obtained is no greater than the absorbable kinetic energy shown in the table above, the life of the cushion seal should be 10 million cycles or more.

At the stroke end, when stopping a large amount of kinetic energy generated by a large load and high speed operation, compression of air is used to absorb the impact without transmitting vibration to the surroundings. The purpose of an air cushion is not to reduce the speed of a piston as it nears the stroke end. The kinetic energy of a load can be found using the following formula:

Moveable mass at various piston speeds

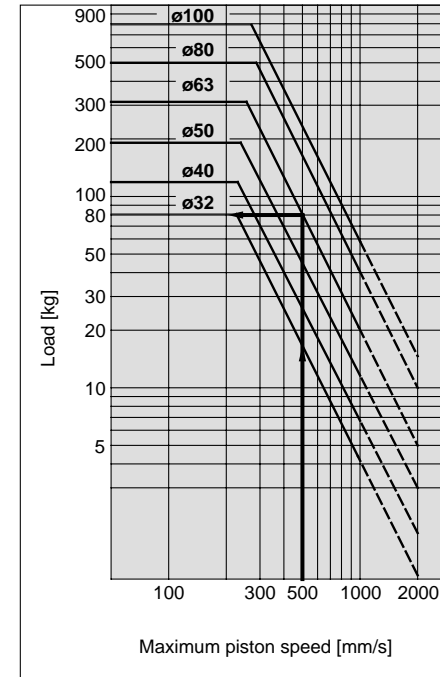

Example: Find the rod end load limit when a ø63 air cylinder is operated at a maximum drive speed of 500mm/s. Extend upward from 500mm/s on the horizontal axis of the graph to the intersection point with the line for a tube bore of 63mm, and then extend leftward from this point to find the load of 80kg.

Series CP95

Construction

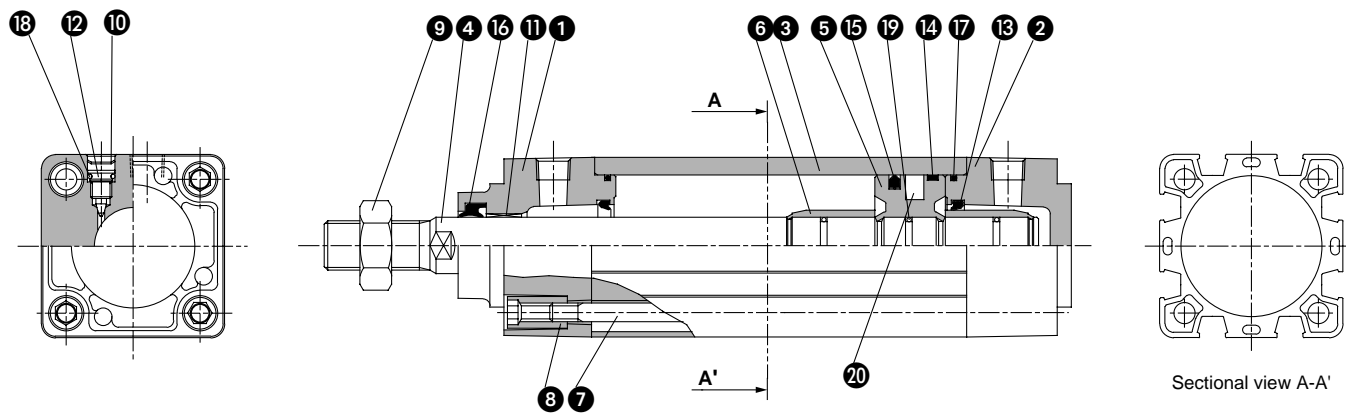

Parts list

No.	Description	Material
1	Head cover	Die-cast aluminum
2	End cover	Die-cast aluminum
3	Cylinder tube	Die-cast aluminum
4	Piston rod	Hard chromed steel C45
5	Piston	Die-cast aluminum
6	Cushion ring	Brass
7	Tie rod	Steel, zinc chromate plated
8	Tie rod nut	Steel, zinc chromate plated
9	Rod end nut	Steel, zinc chromate plated
10	Snap ring	Steel nickel plated
11	Bushing	Lead-bronze casting
12	Cushion valve	Steel, zinc chromate plated
13	Cushion seal	Elastomer
14	Wear ring	Antifriction material
15	Piston seal	NBR
16	Rod seal	NBR
17	Cylinder tube gasket	NBR
18	Cushioning valve seal	NBR
19	Piston/rod gasket	NBR
20	Magnet ring	

Maximum allowable radial loads

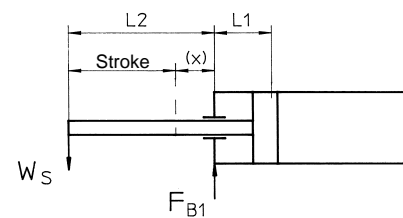

$$F_{B1} = W_S \left(1 + \frac{L2}{L1}\right) \leq F_{B \text{ allowable}}$$

Ø	L1	L2	$F_{B1 \text{ allowable}}$
32	62.5	34.5 + st	80 N
40	74.0	39.0 + st	125 N
50	76.0	44.5 + st	195 N
63	91.0	44.5 + st	310 N
80	93.0	53.0 + st	500 N
100	104.0	57.5 + st	785 N

e.g. 63mm bore, 100mm stroke, $W_S = 20N$

$W_S = (2kgs) 20N$

$$F_{B1} = 20 \left(1 + \frac{144.5}{91}\right) = 51.76N$$

$$F_{B1} = 51.76N \leq 310N \text{ (from table)}$$

Therefore, side load is allowable

Replacement parts: Seal kits

Ø32 includes order No. from 13 to 17,
Ø40 - Ø100 includes from 12 to 18

Ø	Order No.
32	CS95-32
40	CS95-40
50	CS95-50
63	CS95-63
80	CS95-80
100	CS95-100

Dimensions - standard specifications

[mm]

CP95S□BØ-stroke

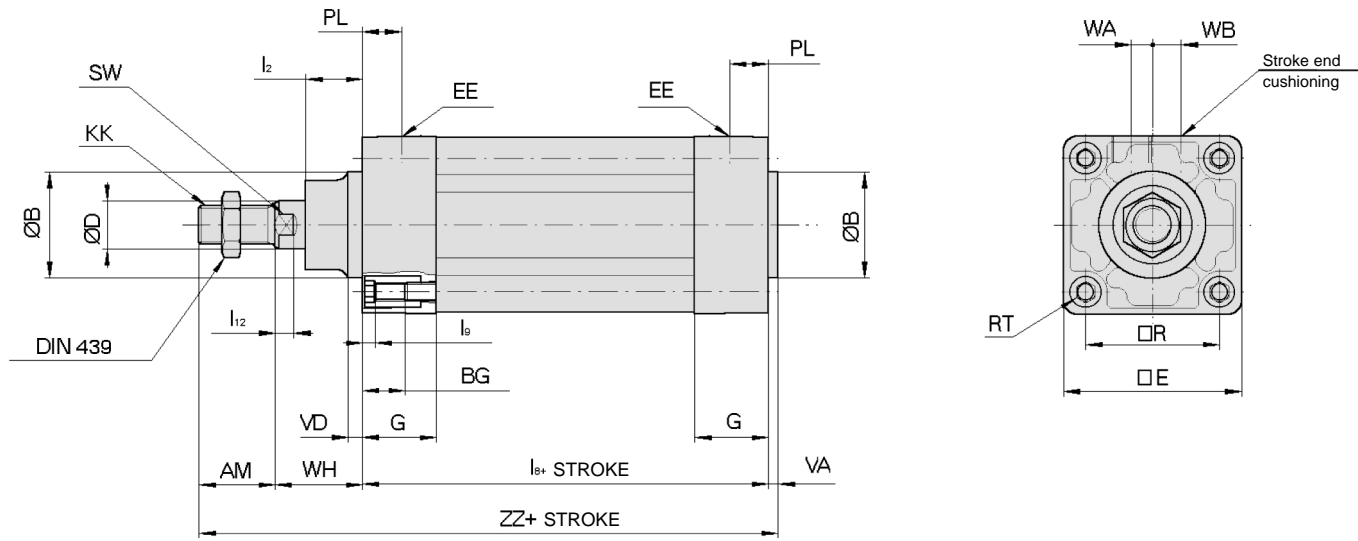

CP95S□BØ-stroke W

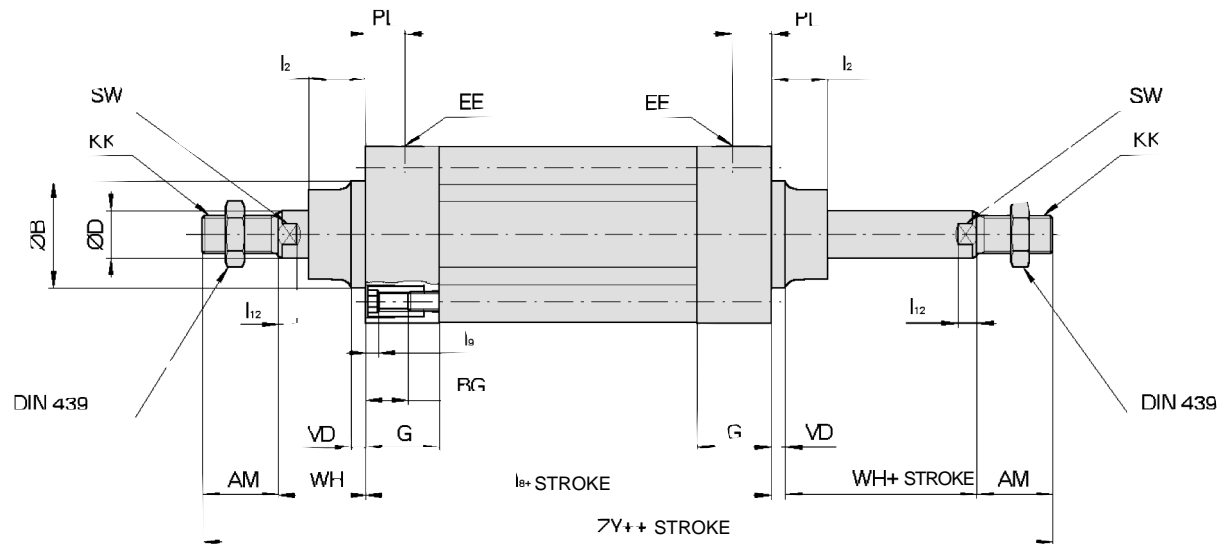

Ø Bore	AM	ØB	ØD	EE	PL	RT	I ₁₂	KK	SW	G	BG	I ₈	VD	VA	WA	WB	WH	ZZ	ZY	ØE	ØR	I ₂	I ₉
32	22	30	12	G1/8	13	M6	6	M10x1.25	10	27	16	94	4	4	4	6.5	26	146	190	46	32.5	15	4
40	24	35	16	G1/4	14	M6	6.5	M12x1.25	13	27	16	105	4	4	4	9	30	163	213	52	38	17	4
50	32	40	20	G1/4	15.5	M8	8	M16x1.5	16	31.5	16	106	6	4	5	10.5	37	179	244	65	46.5	24	5
63	32	45	20	G3/8	16.5	M8	8	M16x1.5	16	31.5	16	121	6	4	9	12	37	194	259	75	56.5	24	5
80	40	45	25	G3/8	19	M10	10	M20x1.5	21	38	16	128	8	4	11.5	14	46	218	300	95	72	30	5
100	40	55	30	G1/2	19	M10	10	M20x1.5	21	38	16	138	8	4	17	15	51	233	320	114	89	32	5

Series CP95

Dimensions – mounting accessories L, F, C and D

[mm]

Mounting type L

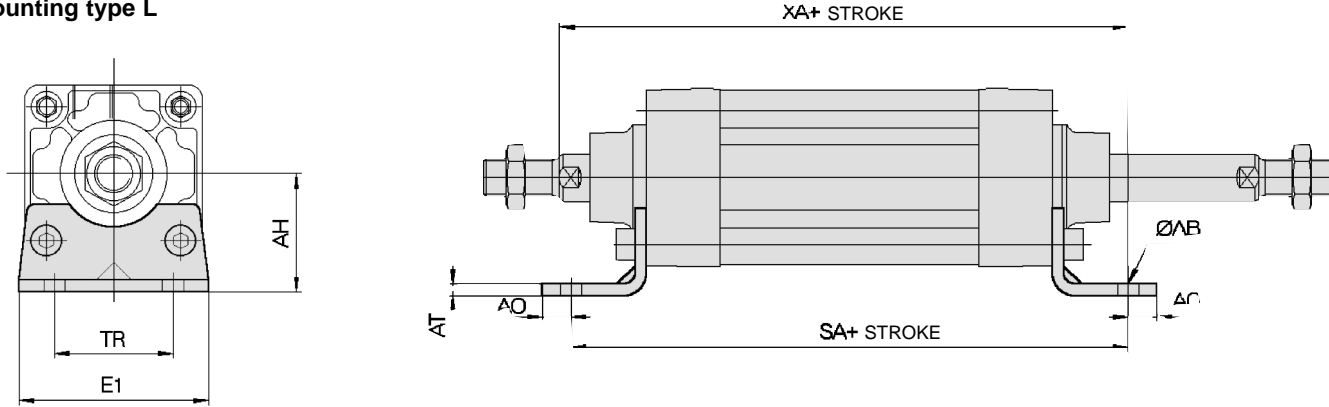

Mounting type F

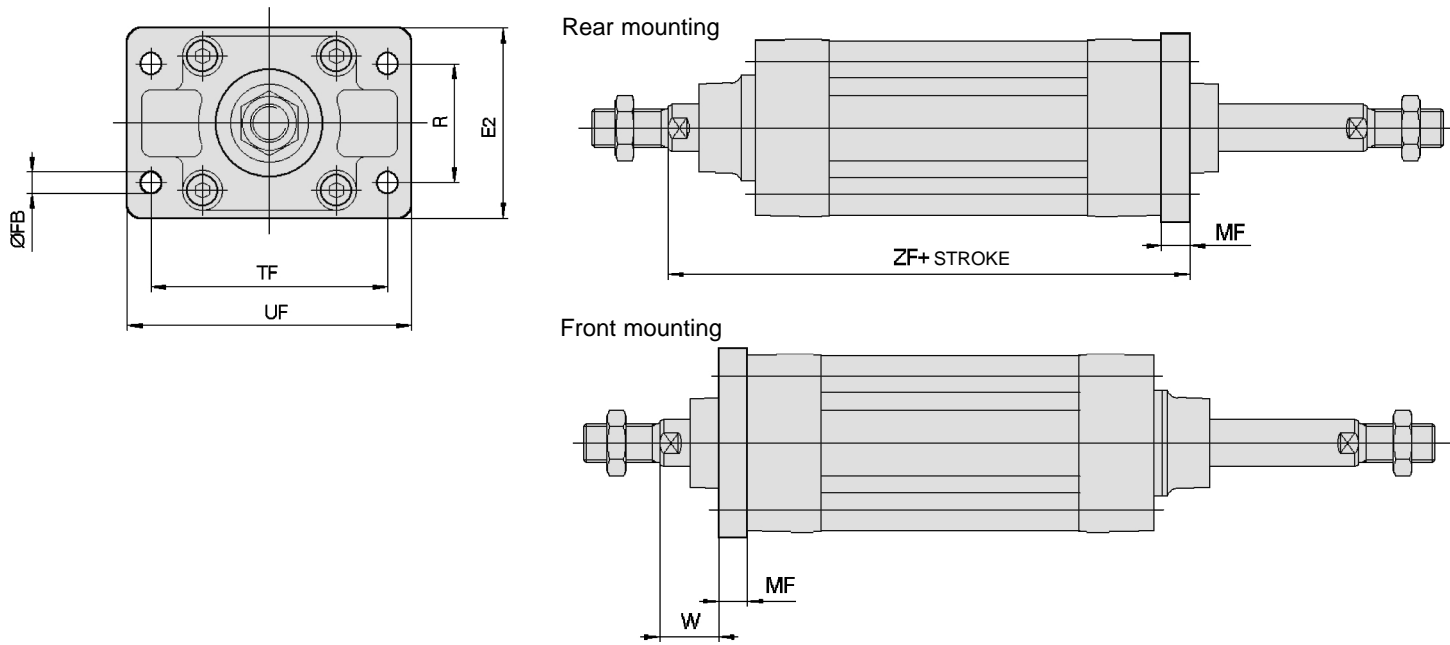

Mounting type C

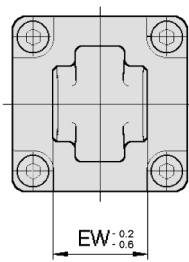

Mounting type D

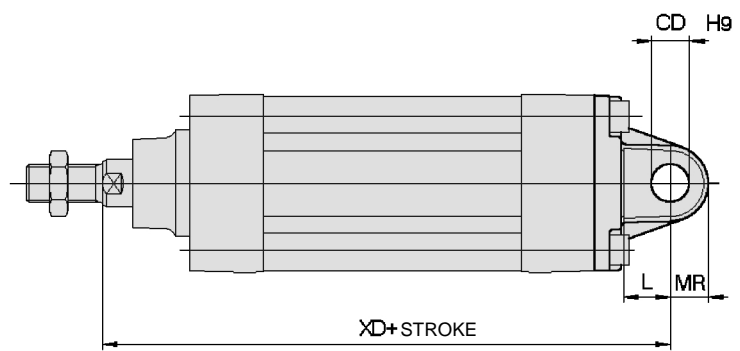
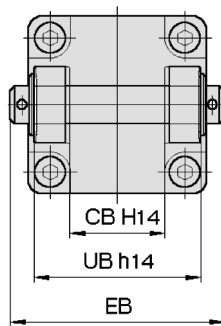

Ø Bore	E1	R	W	MF	ZF	ØFB	CD	EB	L	XD	UB	CB	EW	MR	TR	AO	AT	XA	SA	AH	ØAB	TF	UF	E2
32	48	32	16	10	130	7	10	65	12	142	45	26	26	9.5	32	10	4	144	142	32	7	64	79	50
40	55	36	20	10	145	9	12	75	15	160	52	28	28	12	36	11	4	163	161	36	9	72	90	55
50	68	45	25	12	155	9	12	80	15	170	60	32	32	12	45	12	5	175	170	45	9	90	110	70
63	80	50	25	12	170	9	16	90	20	190	70	40	40	16	50	12	5	190	185	50	9	100	120	80
80	100	63	30	16	190	12	16	110	20	210	90	50	50	16	63	14	6	215	210	63	12	126	153	100
100	120	75	35	16	205	14	20	140	25	230	110	60	60	20	75	16	6	230	220	71	14	150	178	120

Dimensions – mounting accessories C, D, E and CR

[mm]

Mounting type C

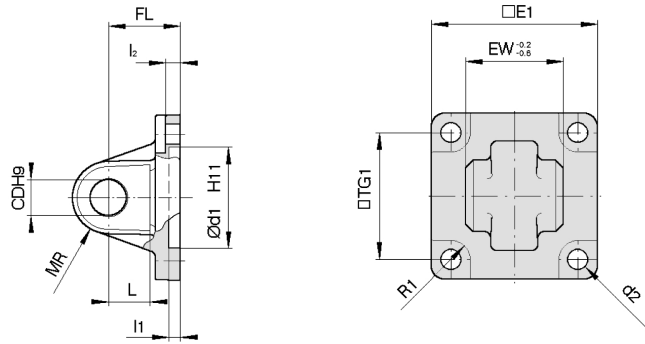

Mounting type D

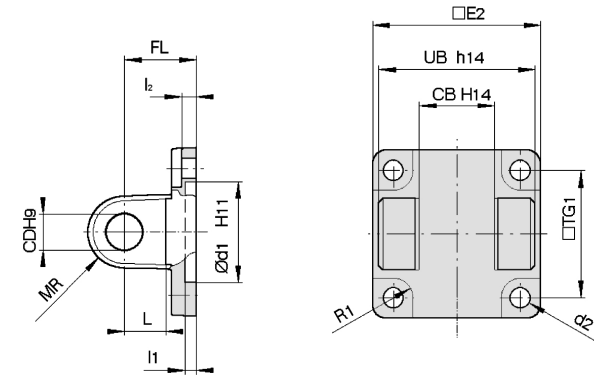

Ø Bore	E1	EW	TG1	FL	l ₁	L	l ₂	Ød1	CD	MR	d2	R1	E2	UB	CB
32	45	26	32.5	22	5	12	5.5	30	10	9.5	6.6	6.5	48	45	26
40	51	28	38	25	5	15	5.5	35	12	12	6.6	6.5	56	52	28
50	64	32	46.5	27	5	15	6.5	40	12	12	9	8.5	64	60	32
63	74	40	56.5	32	5	20	6.5	45	16	16	9	8.5	75	70	40
80	94	50	72	36	5	20	10	45	16	16	11	11	95	90	50
100	113	60	89	41	5	25	10	55	20	20	11	12	115	110	60

Mounting type E

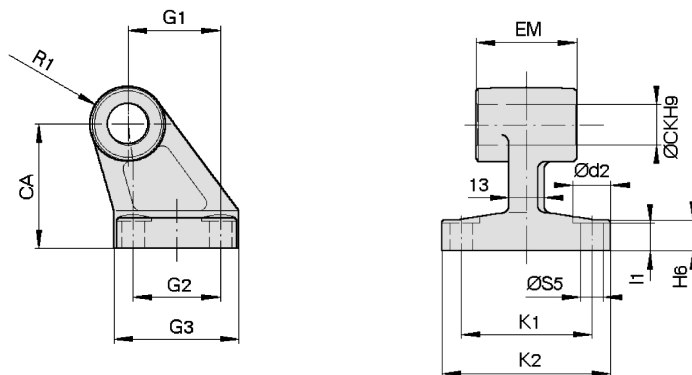

Ø Bore	Ød2	ØCK	ØS5	K1	K2	l3	G1	l ₁	G2	EM	G3	CA	H6	R1
32	11	10	6.6	38	51	10	21	7	18	26	31	32	8	10
40	11	12	6.6	41	54	10	24	9	22	28	35	36	10	11
50	15	12	9	50	65	12	33	11	30	32	45	45	12	12
63	15	16	9	52	67	14	37	11	35	40	50	50	12	15
80	18	16	11	66	86	18	47	12.5	40	50	60	63	14	15
100	18	20	11	76	96	20	55	13.5	50	60	70	71	15	19

Mounting type CR Rear clevis with ball joint

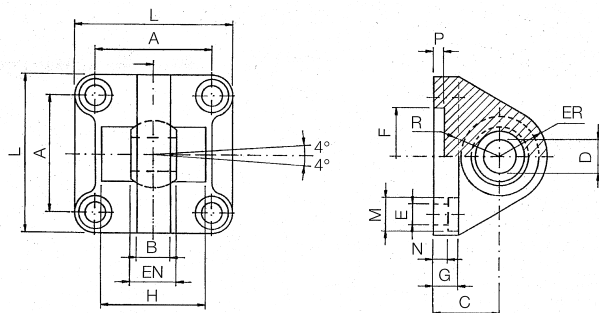

Ø	A	B	C	D	EN	ER	ØF	G	E	L	M	N	P	H	R
(mm)	±0.2	maxi	JS15H7	-0.1	maxi	H11	H13	H13	±0.5	±0.5	±0.5	±0.5	±0.5	±0.5	±0.5
32	32.5	10.5	22	10	14	15	30	10	6.6	45	10.5	5.5	5	-	-
40	38	12	25	12	16	18	35	10	6.6	55	11	5.5	5	-	-
50	46.5	15	27	16	21	20	40	10	9	65	15	6.5	5	51	19
63	56.5	15	32	16	21	23	45	12	9	75	15	6.5	5	-	-
80	72	18	36	20	25	27	45	14	11	95	18	10	5	-	-
100	89	18	41	20	25	30	55	16	11	115	18	10	5	-	-

Series CP95

Dimensions – mounting accessories DS and ES

[mm]

Mounting type DS

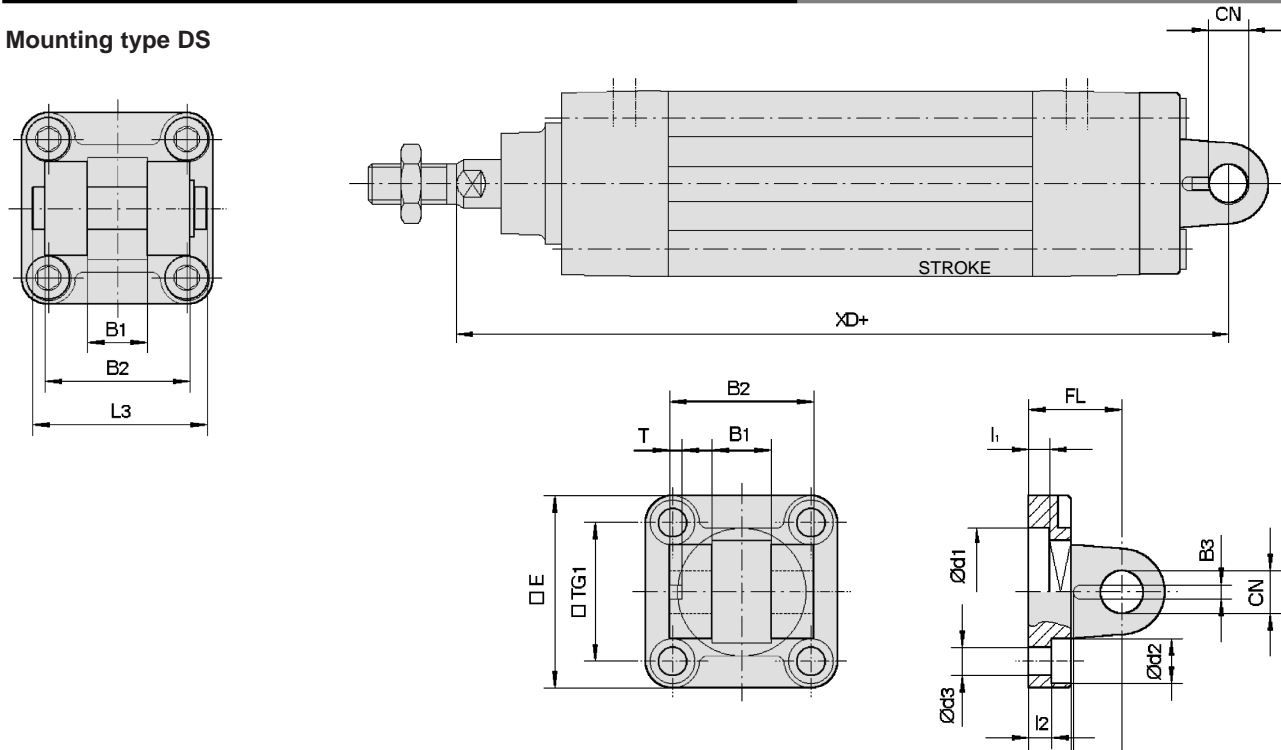

Ø Bore	□E	B1	B2	B3	□TG1	T	L1	L3	I ₁	I ₂	FL	H	Ød1	Ød2	Ød3	CN	XD
32	45	14	34	3.3	32.5	3	11.5	41	5	5.5	22	10	30	10.5	6.6	10	142
40	55	16	40	4.3	38	4	12	48	5	5.5	25	10	35	11	6.6	12	160
50	65	21	45	4.3	46.5	4	14	54	5	6.5	27	10	40	15	9	16	170
63	75	21	51	4.3	56.5	4	14	60	5	6.5	32	12	45	15	9	16	190
80	95	25	65	4.3	72	4	16	75	5	10	36	16	45	18	11	20	210
100	115	25	75	6.3	89	4	16	85	5	10	41	16	55	18	11	20	230

Mounting type ES

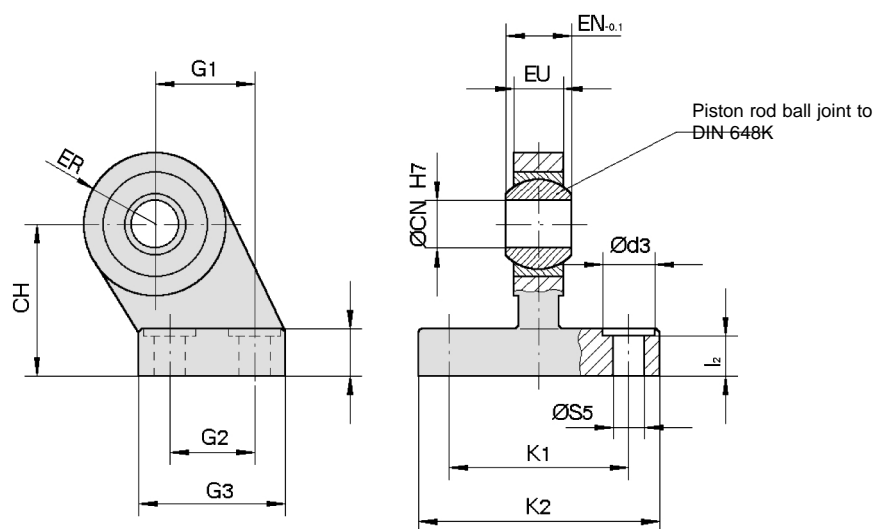

Ø Bore	Ød3	ØCN	ØS5	K1	K2	I ₂	G1	G2	G3	EN	EU	CH	H6	ER
32	11	10	6.6	38	51	8.5	21	18	31	14	10.5	32	10	15
40	11	12	6.6	41	54	8.5	24	22	35	16	12	36	10	18
50	15	16	9	50	65	10.5	33	30	45	21	15	45	12	20
63	15	16	9	52	67	10.5	37	35	50	21	15	50	12	23
80	18	20	11	66	86	11.5	47	40	60	25	18	63	14	27
100	18	20	11	76	96	12.5	55	50	70	25	18	71	15	30

ISO/VDMA Air Cylinders

Series CP95K

Double acting with end of stroke cushioning and non-rotating rod
 Ø32 - Ø100

- Conforms to VDMA 24 562 (parts 1 and 2), ISO 6431 and CETOP standards
- Combines lightweight profile barrel design with enclosed tie rods for extra strength
- Unique seal system ensures efficient performance and long life
- Fully adjustable cushioning at end of stroke
- Magnetic proximity sensing
- Superior cushioning performance and kinetic energy absorption

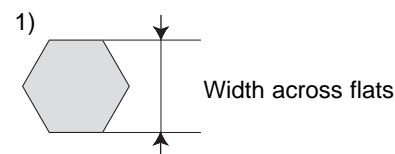
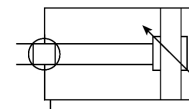

Technical specifications

Bore [mm]	32	40	50	63	80	100
Type	Non-lube type air cylinder					
Action	Double acting single rod					
Fluid	Compressed air filtered to < 10 µm, lubricated or non lubricated (dry air)					
Proof pressure	1.5MPa {15.3kgf/cm ² }					
Maximum operating pressure	1.0MPa {10.2kgf/cm ² }					
Minimum operating pressure	0.05MPa {0.5kgf/cm ² }					
Piston force	Up to 7500N					
Rod width across flats [mm] ¹⁾	12.2	14.2	19	19	23	27
Piston rod thread	M10 x 1.25	M12 x 1.25	M16 x 1.5	M16 x 1.5	M20 x 1.5	M20 x 1.5
Ports	G1/8	G1/4	G1/4	G3/8	G3/8	G1/2
Cushioning stroke [mm]	19	19	24	24	30	30
Mounting position	Any					
Standard strokes [mm]	25, 50, 80, 100, 125, 160, 200, 250, 320, 400, 500, 600, 700, 800					
(DIN ISO 4393) [mm]	Other stroke lengths in accordance with ISO 497 R 10					
Stroke tolerance [mm]	<250mm: +1.0/-0mm, <1000mm: +1.4/-0mm					
Working pressure [MPa]	0.05 - 1.0					
Fluid and ambient temperature [°C]	-10°C to +60°C built-in magnet / -10°C to +70°C without magnet					
Piston speed [mm/s]	50 - 1000					
Rod non-rotating accuracy	± 0.5°	± 0.5°	± 0.5°	± 0.5°	± 0.3°	± 0.3°
Allowable maximum stroke [mm] ²⁾	700	800	1200		1400	1500
Allowable Torque [Nm]	0.25	0.45	0.64	0.64	0.79	0.93
Rod material	Stainless steel					

²⁾ For longer stroke lengths please contact SMC.

Series CP95K

Construction

Parts list

No.	Description	Material
1	Head cover	Die-cast aluminum
2	End cover	Die-cast aluminum
3	Cylinder tube	Die-cast aluminum
4	Piston rod	Stainless Steel
5	Piston	Die-cast aluminum
6	Cushion ring	Brass
7	Tie rod	Steel, zinc chromate plated
8	Tie rod nut	Steel, zinc chromate plated
9	Rod end nut	Steel, zinc chromate plated
10	Snap ring	Steel nickel plated
11	Bushing	Lead-bronze casting
12	Cushion valve	Steel, zinc chromate plated
13	Cushion seal	Elastomer
14	Wear ring	Antifriction material
15	Piston seal	NBR
16	Rod seal	NBR
17	Cylinder tube gasket	NBR
18	Cushioning valve seal	NBR
19	Piston/rod gasket	NBR
20	Magnet ring	

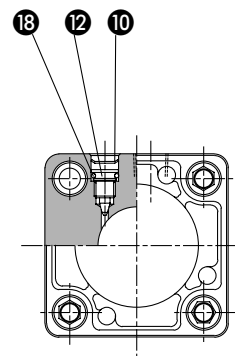
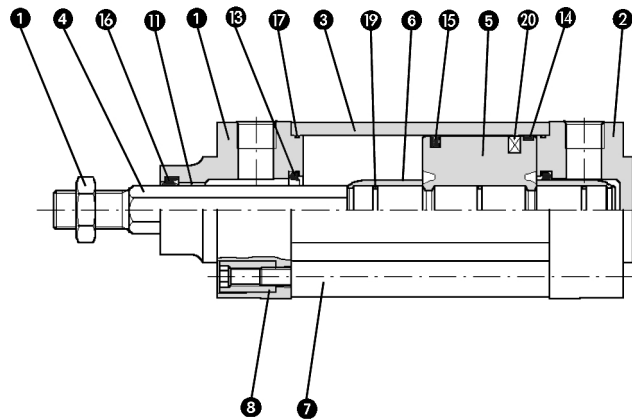

Replacement parts: Seal kits

Ø32 includes the order No. from 13 to 17,
Ø40-Ø100 includes from 12 to 18.

Ø Bore	Order No.
32	CK95-32
40	CK95-40
50	CK95-50
63	CK95-63
80	CK95-80
100	CK95-100

Theoretical output table

The value at the OUT side is the same as the double acting single rod type, but the value at the IN side is different. Refer to the table below.

Bore size (mm)	Piston area (mm ²)	Bore size (mm)	Piston area (mm ²)
32	675	63	2804
40	1082	80	4568
50	1651	100	7223

Theoretical output (N) = Pressure (MPa) x Piston area (mm²).
1N: approx. 0.102kgf 1MPa: approx. 10.2kgf/cm²

Dimensions – non-rotating rod specification

[mm]

CP95K□BØ-Stroke

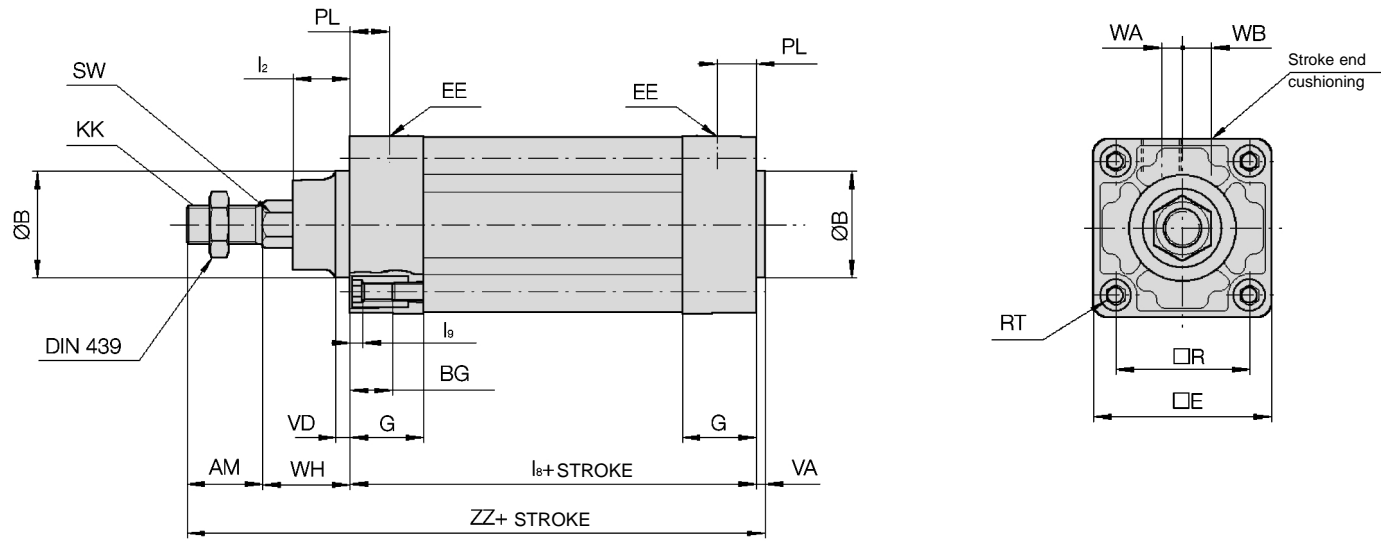

CP95K□BØ-Stroke W

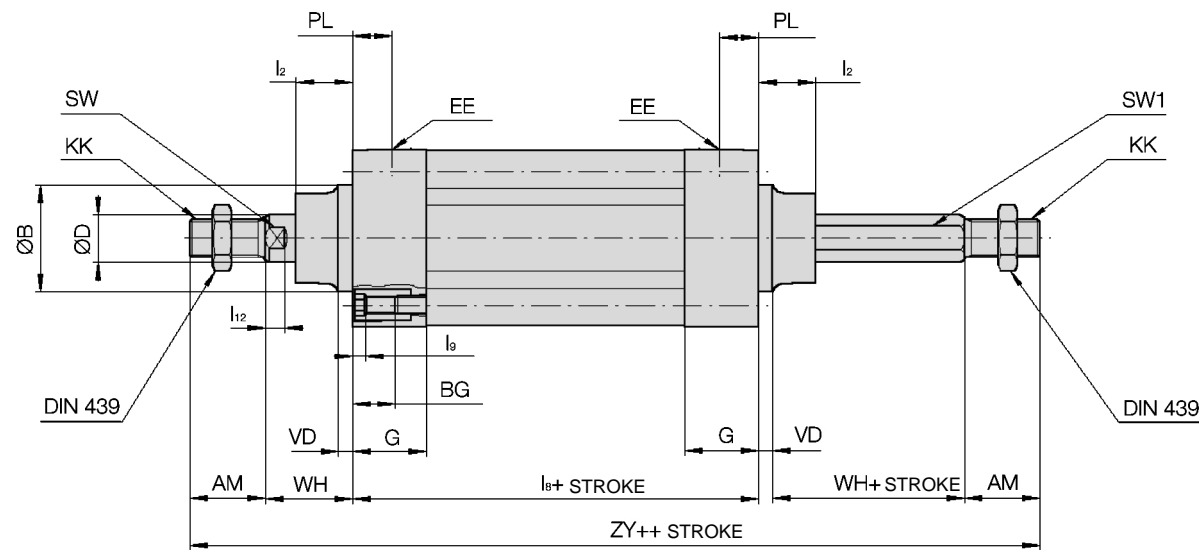

Ø Bore	AM	ØB	ØD	EE	PL	RT	l ₁₂	KK	SW	SW1	G	BG	l _g	VD	VA	WA	WB	WH	ZZ	ZY	□E	□R	l ₂	l _g
32	22	30	12	G1/8	13	M6	6	M10x1.25	10	12.2	27	16	94	4	4	4	6.5	26	146	190	46	32.5	15	4
40	24	35	16	G1/4	14	M6	6.5	M12x1.25	13	14.2	27	16	105	4	4	4	9	30	163	213	52	38	17	4
50	32	40	20	G1/4	15.5	M8	8	M16x1.5	16	19	31.5	16	106	6	4	5	10.5	37	179	244	65	46.5	24	5
63	32	45	20	G3/8	16.5	M8	8	M16x1.5	16	19	31.5	16	121	6	4	9	12	37	194	259	75	56.5	24	5
80	40	45	25	G3/8	19	M10	10	M20x1.5	21	23	38	16	128	8	4	11.5	14	46	218	300	95	72	30	5
100	40	55	30	G1/2	19	M10	10	M20x1.5	21	27	38	16	138	8	4	17	15	51	233	320	114	89	32	5

Series CP95K

Cylinder mounting accessories dimensions L, F, C and D

[mm]

Mounting type L

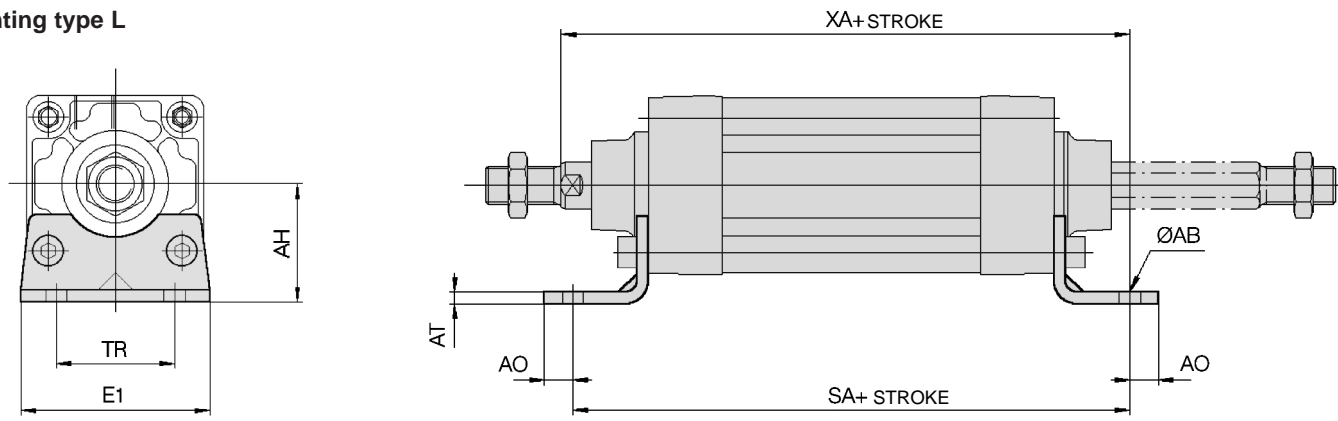

Mounting type F

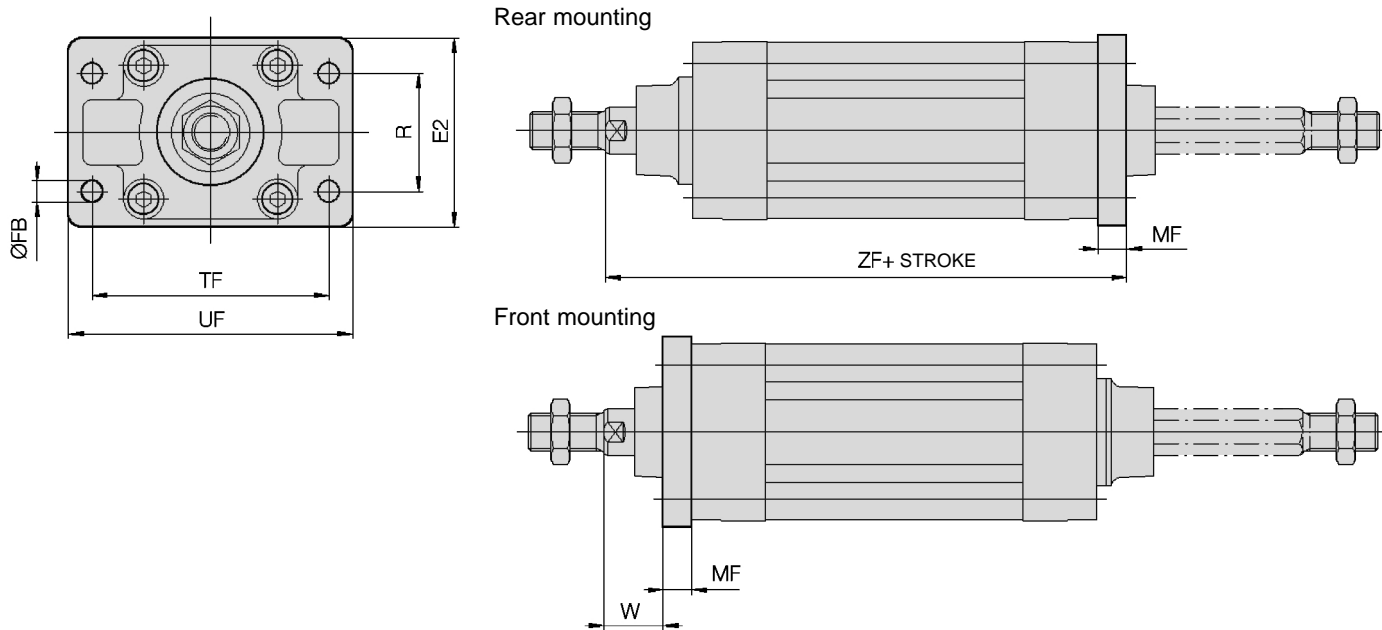

Mounting type C

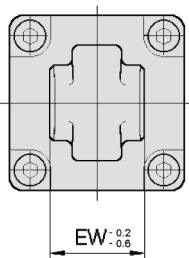

Mounting type D

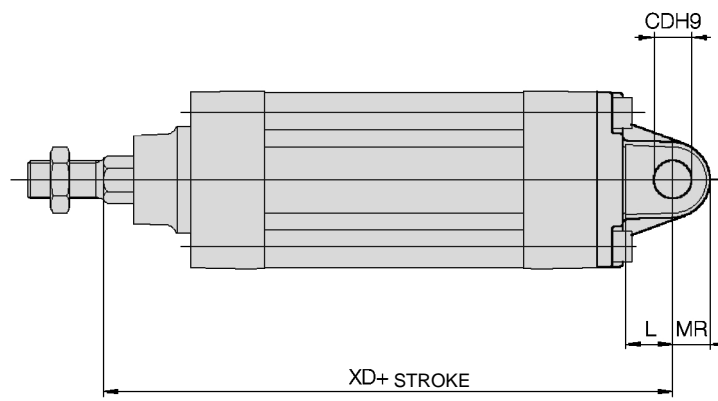
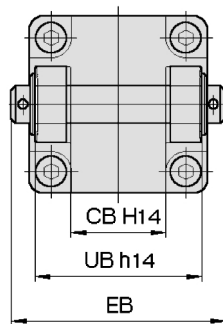

Ø Bore	E1	R	W	MF	ZF	ØFB	CD	EB	L	XD	UB	CB	EW	MR	TR	AO	AT	XA	SA	AH	ØAB	TF	UF	E2
32	48	32	16	10	130	7	10	65	12	142	45	26	26	9.5	32	10	4	144	142	32	7	64	79	50
40	55	36	20	10	145	9	12	75	15	160	52	28	28	12	36	11	4	163	161	36	9	72	90	55
50	68	45	25	12	155	9	12	80	15	170	60	32	32	12	45	12	5	175	170	45	9	90	110	70
63	80	50	25	12	170	9	16	90	20	190	70	40	40	16	50	12	5	190	185	50	9	100	120	80
80	100	63	30	16	190	12	16	110	20	210	90	50	50	16	63	14	6	215	210	63	12	126	153	100
100	120	75	35	16	205	14	20	140	25	230	110	60	60	20	75	16	6	230	220	71	14	150	178	120

Cylinder mounting accessory DS and ES

[mm]

Mounting type DS

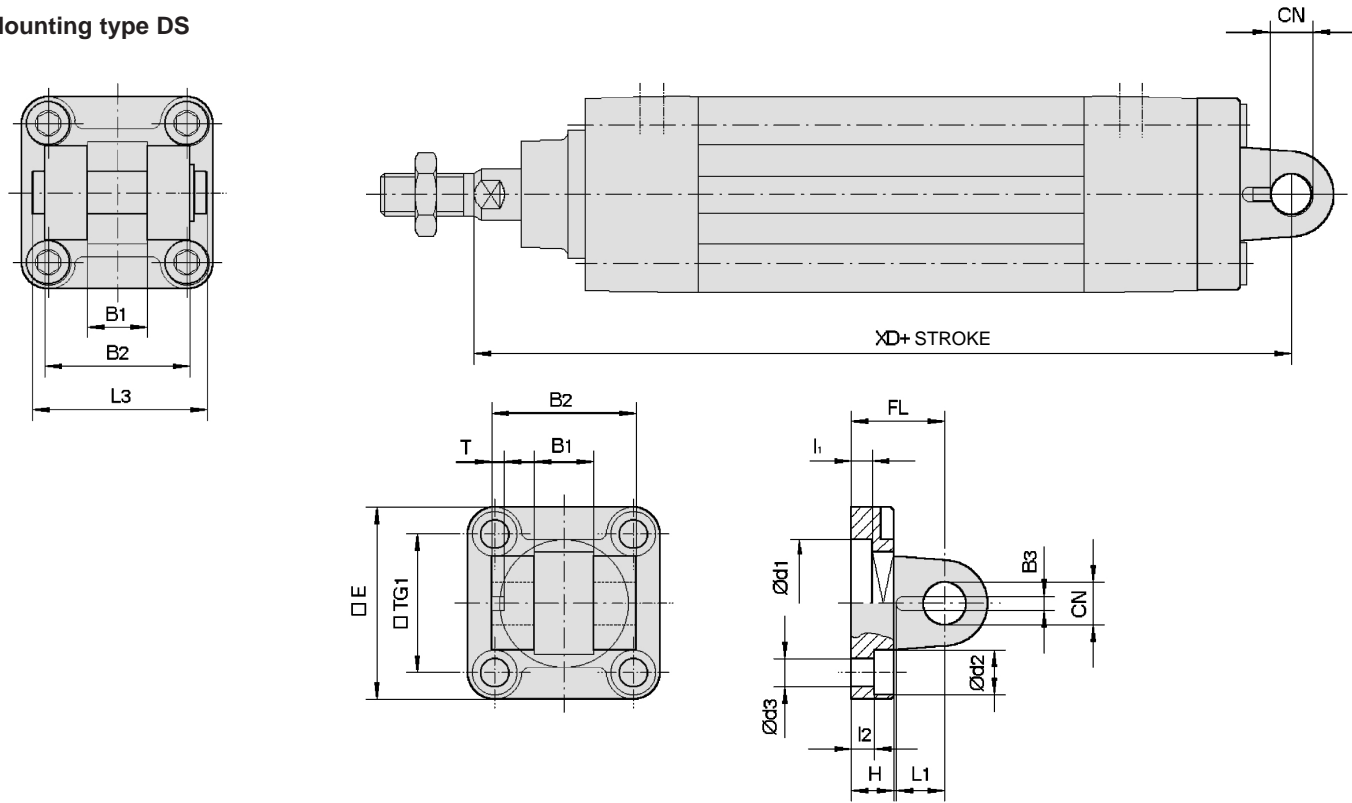

Ø Bore	□E	B1	B2	B3	□TG1	T	L1	L3	l ₁	l ₂	FL	H	Ød1	Ød2	Ød3	CN	XD
32	45	14	34	3.3	32.5	3	11.5	41	5	5.5	22	10	30	10.5	6.6	10	142
40	55	16	40	4.3	38	4	12	48	5	5.5	25	10	35	11	6.6	12	160
50	65	21	45	4.3	46.5	4	14	54	5	6.5	27	10	40	15	9	16	170
63	75	21	51	4.3	56.5	4	14	60	5	6.5	32	12	45	15	9	16	190
80	95	25	65	4.3	72	4	16	75	5	10	36	16	45	18	11	20	210
100	115	25	75	6.3	89	4	16	85	5	10	41	16	55	18	11	20	230

Mounting type ES

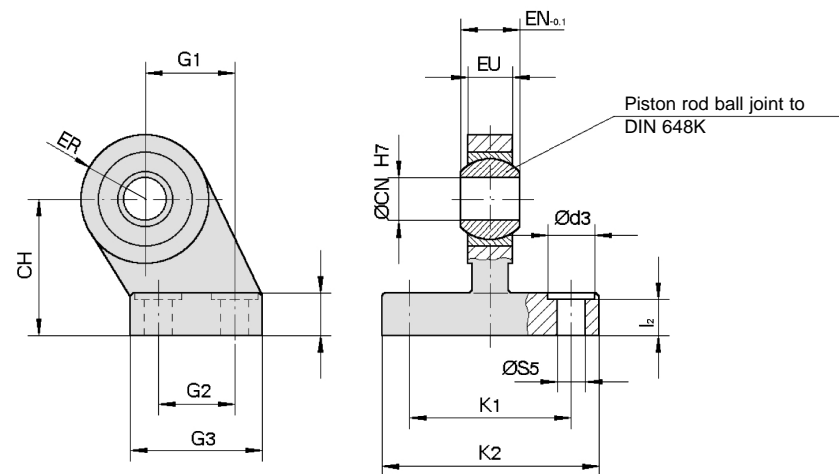

Ø Bore	Ød3	ØCN	ØS5	K1	K2	l ₂	G1	G2	G3 □	EN	EU	CH	H6	ER
32	11	10	6.6	38	51	8.5	21	18	31	14	10.5	32	10	15
40	11	12	6.6	41	54	8.5	24	22	35	16	12	36	10	18
50	15	16	9	50	65	10.5	33	30	45	21	15	45	12	20
63	15	16	9	52	67	10.5	37	35	50	21	15	50	12	23
80	18	20	11	66	86	11.5	47	40	60	25	18	63	14	27
100	18	20	11	76	96	12.5	55	50	70	25	18	71	15	30

Series CP95

Piston Rod mounting accessory dimensions

[mm]

Floating joint JA
Carbon tool steel

Ø Bore	M	Order No.	A	B	C	ØD	E	F	G	H	P	U	Load [kN]	Weight [g]	Angle
32	M10x1.25	JA30-10-125	49.5	19.5	-	24	5	8	8	17	9	0.5	2.5	70	±5°
40	M12x1.25	JA40-12-125	60	20	-	31	6	11	11	22	13	0.75	4.4	160	
50/63	M16x1.5	JA50-16-150	71.5	22	-	41	7.5	14	13.5	27	15	1.0	11	300	
80/100	M20x1.5	JAH50-20-150	101	28	31	59.5	11.5	24	16	32	18	2.0	18	1080	

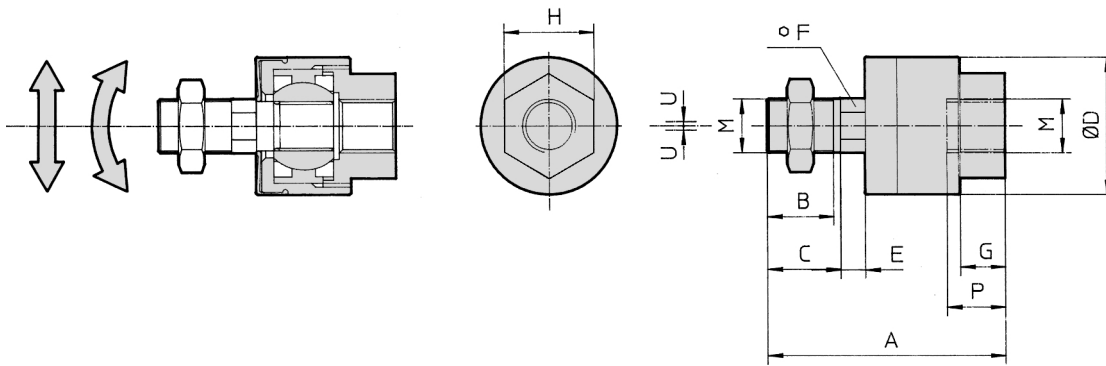

Rod clevis GKM (DIN 71752), supplied with bolt and safety device
Chromed steel

Ø Bore	e	Order No.	b	d	Øf	l1	c	a
32	M10x1.25	GKM10-20	10	40	10	52	20	20
40	M12x1.25	GKM12-24	12	48	12	62	24	24
50/63	M16x1.5	GKM16-32	16	64	16	83	32	32
80/100	M20x1.5	GKM20-40	20	80	20	105	40	40

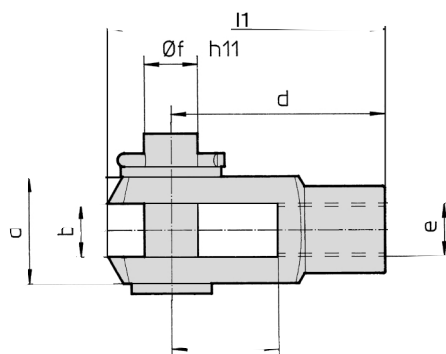

Rod end nut
(standard equipment)

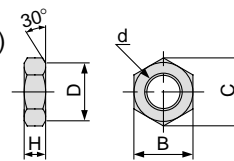

Order No.	Bore size (mm)	d	H	B	C	D
NT-03	32	M10 x 1.25	6	17	19.6	16.5
NT-04	40	M14 x 1.5	8	22	25.4	21
NT-05	50, 63	M18 x 1.5	11	27	31.2	26
NT-08	80	M22 x 1.5	13	32	37.0	31
NT-10	100	M26 x 1.5	16	41	47.3	39

Piston rod ball joint KJ (DIN 648)
Zinc chromate plated steel

Ø Bore	d3	Order No.	d1	h	d6	b3	b1	l	d7	α	l3	sw
32	M10x1.25	KJ10D	10	43	28	10.5	14	20	19	13°	14	17
40	M12x1.25	KJ12D	12	50	32	12	16	22	22	13°	16	19
50/63	M16x1.5	KJ16D	16	64	42	15	21	28	27	15°	26	32
80/100	M20x1.5	KJ20D	20	77	50	18	25	33	34	15°	26	32

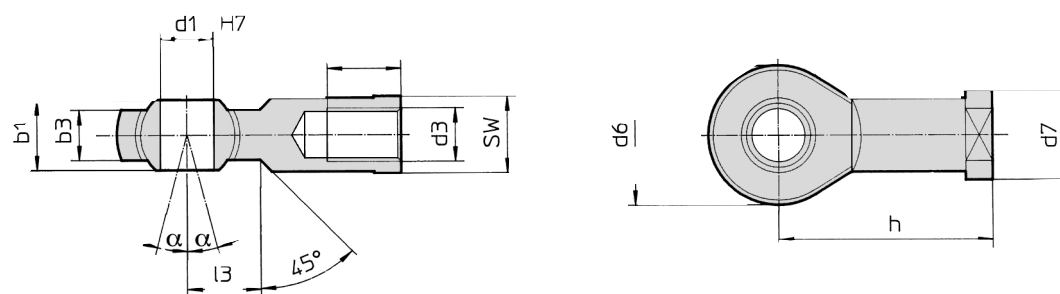

1.8-18

Series CP95 Auto Switch Specifications

Reed switch D-Z73L / D-Z80L



Technical specifications

D-Z73L, (with indicator light), lead wire length: 3 m

Model	D-Z73L	
Applicable load	Relay, PLC	
Power supply voltage	24VDC	100VAC
Load current	5 - 40 mA	5 - 20 mA
Protection internal circuits	-	
Internal voltage drop	< 2.4 V	
Indicator light	Red LED lights up when ON	

D-Z80L (without indicator light), lead wire length: 3 m

Model	D-Z80L		
Applicable load	Relay, SPS, IC circuit		
Power supply voltage	< 24VAC, DC	48VAC, DC	100VAC, DC
Load current	50 mA	40 mA	18 mA
Protection internal circuits	-		
Insulation resistance	Max. 1Ω		
Indicator light	-		

- Leakage current — 0
- Operating time — 1.2ms
- Lead wires — oil resistant vinyl cable, Ø 3.4 mm, 0.2 mm², 2 wires (Brown, Blue)
- Impact resistance — 30G
- Insulation resistance — >50MΩ with a 500VDC megohmmeter
- Withstand voltage — 1500VAC (for 1 minute)
- Ambient and fluid temperature — -10 to 60°C
- Protective structure — IEC IP67, waterproof (JISC0920), oil resistant

Internal circuits

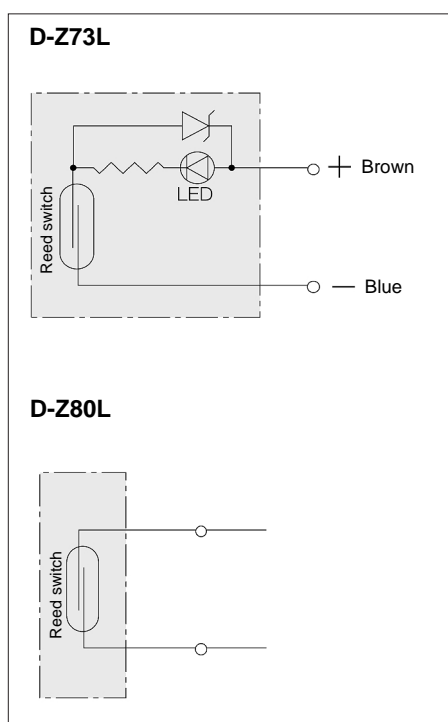

Dimensions

[mm]

D-Z73L / D-Z80L

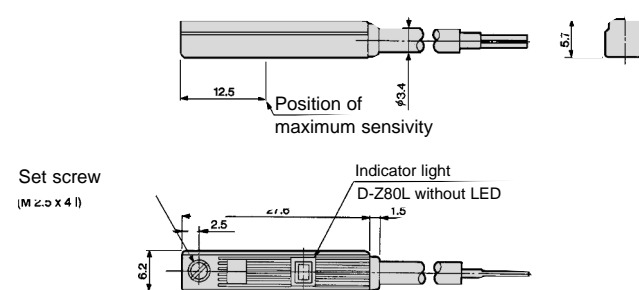

Series CP95 Auto Switch Specifications

Solid state D-Y7, 3 wires



Technical specifications

D-Y7PL (with indicator light), lead wire length 3 m

Model	D-Y7PL	D-Y7PVL
Wiring system	3 wires, axial	3 wires, vertical
Output system	PNP	
Applicable load	IC circuit, relay, PLC	
Power supply voltage	4.5VDC - 28 VDC	
Current consumption	OFF: < 1 mA, ON: < 15 mA	
Load current	< 80 mA	
Internal voltage drop	< 0.8V	
Leakage current	0.1 mA	
Indicator light	Red LED lights up when ON	

- **Operating time** — 1.2ms
- **Lead wires**— oil resistant vinyl cabtyre cable, \varnothing 3.4 mm, 0.2 mm², 3wires (Brown, Black, Blue)
- **Impact resistance** — 30G
- **Insulation resistance** — >50M Ω with a 500VDC megohmmeter
- **Withstand voltage** — 1500VAC (for 1 minute)
- **Ambient temperature** — -10 to 60°C
- **Protective structure** — IEC IP67, waterproof (JISC0920), oil resistant

Internal circuits

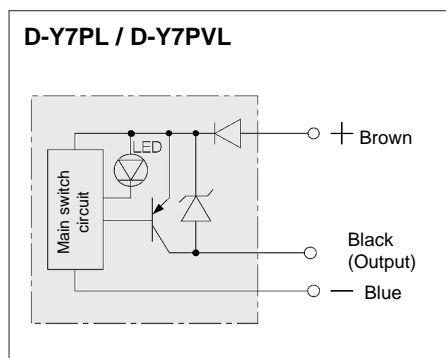

Dimensions

[mm]

D-Y7PL

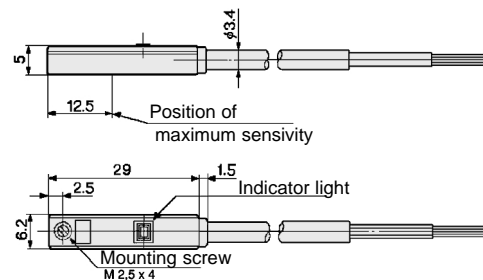

D-Y7PVL

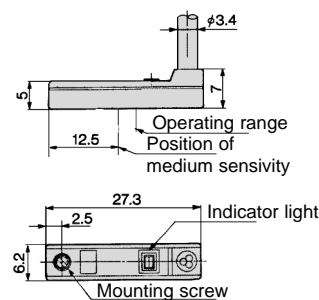

Series CP95 Auto Switch Specifications

Solid state D-Y59, D-Y69, 2 wires



Technical specifications

D-Y59BL / D-Y69BL (with indicator light), lead wire length: 3 m

Model	D-Y59BL	D-Y69BL
Wiring system	2 wires, axial	2 wires, vertical
Output system	—	—
Applicable load	relay DC, PLC	
Current consumption	—	
Power supply voltage	10 - 28VDC	
Load voltage	40 mA	
Internal voltage drop	< 4V	
Leakage current	< 0.8 mA a 24V	
Indicator light	Red LED lights up when ON	

- **Operating time** — 1ms
- **Lead wires** — Oil resistant vinyl cabtyre cable, \varnothing 3.4 mm, 0.2 mm², 2 wires (Brown,Blue)
- **Impact resistance** — 100 G
- **Insulation resistance** — >50M Ω with a 500VDC megohmmeter
- **Withstand voltage** — 1000VAC (for 1 minute)
- **Ambient temperature** — -10 to 60°C
- **Protective structure** — IEC IP67, waterproof (JISCO920), oil resistant

Internal circuits

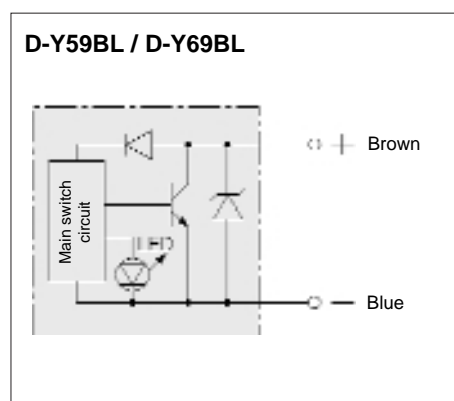

Dimensions

[mm]

D-Y59BL

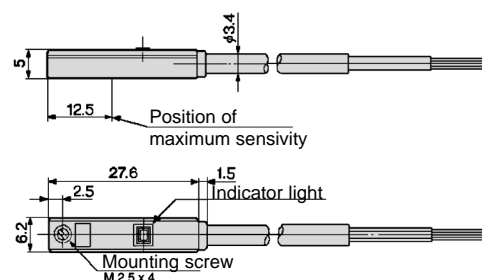

D-Y69BL

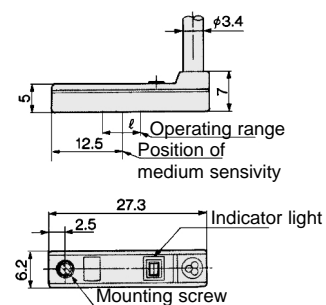

Series CP95

Auto switch mounting

[mm]



Minimum strokes for auto switches

Auto switch type	Model	Amount* of switches	Ø32	Ø40	Ø50	Ø63	Ø80	Ø100
Reed	D-Z73L	2 pcs.	25				15	
	D-Z80L	1 pcs.						
Solid state	D-Y59BL	2 pcs.	25				15	
	D-Y69BL	1 pcs.						
	D-Y7PL							

*Auto switches are mounted on the same side but in different grooves of the cylinder.

Recommended mounting position for stroke ends

[mm]

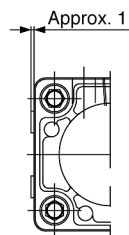
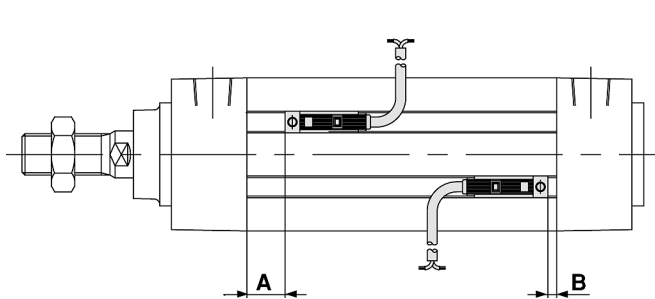

Bore (mm)	D-Z73L, D-Z80L, D-Y7PL D-Y59BL, D-Y69BL	
	A	B
32	14	1
40	25	1
50	16	2
63	31	2
80	21.5	5.5
100	31.5	5.5

Mounting of Auto Switches

1N-m: approx. 10.2kgf-cm

When attaching an auto switch, first take a switch holder between your fingers and press it into a switch mounting groove. When doing this, confirm that it is set in the correct mounting orientation, or reattach if necessary. Next, insert an auto switch into the groove and slide it until it is positioned under the switch holder. After establishing the mounting position, use a watchmakers flat head screw driver to tighten the switch mounting screw which is included.

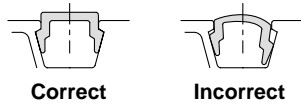

Switch holder: BMP1-032

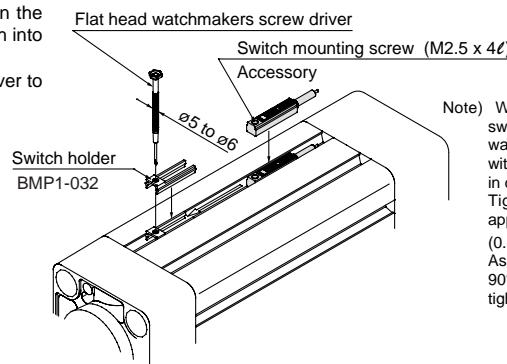

Note) When tightening the auto switch mounting screw, use a watchmakers screw driver with a handle about 5 to 6mm in diameter. Tighten to a torque of approximately 0.05 to 0.1Nm (0.51 to 1.02kgf-cm). As a rule, it is turned about 90° past the point at which tightening can be felt.

How to order: Auto Switches, holders and Groove Covers

Auto switch holder band

Ø	Order No.	
	Auto switch	Switch holder
32	D-Z73L	BMP1-032
40	D-Z80L	
50	D-Y7PL	
63	D-Y59BL	
80	D-Y69BL	
100		

Groove cover of square tube

Ø	Order No.	Cylinder length without stroke
32	CP95-AL <input type="checkbox"/>	41.5 mm
40		52.5 mm
50		44.5 mm
63		59.5 mm
80		53.5 mm
100		63.5 mm

Write the required length of the groove cover in the box.

Groove covers are available in progressive rates of 1 metre. Please, indicate round figures when ordering.

Order example: Groove cover for CP95SB63-160
 59.5 mm + 160 mm = 239.5 x 8 grooves = 1916 mm
 [Cylinder length without stroke] [Stroke] [8 grooves in the square tube]

Length to order: 1916 mm corresponds to a groove cover of 2 m for each cylinder
 Order No.: **CP95-AL** length in metres

Series CP95 Guide Units

- Ball bush and Slide Bearing options.
- High resistance to side load.
- High non-rotating accuracy.
- Direct Mounting facility.
- Stroke adjusting unit option. Ø32~Ø63

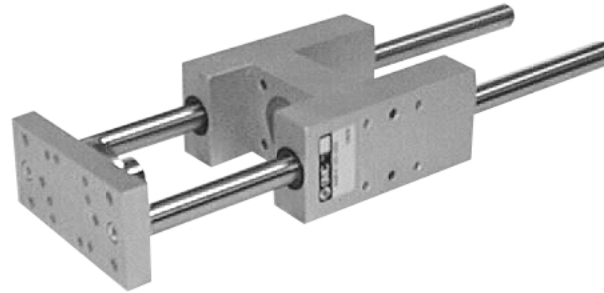

How to order: Guide Units

Slide bearing type

GUM (F) -

Bore Size (mm)	Stroke (mm)
32	Ø32
40	Ø40
50	Ø50
63	Ø63
80	Ø80
100	Ø100
	25
	50
	80
	100
	125
	160
	200
	250
	320
	400
	500

Bush bearing type

GUL (F) -

Bore Size (mm)	Stroke (mm)
32	Ø32
40	Ø40
50	Ø50
63	Ø63
80	Ø80
100	Ø100
	25
	50
	80
	100
	125
	160
	200
	250
	320
	400
	500

How to order: Stroke Adjusting Unit* and Shock Absorber*

Cylinder Bore Size (mm)	Part Number Stroke adjusting unit	Shock absorber
32	SFY(F)133	RBC1412
40	SFY(F)134	RBC2015
50	SFY(F)135	RBC2015
63	SFY(F)136	RBC2015

* Order separately

Series CP95

Dimensions GUM/GUL Guide Unit

[mm]

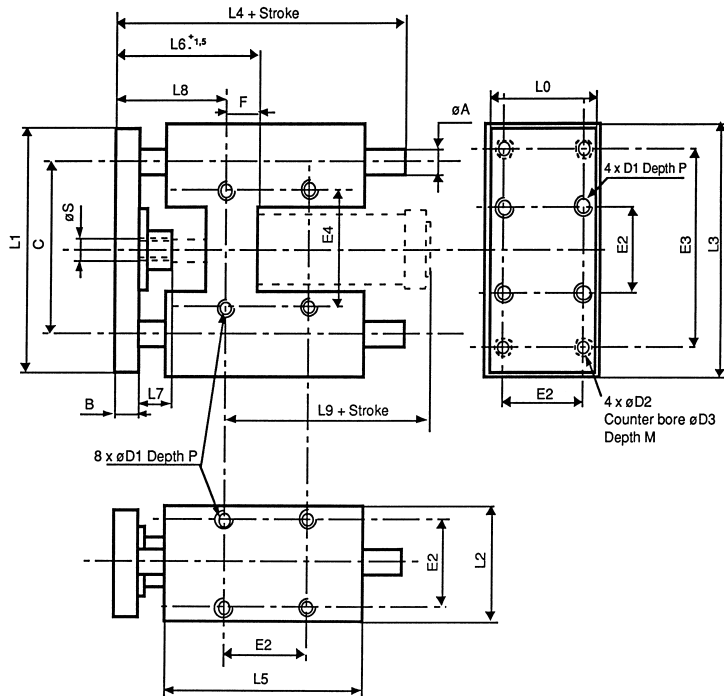

Diameter	A	B	C	D1	D2	D3	E2	E3	E4	F	L0	L1	L2	L3L	L4	L5	L6	L7	L8	L9	M	P	S
32	12	12	74	m6	6.6	11	33	78	61	4	45	92	50	97	147	120	64	20	60	102	6.5	12	M10x1.25
40	16	15	87	M6	6.6	11	38	84	69	18	55	112	58	116	167	125	81	25	63	127	6	12	M12x1.25
50	20	19	104	M8	9	15	47	100	85	24	68	134	70	137	195	140	94	25	70	134	9	16	M16x1.5
63	20	19	119	M8	9	15	57	105	100	20	80	148	85	152	195	160	94	25	75	145	9	16	M16x1.5
80	25	22	148	M10	11	18	72	130	130	25	100	180	105	189	241	195	114	30	89	157	11	20	M20x1.5
100	25	22	173	M10	11	18	89	150	150	30	120	206	130	213	241	205	120	30	90	172	11	20	M20x1.5

Dimensions Stroke Adjusting Unit

[mm]

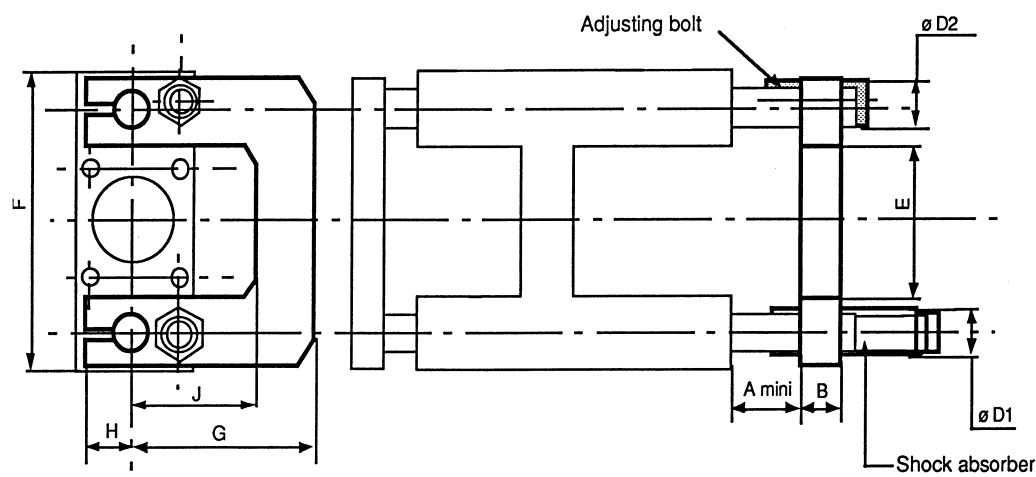

A minimum length will have to be added on for stroke adjusting unit.

(mm)

Diameter	Model	A	B	D1	D2	E	F	G	H	J	Min. add on stroke
ø32	SFY(F)133	35.5	15	M14x1.5	M8	51	95	78	17	53	51
ø40	SFY(F)134	45	20	M20x1.5	M10	59	114	87	25	62	65
ø50	SFY(F)135	45	25	M20x1.5	M10	72	135	98	28	68	70
ø63	SFY(F)136	45	25	M25x1.5	M10	86	150	118	28	88	70

Series CP95

Permissible Rotary Torque Plate (Nm)

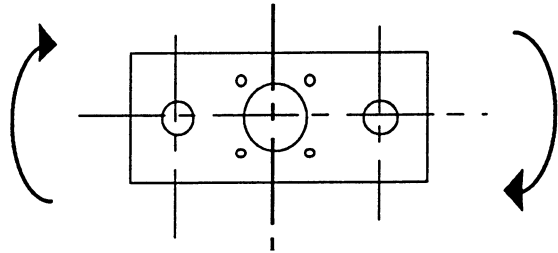

Diameter (mm)	Series	Stroke					
		50	100	200	300	400	500
32	GUM	11.4	7.5	4.0	2.7	2.2	-
32	GUL	6.0	4.5	3.1	2.3	1.8	-
40	GUM	21.7	16.6	9.9	7.0	5.1	3.6
40	GUL	11.1	8.4	5.7	4.35	3.48	2.9
50	GUM	37.4	28.7	15.3	11.5	9.1	6.7
50	GUL	18.5	14.5	10.0	7.6	5.9	4.7
63	GUM	47.6	36.1	20.1	13.9	10.7	8.0
63	GUL	22.6	17.9	12.7	9.8	8.0	6.4
80	GUM	81.4	65.1	42.1	28.8	21.8	17.3
80	GUL	45.5	37.2	27.3	21.6	17.8	15.1
100	GUM	95.1	76.1	49.3	33.7	25.5	20.3
100	GUL	53.1	43.5	32.0	25.2	20.8	17.7

Allowable Load [daN]

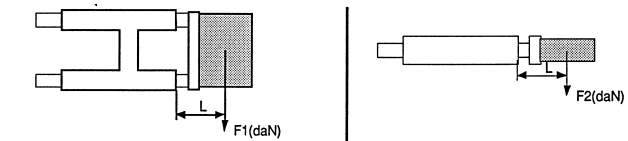

Dynamic load $F_1 = \text{See Graphs}$
 Static load $F_3 = F_1 \times 2$

Dynamic load $F_2 = F_1 \times 0.9$
 Static load $F_4 = F_2 \times 2$

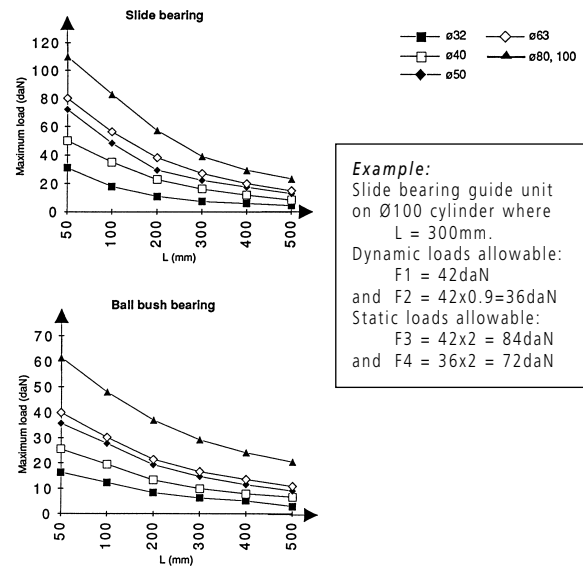

Deflection (For max. allowable load)

[mm]

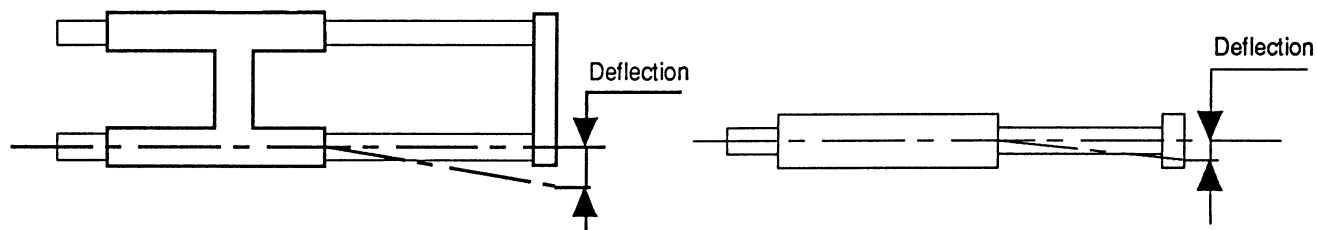

Diameter (mm)	Series	Stroke					
		50	100	200	300	400	500
32	GUM	0.09	0.32	1.06	2.10	3.90	-
32	GUL	0.05	0.20	0.80	1.80	3.30	-
40	GUM	0.05	0.19	0.70	1.50	2.40	3.30
40	GUL	0.02	0.10	0.40	0.90	1.60	2.60
50	GUM	0.03	0.12	0.38	0.90	1.50	2.10
50	GUL	0.015	0.06	0.25	0.57	1.00	1.50
63	GUM	0.04	0.15	0.47	0.96	1.60	2.30
63	GUL	0.018	0.07	0.30	0.70	1.20	1.80
80	GUM	0.03	0.10	0.36	0.70	1.15	1.69
80	GUL	0.015	0.06	0.24	0.54	0.95	1.50
100	GUM	0.03	0.10	0.36	0.70	1.15	1.69
100	GUL	0.015	0.06	0.24	0.54	0.95	1.50

The values are for maximum allowable load and are the same for both mounting examples shown.

Series CP95

Cylinder Flow Rate and Air Consumption

In order to determine the correct size of valves, piping and accessories the maximum air consumption should be calculated. Air consumption is determined by the total maximum air consumed by all the cylinders that operate during an operating cycle, and is dependant on the maximum cylinder speed.

Theoretical maximum air consumption

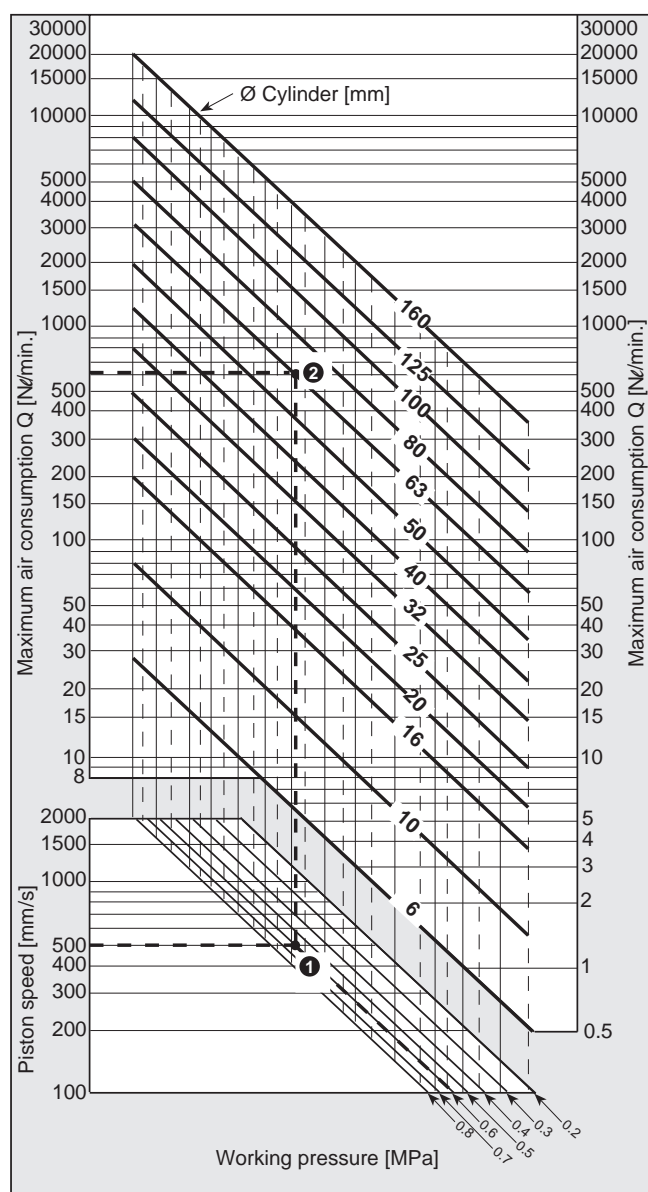

Thermal loss is not represented in this diagram. For this reason, the air consumption is multiplied by 1.4. This factor is an average value.

Example

Calculate the maximum effective air consumption of a Ø63 cylinder at an average speed of 500 mm/s. The working pressure is 0.6 MPa.

Solution

1. Determine the intersection point ❶ of the 0.6 MPa working pressure on the horizontal axis with the 500 mm/s average speed on the vertical axis.
2. Extend the intersection point ❶ upward to the Ø63 cylinder. Intersection point ❷ is obtained.
3. Extend the intersection point ❷ rightward or leftward. A Q value of approximately 620 Nl/min is obtained.
4. The 620 Nl/min. theoretical value is multiplied by 1.4
 $Q = 620 \text{ Nl/min.} \times 1.4$
 $Q = 870 \text{ Nl/min.}$

Series CP95

Average air consumption of compressed air cylinders and piping

In order to find the appropriate size of the compressor and the compressed air supply. It is necessary to determine the average compressed air consumption.

Average theoretical air consumption of cylinders in a cycle/m. (1 cycle = SWITCH ON/SWITCH OFF)

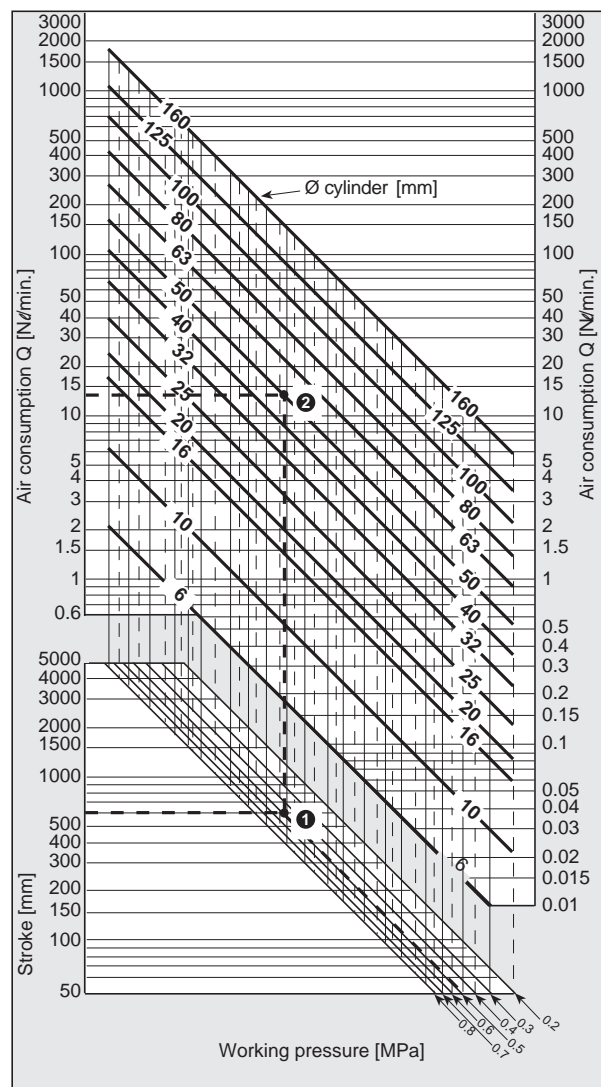

Example:

Cylinder diameter: Ø50 mm
 Stroke: 600 mm
 Working pressure: 0.5 MPa
 Cycles: 5 per minute
 Bore size: 6 mm
 Piping length (between the cylinder and the valve): 2 m

Cylinder air consumption

- Determine the intersection point ① of a 0.5 MPa working pressure with a stroke of 600 mm.
- Extend the intersection point ① upward to the intersection point 2 where a Ø50 mm is represented.
- Extend the intersection point ② rightward or leftward. The Q value of 13.5 Nl/min. is obtained.
- The value of 13.5 Nl/min. is multiplied by 1.4 and by the number of cycles.
 $Q_1 = 13.5 \text{ Nl/min.} \times 1.4 \times 5 \text{ cycles} = 94.5 \text{ Nl/min.}$

Thermal loss is not represented in this diagram. For this reason, the air consumption is multiplied by 1.4. This factor is an average value.

Theoretical air consumption of compressed air piping

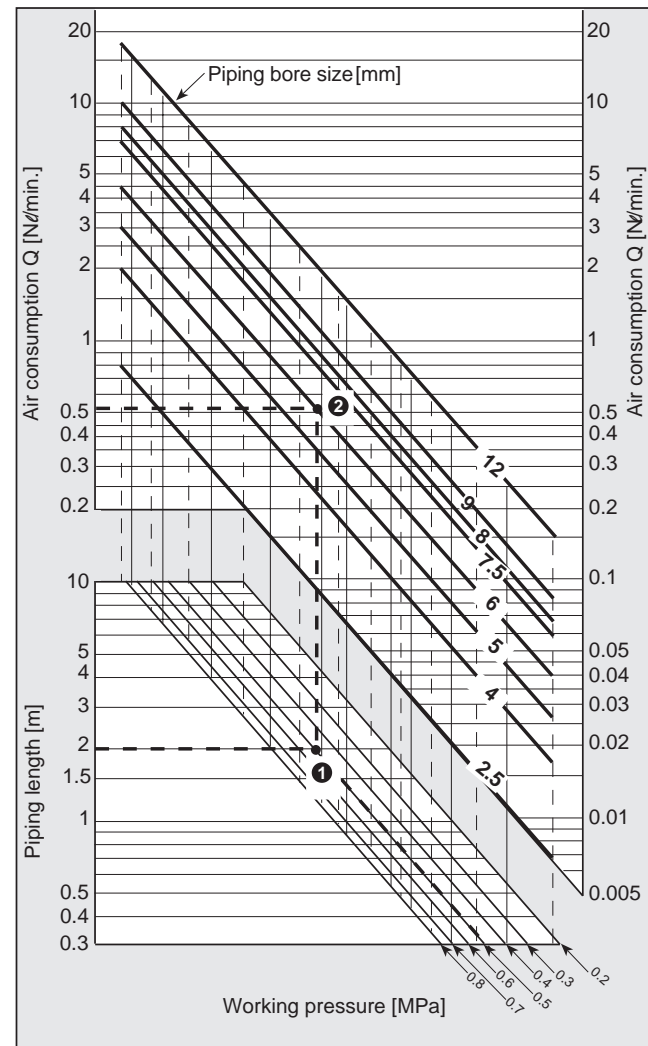

Air consumption of compressed air piping

- Determine the intersection point ① of a 0.5 MPa working pressure with a piping length of 2m.
- Extend the intersection point ① upward to a Ø6 piping bore size. Intersection point ② is obtained.
- Extend the intersection point ② rightward or leftward. Value: $Q = 0.56 \text{ Nl/min.}$
- The value of 0.56 Nl/min. is multiplied by 1.4 and by the number of cycles.
 $Q_2 = 0.56 \text{ Nl/min.} \times 1.4 \times 5 \text{ cycles} = 3.92 \text{ Nl/min.}$

Total air consumption of compressed air cylinder and piping:





$$Q = Q_1 + Q_2 = 94.5 \text{ Nl/min.} + 4 \text{ Nl/min.} = 98.5 \text{ Nl/min.}$$

Series CP95

Maximum stroke determination

The table below indicates the maximum stroke with different mounting accessories. The values are for standard applications when a cylinder drives a load (m) that corresponds to the cylinder theoretical output which results from a determined working pressure. If the rod diameter is not the appropriate one in relation to the pressure and the stroke, a longer stroke cylinder should be selected or pressure should be reduced.

Allowable theoretical strokes (mm)

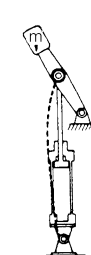
	Mounting type			Accessories	Pressure [MPa]	Bore (mm)					
	L	F (front)	G (rear)			32	40	50	63	80	100b
				L • F (front)	0.2	680	–	–	980	1220	1410
					0.3	540	–	1020	790	980	1140
					0.4	460	700	880	680	840	980
					0.5	410	630	780	610	750	880
					0.6	370	580	710	550	680	800
					0.7	340	520	650	500	620	730
					0.8	310	480	600	460	580	680
					0.9	290	450	570	430	540	630
					1	270	420	530	400	510	590
				G (rear)	0.2	580	450	580	430	540	630
					0.3	450	350	460	340	420	500
					0.4	370	300	390	280	350	420
					0.5	310	260	340	250	310	370
					0.6	270	230	300	220	270	330
					0.7	240	210	270	190	240	290
					0.8	210	190	250	170	220	270
					0.9	190	170	230	160	200	240
					1	170	160	210	140	190	220
						C•D			C • D	0.2	–
0.3	–	760	960	730						910	1050
0.4	–	640	820	620						770	890
0.5	–	570	720	540						680	780
0.6	630	510	650	490						610	700
0.7	560	460	600	440						550	640
0.8	510	430	550	400						510	580
0.9	470	400	510	380						470	550
1	430	370	480	350						440	510

- G – Rear flange
- F – Front flange
- L – Foot
- C – Male rear clevis
- D – Female rear clevis

Maximum stroke determination

Allowable theoretical strokes (mm)

	Mounting type			Accessories	Pressure [MPa]	Bore (mm)							
	L	F (front)	G (rear)			32	40	50	63	80	100		
				L • F (front)	0.2								
					0.3								
					0.4								
					0.5								
					0.6								
					0.7								
					0.8								
					0.9								
					1	*)	*)	*)	*)	*)	*)	*)	
				G (rear)	0.2								
					0.3								
					0.4						1160	1360	
					0.5						940	1160	1350
					0.6						1080	830	1020
					0.7						770	980	750
					0.8						700	900	680
					0.9						650	830	630
1	*)	*)	*)	*)	*)	610	790	590					
1	*)	*)	*)	*)	*)	580	740	560					
				L • F (front)	0.2								
					0.3								
					0.4								
					0.5								
					0.6								
					0.7								
					0.8								
					0.9								
					1	*)	*)	*)	*)	*)	*)	*)	
				G (rear)	0.2								
					0.3								
					0.4								
					0.5								
					0.6							1010	1380
					0.7							1020	1270
					0.8							950	1180
					0.9							1160	890
1	*)	*)	*)	*)	*)	1090	840	1040					
1	*)	*)	*)	*)	*)	1090	840	1040					

*) The maximum standard stroke should be used depending on the cylinder diameter (Refer to page 11 below for standard strokes).

- G – Rear flange
- F – Front flange
- L – Foot
- C – Male rear clevis
- D – Female rear clevis





Series CP95

Safety Instructions

These safety instructions are intended to prevent a hazardous situation and/or equipment damage. These instructions indicate the level of potential hazard by a label of "**Caution**", "**Warning**" or "**Danger**". To ensure safety, be sure to observe ISO 4414 Note 1), JIS B 8370 Note 2) and other safety practices.

 **Caution** : Operator error could result in injury or equipment damage.

 **Warning** : Operator error could result in serious injury or loss of life.

 **Danger** : In extreme conditions, there is a possible result of serious injury or loss of life.

Note 1) ISO 4414 : Pneumatic fluid power – Recommendations for the application of equipment to transmission and control systems.

Note 2) JIS B 8370 : Pneumatic system axiom.

Warning

1 The compatibility of pneumatic equipment is the responsibility of the person who designs the pneumatic system or decides its specifications.

Since the products specified here are used in various operating conditions, their compatibility for the specific pneumatic system must be based on specifications or after analysis and/or tests to meet your specific requirements.

2 Only trained personnel should operate pneumatically operated machinery and equipment.

Compressed air can be dangerous if an operator is unfamiliar with it. Assembly, handling or repair of pneumatic systems should be performed by trained and experienced operators.

3 Do not service machinery/equipment or attempt to remove components until safety is confirmed.

1. Inspection and maintenance of machinery/equipment should only be performed after confirmation of safe locked-out control positions.
2. When equipment is to be removed, confirm the safety process as mentioned above. Cut the supply pressure for this equipment and exhaust all residual compressed air in the system.
3. Before machinery/equipment is re-started, take measures to prevent shooting-out of cylinder piston rod, etc. (Bleed air into the system gradually to create back-pressure.)

4 Contact SMC if the product is to be used in any of the following conditions:

1. Conditions and environments beyond the given specifications, or if product is used outdoors.
2. Installation on equipment in conjunction with atomic energy, railway, air navigation, vehicles, medical equipment, food and beverages, recreation equipment, emergency stop circuits, press applications, or safety equipment.
3. An application which has the possibility of having negative effects on people, property, or animals, requiring special safety analysis.



Series CP95 Cylinder precautions

Be sure to read before handling.

Precautions on design

⚠ Warning

1. When mounting a cylinder in vertical position, the rod may come out due to an abnormal pressure drop.
2. A protective cover is recommended to minimize the risk of personal injury.
3. Securely tighten all stationary parts and connected parts so that they will not become loose.
4. Consider a possible drop in operating pressure due to a power outage, etc.
5. Design the system circuitry in order to prevent sudden lurching of driven objects.
6. Consider emergency stops.
7. Consider the action when operation is restarted after an emergency stop or abnormal stop. Design the machinery so that human injury or equipment damage will not occur upon restart of operation.

Selection

⚠ Caution

1. Check the catalogue specifications.
2. Use a speed controller to adjust the cylinder drive speed, gradually increasing from a low speed to the desired speed setting.

Security precautions

1. Strokes must not exceed the specified limits.
2. Higher speed than specified may cause malfunction to the end of stroke cushioning.
3. When operating with long strokes, an intermediate band should be used to stabilize the rod (danger of bending).

Piston maximum speed

When an auto switch is placed at an intermediate position of the stroke and the piston speed is too high, the operating time will be shortened and the load may not operate properly. The maximum detectable piston speed is:

$$V = \frac{\text{Auto switch operating range [mm]}}{\text{Time load applied [s]}} \times 100$$

Example:

The operating range of a D-A73L Reed switch mounted in a CP95 cylinder is 8 mm. The operating time required to operate an electric valve is 30 ms = 0.003 s.

$$\text{Maximum piston speed } V = \frac{8 \text{ mm}}{0.003 \text{ s}} = 266 \text{ mm/s}$$

Mounting

⚠ Warning

1. Make sure that there are no variations in the alignment between the rod centre and the load centre.
2. If a guide is required, make sure transverse forces do not occur.
3. Avoid scratches on the rod.
4. Do not use until you verify that the equipment can operate properly.
5. The product should be mounted and operated after thoroughly reading the manual and understanding its contents.
6. Remove the packing of the air components, only at the moment of its mounting.

Wiring

⚠ Caution

1. Be sure that piping diameters are bigger than the connection thread diameters.
2. Before piping is connected, it should be thoroughly blown out with air (flushing) or washed to remove dust or other debris from inside the pipe.
3. Be certain that sealing material does not get inside the piping.
4. When pipe tape is used, leave 1.5 to 2 thread ridges exposed at the end of the pipe fitting.

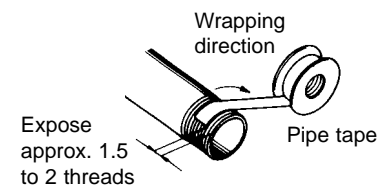

Lubrication

⚠ Caution

1. The cylinders have been lubricated for life at the factory and can be used without any further lubrication.

Air supply

⚠ Warning

1. Use clean air.
2. Install air filters.
3. Install a water separator after the cooler.
4. Use the product within the specified range of fluid and ambient temperature.

(continued overleaf...)

Series CP95

Cylinder precautions continued

Operating Environment

⚠ Warning

1. Do not operate in environments with corrosive gases, sea water, water or steam.
2. In locations where there is contact with spatter from water or oil, implement suitable protective measures.
3. If the cylinders are equipped with auto switches, do not operate in locations where there are strong magnetic fields.

End of stroke cushioning

⚠ Caution

1. Set screw adjusting.
The set screw has been already adjusted at the factory. Once it has been used, the set screw must be readjusted. Take into account the operating environment as well as the load size and weight. The effectivity of the end of stroke cushioning is shortened by the clockwise screw turn. The set screw should be secured by a locking washer.
2. Do not operate the cylinder when the set screw has been completely tightened.

Cylinder mounting

⚠ Warning

1. The maximum tightening torque must not exceed the specified diameter limits, because it may reduce the non-rotating guide accuracy.
2. When mounting rod accessories, be sure that moment does not occur to the ball joint piston rod in the cylinder headcover. Do not use an adjustable angle wrench on the operating surface of the rod.

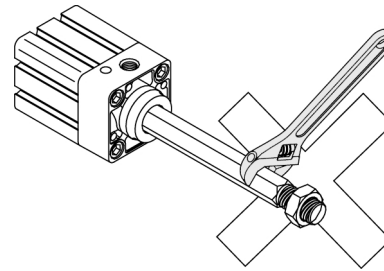



Series CP95 Auto Switch Precautions

Be sure to read before handling.

Auto Switch Precautions

Caution

1. Confirm the specifications.
2. When multiple auto switch cylinders are used in close proximity, magnetic field interference may cause the switches to malfunction. Maintain a minimum cylinder separation of 40 mm.
3. Wiring should be kept as short as possible.
4. Do not touch the piston rod when operating the cylinder.
5. Avoid close contact with magnetic substances (something attracted by a magnet), as the piston has a magnet ring which detects the magnetic force.
6. Lead wire colours of Reed and Solid state switches have been changed. These changes have been validated for production beginning September 1997.

2 wire

	Old	New
Output (+)	Red	Brown
Output (-)	Black	Blue

3 wire

	Old	New
Power supply(+)	Red	Brown
GND (-)	Black	Blue
Output	White	Black

Auto switch wiring

1. Load must not exceed the specified current and voltage limits.
2. Be sure to connect the load before power is applied.
3. Switches with indicator light have polarity. The brown lead wire is (+), and the blue lead wire is (-). If connections are reversed, a switch will operate, however, the light emitting diode will not light up.
4. When a switch with an indicator light operates under the specified current, even though the switch operates normally, the indicator light may hardly light up or may not light up.
5. A voltage drop affects every auto switch when connected in series because of internal resistance in the light emitting diode.
6. When operating under a specified voltage, the internal voltage drop in the indicator light may cause the load malfunction.
7. If the internal voltage drop causes a problem, select a switch with no indicator light.

Auto Switch mounting

1. Although Reed switches have a 30G impact resistance, avoid bumps or excessive impacts.
2. Do not use in an area where magnetic fields are generated in order to avoid switches malfunction.
3. Avoid repeatedly bending or stretching lead wires.
4. Although switches satisfy the IEC standard IP67 structure (JIS C 0920: anti-immersion structure), do not use switches in applications where continually exposed to water, oil, coolant liquid, etc.

Wiring

Warning

1. Confirm proper insulation of wiring.
2. Do not wire with high voltage lines.
3. Avoid incorrect wiring.

Operating environment

Warning

1. Never use in an atmosphere of explosive gases.
2. Do not use in an area where magnetic fields are generated.
3. Do not use in an environment where the auto switch will be continually exposed to water.
4. Do not use in an environment with oil or chemicals.
5. Consult SMC if switches are used where there are temperature cycles other than normal temperature changes.
6. Do not use in locations where excessive impacts are generated. If an impact of 30G or more is applied to a switch, the signal may be interrupted for 1ms or less. Consult SMC the need of using a solid state switch depending on the environment.
7. Avoid accumulation of iron powder or close contact with magnetic substances.

(continued overleaf...)

Series CP95

Auto Switch precautions continued

Reed switch precautions

Caution

Noncontact switches are generally used in applications where other switches which are operated mechanically do not provide an optimal functioning in adverse environmental conditions, such as high frequency, dusty, dirty or very humid conditions.

Specifications

Reed switches have a Reed contact. There are two fine ferronickel-alloy contacts in a glass body. The force applied to close the contacts is minimal due to the short distance between them. Reed switches do not have protection circuits. For this reason, they should be provided with an external contact protection box.

1. The operating load is an inductive load
2. The length of wiring to the load is > 5 m
3. The load voltage is > 100 V AC

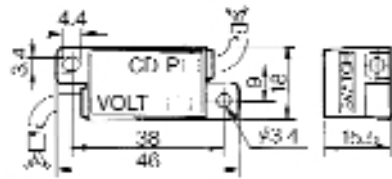

Contact protection box specifications

Part No.	CD-P11	CD-P12
Load voltage	110V AC	220 V AC
Max. load current	23 mA	11.5 mA

Lead wire length: Switch connection side 0.5 m
Load connection side 0.5 m

Contact protection box / Internal circuits

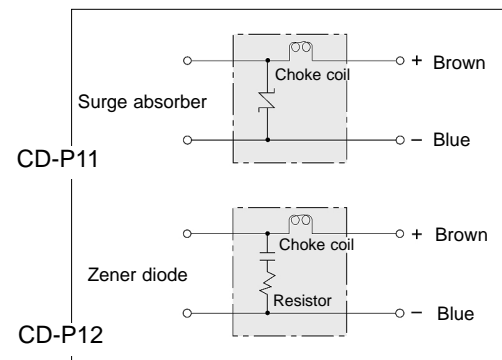

Contact protection box / Connection

To connect a switch unit to a contact protection box, connect the lead wire from the side of the contact protection box marked SWITCH to the lead wire coming out of the switch unit. The length of lead wire should be as short as possible, with a maximum of 1 m.

Main Index Series CP95

	Page No.
Key Features	2-3
Available Specifications	4
How to Order	
Cylinders	4
Mounting Accessories	5
Switches	19-22
Switch Holder	22
Switch Groove Cover	22
Seal Kits	
Standard Model	8
Non-rotating Model	14
Technical Specification	
Standard Model	6
Non-rotating Model	13
Theoretical Output Table	
Standard Model	7
Non-rotating Model	14
Kinetic Energy Absorption	7
Moveable Mass	7
Cylinder Weight	7
Cylinder Construction	8
Moveable Mass	8
Allowable Loads	8
Cylinder Dimension	
Standard Model	9
Non-rotating Model	15
Accessory Dimensions	
Standard Model	10 – 12
Non-rotating model	16 – 17
Piston Rod Accessories	18
Auto Switch Specifications	19 – 21
Auto Switch Mounting	22
Auto Switch Holders	22
Groove Covers	22
Guide Units	
How To Order	24
Dimensions	24
Stroke Adjusting Unit (for guide unit)	
How To Order	23
Dimensions	24
Shock Absorber (for guide unit)	
How To Order	23
Air Consumption	
Cylinder (max.)	26
Cylinder and Piping	27
Max. Stroke Determination	
Theoretical	28 – 29
Safety Instructions	
Cylinder	30 – 32
Auto Switches	33 – 34

